

**CITY OF CUPERTINO
STANDARD DETAILS**

**CUPERTINO CITY HALL
10300 TORRE AVENUE
CUPERTINO, CA 95014**

(408) 777-3200



**Department of Public Works
Ralph A. Qualls, Jr.
Director of Public Works**

TABLE OF CONTENTS

	<u>PAGE</u>
<u>GENERAL</u>	
GENERAL NOTES	
DRAFTING STANDARDS	0 - 7
1. <u>STREETS</u>	
RESIDENTIAL STREET SECTIONS (CUL-DE-SACS)	1 - 1
RESIDENTIAL STREET SECTIONS	1 - 2
STANDARD STREET SECTIONS	1 - 4
STANDARD STREET SECTIONS	1 - 6
STANDARD STREET SECTIONS	1 - 8
SPECIAL HILLSIDE SECTIONS	1 - 10
RURAL AND SEMI-RURAL STREET SECTIONS	1 - 11
CUL-DE-SACS	1 - 12
STREET MONUMENT	1 - 14
CURB SECTION	1 - 16
VALLEY GUTTER	1 - 18
SIDEWALK DETAIL	1 - 19
DRIVEWAY – DETACHED SIDEWALK	1 - 20
DRIVEWAY – MONOLITHIC SIDEWALK	1 - 21
DRIVEWAY – MONOLITHIC SIDEWALK OPTION 2	1 - 21B
SIDEWALK CORNER TRANSITION	1 - 22
DOWEL CONNECTIONS	1 - 23
CURB RAMP DETAILS	1 - 24
CURB RAMP DETAIL	1 - 26
SIDEWALK TRANSITION	1 - 28
SIDEWALK TRANSITION AROUND EXISTING STREET	1 - 30
CIRCULAR DRIVEWAY DETAIL	1 - 32

TABLE OF CONTENTS

PAGE 2

	<u>PAGE</u>
2. <u>SIGNS, STRIPING, CHANNELIZATION</u>	
STREET BARRICADE	2 - 2
OBJECT MARKING DETAIL	2 - 3
ACCESS CONTROL ISLANDS	2 - 16
THROUGH MOVEMENT CONTROL ISLANDS	2 - 18
SIGN POSTS	2 - 20
STREET NAME SIGNS ON TRAFFIC SIGNAL POLES	2 - 21
STREET NAME SIGN MOUNTING ON SIGN POLE	2 - 22
PUBLIC SERVICE BANNER	2 - 24
LANE LINE MARKERS	2 - 26
BIKE LANE DETAILS	2 - 27
PARKING AND AISLES – ONE WAY	2 - 28
PARKING AND AISLES – TWO WAY	2 - 30
PARKING AND AISLES - INDUSTRIAL & DISABLED	2 – 32
3. <u>STORM</u>	
DROP INLET - CURB OPENING	3 - 2
24” FLAT GRATE DROP INLET	3 - 4
FIELD INLET – SIDE OPENING	3 – 8
CONCENTRIC MANHOLE	3 - 10
ECCENTRIC MANHOLE - 8” - 33” PIPE	3 - 12
ECCENTRIC MANHOLE - 36” - 48” PIPE	3 - 14
ECCENTRIC MANHOLE - 51” PIPE AND LARGER	3 - 16
STANDARD CONNECTION TO MANHOLE WALL	3 - 18
STANDARD CONNECTION TO RCP - 48” & LARGER	3 - 20

TABLE OF CONTENTS

PAGE 3

	<u>PAGE</u>
4. <u>TRENCHES</u>	
TRENCH BACKFILL REQUIREMENTS	4 – 24
MICROTRENCHING – DETAIL AND SPECIFICATIONS	4 – 25
5. <u>ELECTROLIERS & ELECTRICAL</u>	
ELECTROLIER & CONDUIT LOCATION W/SIDEWALK	5 - 2
ELECTROLIER & CONDUIT LOCATION W/O SIDEWALK	5 - 4
ELECTROLIER & CONDUIT LOCATION IN MEDIANS	5 - 6
35 FT. ELECTROLIER STANDARD	5 - 8
30 FT. ELECTROLIER STANDARD	5 - 10
ELECTROLIER FOUNDATION	5 - 12
TRADITIONAL FOUNDATION – MONTA VISTA	5 - 14
CONDUIT INSTALLATION FOR LOOP DETECTOR	5 - 16
TYPE ‘SA’ LOOP INSTALLATION	5 - 17
SPECIAL LOOP INSTALLATION	5 - 18
TYPE QC/CIRCULAR LOOP INSTALLATION	5 - 19
SERVICE DETAIL	5 - 20
LIGHTING NOTES	5 - 22
6. <u>TREE PLANTING PUBLIC RIGHT-OF WAY</u>	
TREE PROTECTION NOTES	6 - 2
TREE TRUNK PROTECTION	6 - 3
TREE FENCING PROTECTION	6 - 4
TREE PLANTING IN PUBLIC RIGHT OF WAY	6 - 6
TREE PLANTING IN PUBLIC RIGHT OF WAY	6 - 8
TREE PLANTING W/ BUBBLE INSTALLATION	6 - 10

TABLE OF CONTENTS

PAGE 4

	<u>PAGE</u>
7. <u>SIGHT TRIANGLES</u>	
CONTROLLED INTERSECTION	7 - 2
UNCONTROLLED INTERSECTION	7 - 4
SIDEWALK CLEARANCE @ DRIVEWAY	7 - 6
8. <u>SPECIAL</u>	
CONCRETE BLOCK RETAINING WALL	8 - 2
TIMBER RETAINING WALL	8 - 4
CLOSING OF BLOCK	8 - 6
TRAFFIC SIGNAL PHASING	8 - 8
TURF BLOCK	8 - 14
GRASSED WATERWAYS WITH JUTE MAT	8 - 16
STRAW ROLLS	8 - 18

CITY OF CUPERTINO DRAFTING STANDARDS

	EXISTING	PROPOSED	DESCRIPTION
1	DASHED LINE	SOLID LINES	
2	8" V.C.P.	8" V.C.P.	SANITARY SEWER AND FLUSHING INLET
3	8" V.C.P.	8" V.C.P.	SANITARY SEWER AND MANHOLE
4	12" R.C.P.	12" R.C.P.	STORM SEWER AND MANHOLE
5	(SPECIFY SIZE AND STYLE)	(SPECIFY SIZE AND STYLE)	STORM DROP INLET AND LATERAL
6	(SPECIFY SIZE AND STYLE)	(SPECIFY SIZE AND STYLE)	WATER MAIN
7	FIRE HYDRANT	FIRE HYDRANT	FIRE HYDRANT
8	GATE VALVE	GATE VALVE	GATE VALVE
9	BLOW - OFF	BLOW - OFF	BLOW - OFF
10	TEE (WATER)	TEE (WATER)	TEE (WATER)
11	CROSS (WATER)	CROSS (WATER)	CROSS (WATER)
12	REDUCER	REDUCER	REDUCER
13	MONUMENT	MONUMENT	MONUMENT
14	CURB & GUTTER	CURB & GUTTER	CURB & GUTTER
15	ELECTROLIER WITH CONDUIT	ELECTROLIER WITH CONDUIT	ELECTROLIER WITH CONDUIT
16	GAS LINES - INDICATE SIZE	GAS LINES - INDICATE SIZE	GAS LINES - INDICATE SIZE
17	TELEPHONE DUCT (CONDUIT) INDICATE SIZE	TELEPHONE DUCT (CONDUIT) INDICATE SIZE	TELEPHONE DUCT (CONDUIT) INDICATE SIZE
18	STREET NAME SIGN	STREET NAME SIGN	STREET NAME SIGN
19	TRAFFIC SIGNS	TRAFFIC SIGNS	TRAFFIC SIGNS
20	EXISTING EDGE OF PAVEMENT	EXISTING EDGE OF PAVEMENT	EXISTING EDGE OF PAVEMENT

CITY OF CUPERTINO GENERAL NOTES

1. All work shall be in accordance with the State of California Department of Transportation Standard Specifications (latest edition, as amended), and Standard Plans (latest edition, as amended), and City of Cupertino Standard Details. The Contractor shall perform the work described in the specification, and as shown on the drawings, and to the satisfaction of the City Engineer.
2. Approval of these plans shall not release the Owner or Contractor of the responsibility for corrections of mistakes, errors, or omissions contained therein. If during the course of construction of improvements, public interest requires a modification of/or a departure from the City of Cupertino Standard Details or these improvements plans, the City Engineer shall have the authority to require such modification or departure and to specify the manner in which the same is to be completed, at the sole expense of the Owner or Contractor.
3. Approval of these plans by the City Engineer is only for public right-of-way improvements (including storm drain in the right of way), and not for water, sewer or dry utilities. It is the Developer's/Owner's responsibility to coordinate reviews and approval from each of the Utility companies, and to provide approval letters as requested.
4. It shall be the responsibility of the Contractor to ensure the approved plans or the latest revised plans are furnished to its subcontractors, and to ensure the latest approved plans are onsite at all times during construction.
5. The Contractor shall notify the City of Cupertino Public Works Inspector two (2) working days prior to requiring an inspection. Call (408) 777-3104 to schedule Public Works inspections.
6. Construction area traffic control devices shall be installed prior to beginning of work.
7. Notify City of Cupertino Traffic Signal Maintenance for inspection of traffic signal facility foundation excavations at (408) 777-1366, two (2) working days prior to pouring any cabinet or signal foundations relating to the job.
8. The Contractor shall locate underground facilities in the area of work. The Contractor shall contact Underground Service Alert (USA) at 811 two (2) working days in advance of any work for location of the underground facilities.
9. All underground utilities shall be installed and backfilled before placement of the base material and surface structures. If utilities are to be installed subsequently, a written notification from the affected utility company indicating its commitment to bore or tunnel shall be submitted to the City Engineer before proceeding with the work. Underground utilities, except storm drains and sanitary sewers, shall not be permitted in pavement area, with the exception of street crossings, unless approved by the City Engineer.

CITY OF CUPERTINO
STANDARD DETAILS

APPROVED BY: _____

CITY ENGINEER

DATE: 6/29/16

10. All water lines, valves, hydrants, and appurtenances thereto installed within the public right-of-way shall be the property of the water utility company.
11. Storm drain lines installed as part of the work on these plans shall be cleared of all debris and obstructions prior to final acceptance.
12. All trench backfill, fill areas, and base material shall attain a minimum 95% relative compaction. For typical trench sections, except for sanitary sewers, refer to the City Standard Details.
13. The Developer shall pay all costs for moisture-density curves (Calif. Test No. 216E) and any other tests required by the City Engineer during street construction.
14. Trees, roots, and foreign matter in existing or proposed right-of-way shall be removed to a depth of two (2) feet below subgrade and disposed of per Caltrans Standards. In the case of live tree roots from City street trees, Contractor shall contact the City for field observation prior to removing tree roots.
15. Trench plates in the traveled way shall be traffic rated, property secured and shall be recessed upon the request of the Director of Public Works.
16. All trenches located within 5' of the edge of pavement (ie. curb, lip of gutter, edge of pavement, etc.) shall be repaved to the edge of pavement.
17. All new pavement shall match the existing pavement section. A minimum pavement section of 3" AC/6" Class 2 AB is required.
18. Existing pavement that is removed or damaged shall be replaced as required by the City Engineer.
19. Manhole frames and covers shall be brought to finish grade prior to final signoff.
20. Five (5) working days prior to installing permanent striping, the Contractor shall cat track the striping and request review of the cat tracks by the City Traffic Engineer. The City Engineer shall have the right to make changes in the location of the alignment of traffic stripes, pavement markings, and pavement markers.
21. Concrete for use in all concrete structures shall conform to California Department of Transportation Standard Specifications Section 90. Drop inlets, sidewalks, curbs and gutters shall contain 590 lbs. of cement per cubic yard and shall attain a minimum strength of 3,000 psi in 28 days.
22. Drop inlets shall be constructed conforming to City Standard Details unless otherwise noted on the plans. If grate openings align with direction of path of travel, openings shall be no wider than 1/2". Drop Inlets shall be installed concurrent with the construction of the curb and gutter. "No Dumping Flows to the Bay" plaque shall be installed on the curb adjacent to all inlets.

CITY OF CUPERTINO
STANDARD DETAILS

APPROVED BY:

CITY ENGINEER

DATE: 6/29/16

23. A minimum thickness of five (6) inches of concrete shall be required for commercial driveway approaches and four (5) inches for residential. The driveway approach shall be installed concurrent with the construction of the curb and gutter.
24. One pound of dispersing black shall be mixed with each cubic yard of concrete at the batch plant.
25. City Standard Street Lights shall be installed as required by the Director of Public Works, and shall conform to the City Standard Details and Notes. During construction operations, temporary street lighting shall be provided as necessary to ensure the public safety. Temporary street lights shall be installed at the discretion of, and to the satisfaction of, the Director of Public Works.
26. City standard street monuments shall be constructed at the locations shown on the plans or as directed by the City Engineer.
27. New City standard street monuments and other permanent monuments disturbed during construction shall be replaced before acceptance of the improvements by the City Engineer. Attention is directed to Section 8771 of the California Business and Professions Code for the requirements concerning survey monuments. Existing survey monuments shall be located and referenced by or under the direction of a licensed land surveyor or registered civil engineer prior to construction operations, and a corner record or record of survey shall be filed with the County Surveyor of the County of Santa Clara. Existing survey monuments shall be reset to finish grade, and a corner record or record of survey shall be filed with the County Surveyor of the County of Santa Clara prior to the recording of the certificate of completion for the project.
28. Construction survey stakes or marks (control stakes) to establish lines and grades shall be set by the Contractor's surveyor or engineer.
29. Notify the City Inspector two (2) working days in advance of requiring services for checking field staking. Three (3) copies of the cut sheets shall be furnished to the City Inspector.
30. Grading of lots shall be completed as determined by the City Engineer, as shown on the plans, and shall follow requirements and standards as set forth in the City Standard Grading and Drainage notes.
31. Demolition of septic tanks shall conform to Santa Clara County Environmental Health Department regulations. Work shall be done prior to construction.

CITY OF CUPERTINO
STANDARD DETAILS

APPROVED BY:

CITY ENGINEER

DATE:

6/29/16

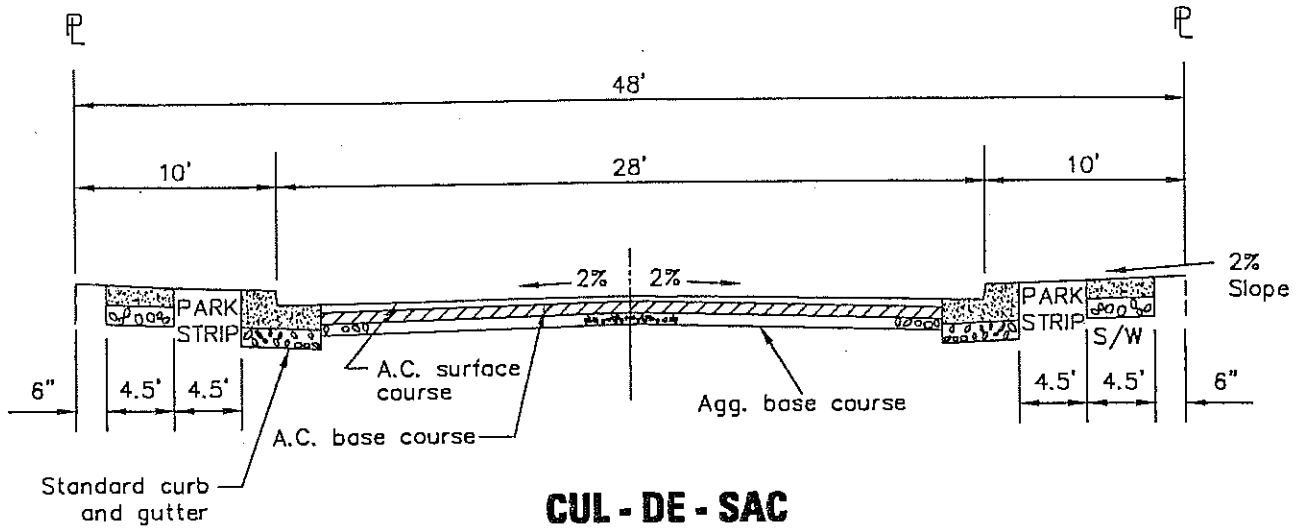

CUL - DE - SAC

(PARKING ON ONE SIDE)

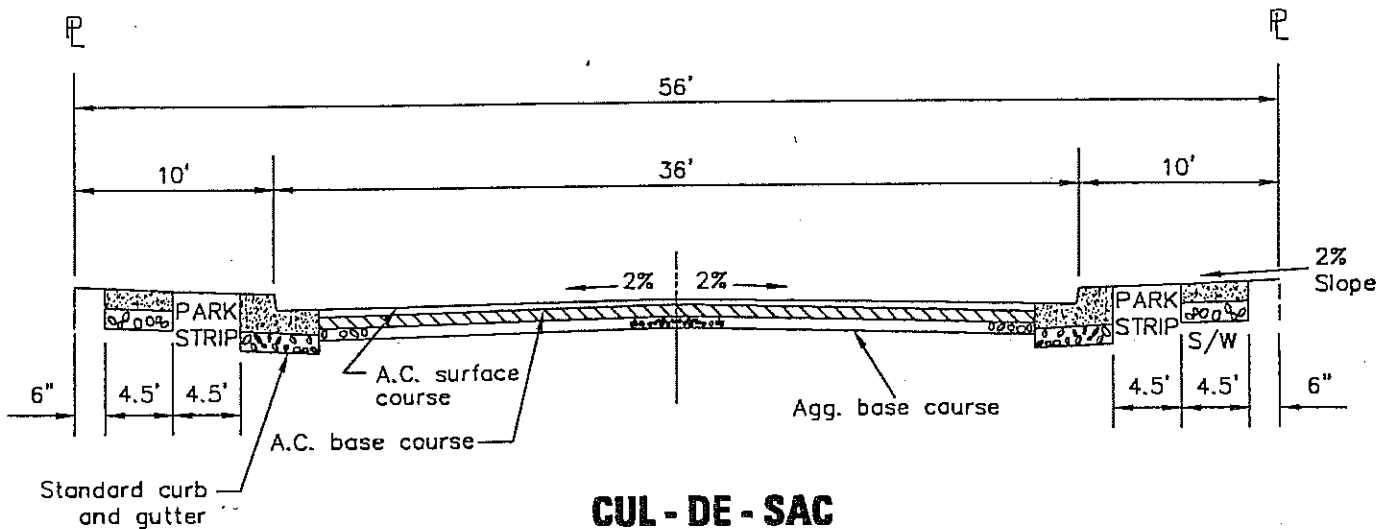

CUL - DE - SAC

(PARKING ON BOTH SIDES)

1. RESIDENTIAL - Sidewalk to be 4" P.C.C. over 4" Class II Aggregate Base @ 90% Relative Compaction
2. COMMERCIAL & INDUSTRIAL - Sidewalk to be 5" P.C.C. over 4" Class II Aggregate Base @ 90% Relative compaction.
3. Monolithic sidewalk shall be installed only when monolithic sidewalk exists.

RESIDENTIAL STREET SECTIONS

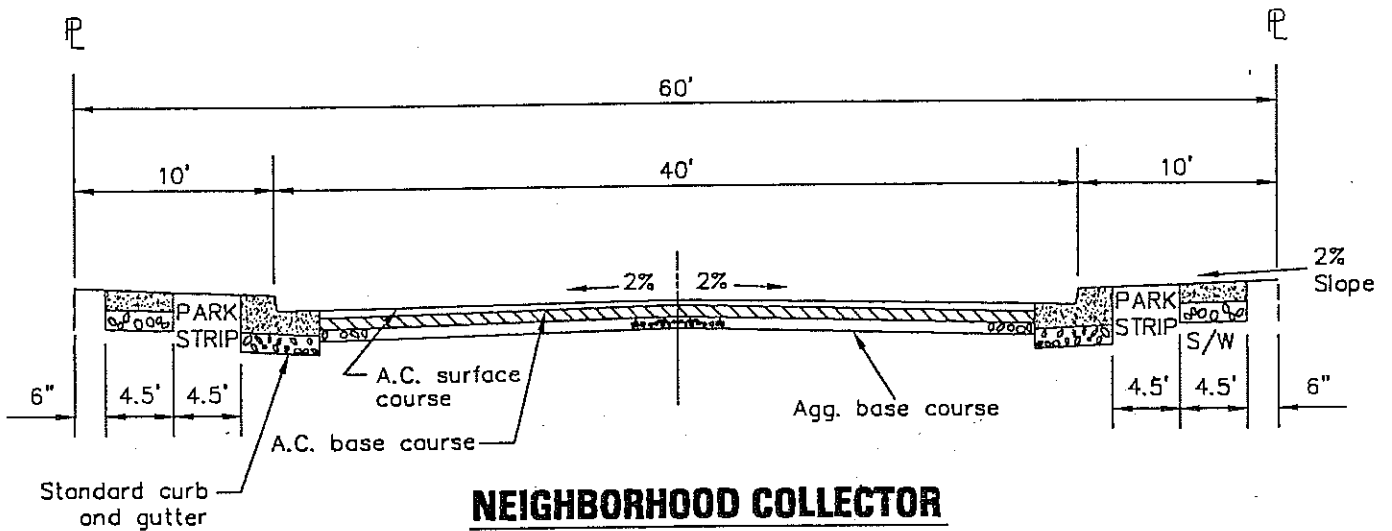
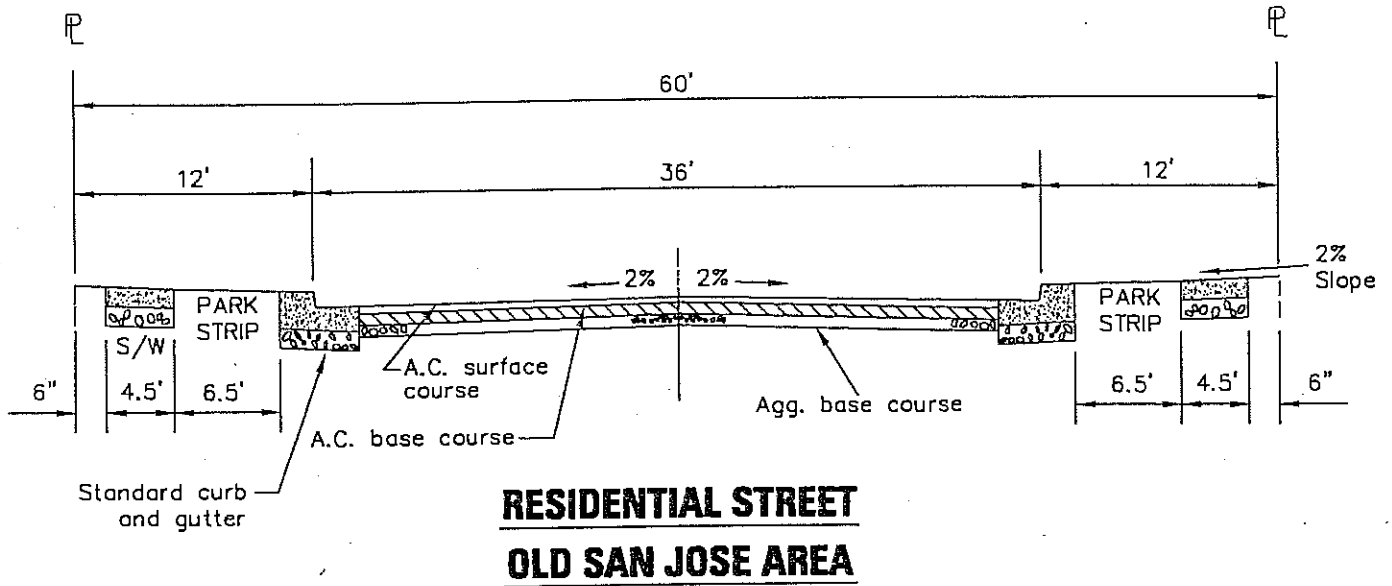

1. RESIDENTIAL - Sidewalk to be 4" P.C.C. over 4" Class II Aggregate Base @ 90% Relative Compaction
2. COMMERCIAL & INDUSTRIAL - Sidewalk to be 5" P.C.C. over 4" Class II Aggregate Base @ 90% Relative compaction.
3. Manolithic sidewalk shall be installed only when manolithic sidewalk exists.

RESIDENTIAL STREET SECTIONS

NOTE: Paved section to be designed based on R value and T.I. (Traffic Index)
 Min. paving section 2 1/2" A.C. on 8" Class II aggregate base.

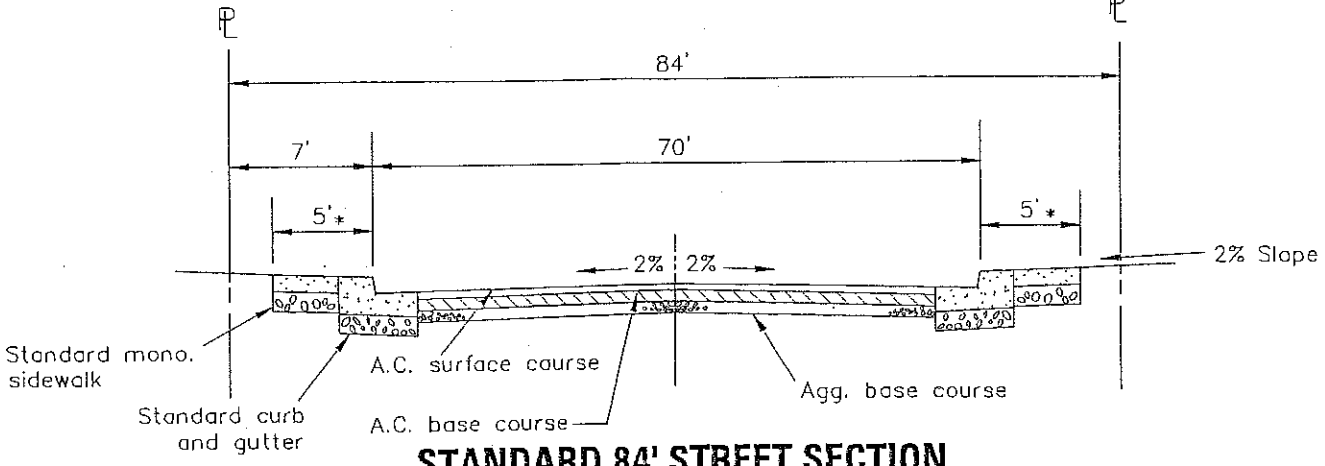

STANDARD 84' STREET SECTION

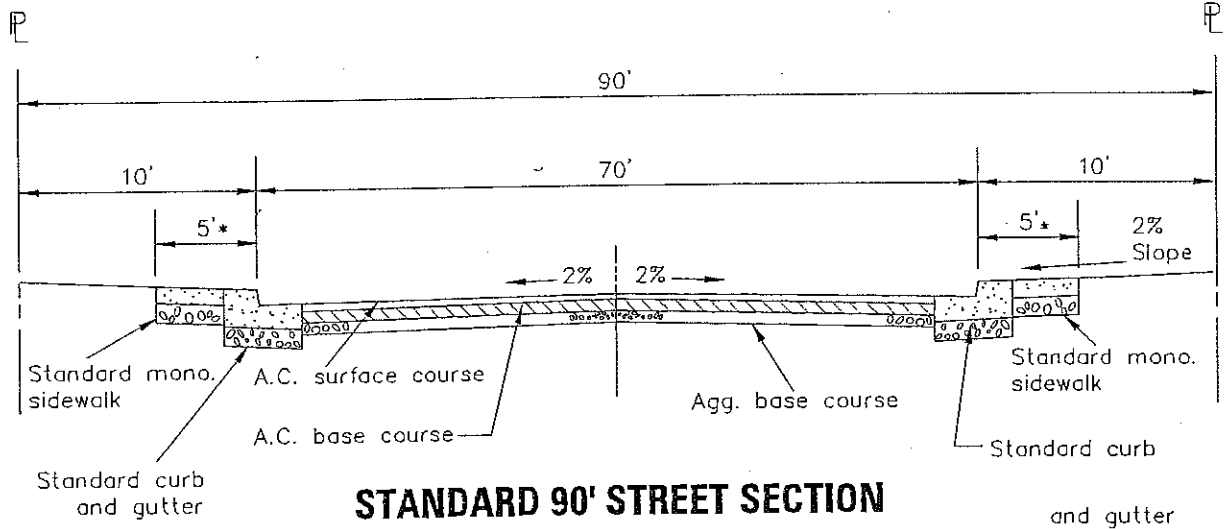

STANDARD 90' STREET SECTION

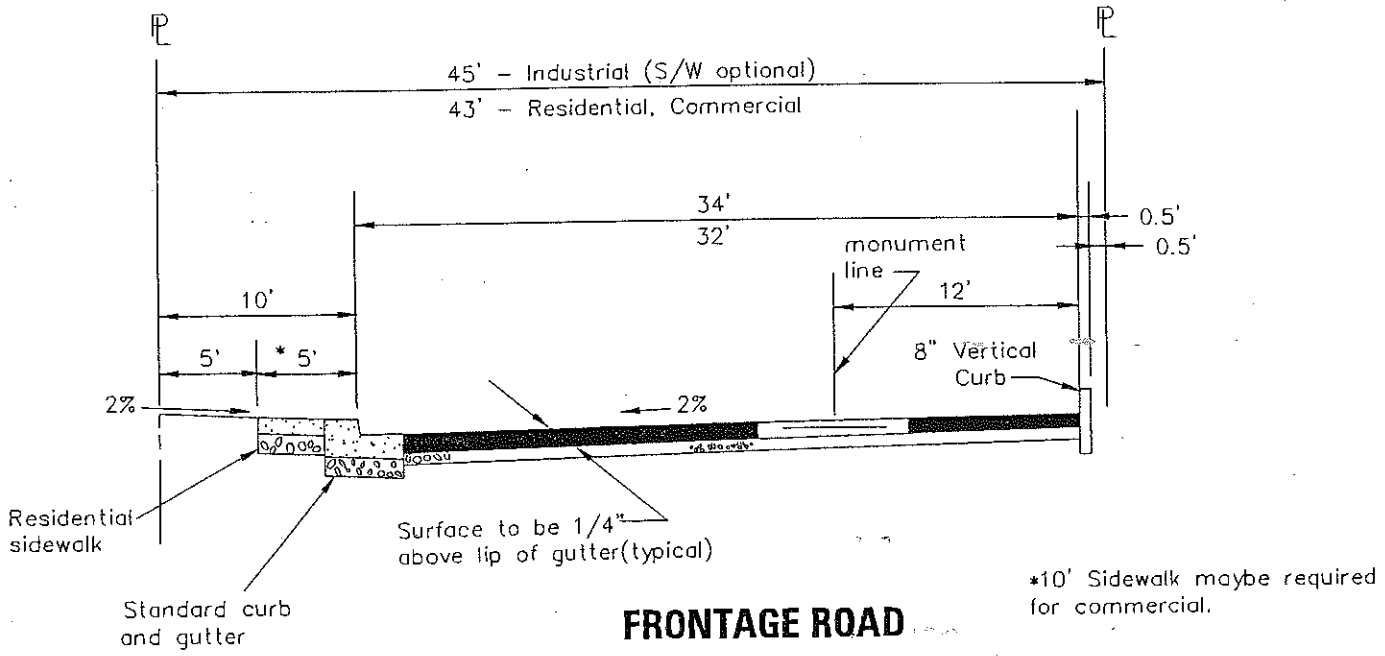

**FRONTAGE ROAD
 STANDARD STREET SECTIONS**

NOTE: Paved section to be designed based on R value and T.I. (Traffic Index) Min. paving section 2 1/2" A.C. on 8" Class II aggregate base. Traffic Index of greater than 7 shall require cement treated base or deep lift asphalt pavement.

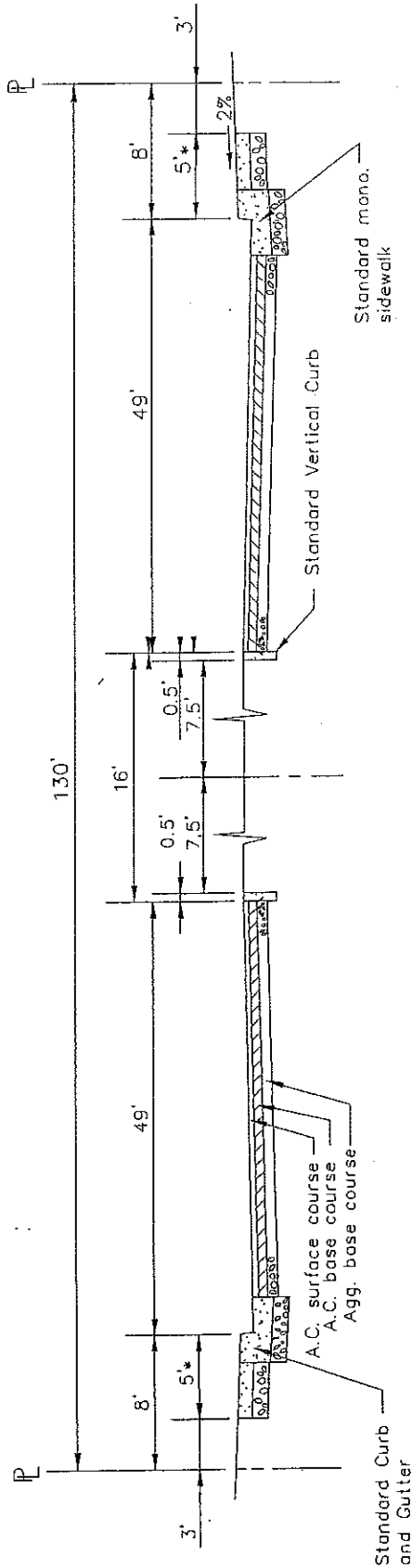

STANDARD 130' STREET SECTION

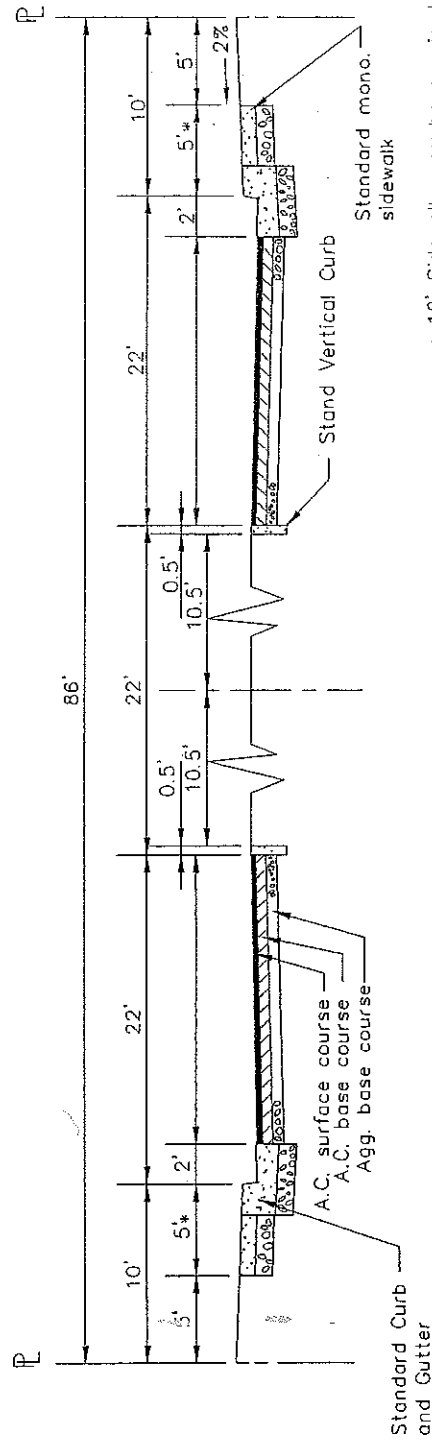

* 10' Sidewalk may be required for commercial.

STANDARD 86' STREET SECTION

STANDARD STREET SECTIONS

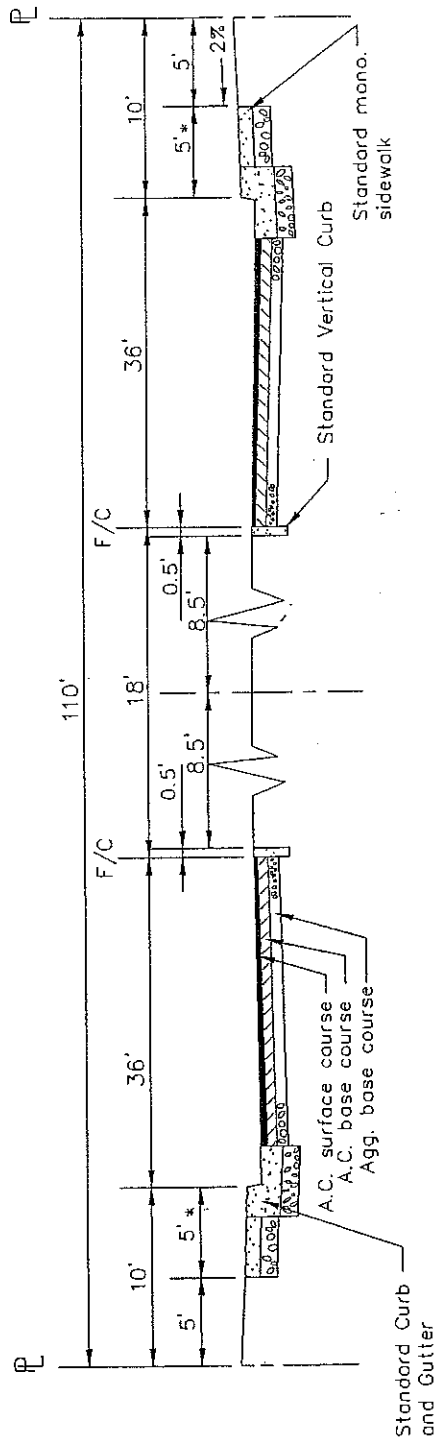

STANDARD 110' STREET SECTION

NOTE: Paved section to be designed based on R value and Traffic Index. Min. paving section 2 1/2" A.C. on 8" Class II aggregate base. Traffic Index of greater than 7 shall require cement treated base or deep lift asphalt pavement.

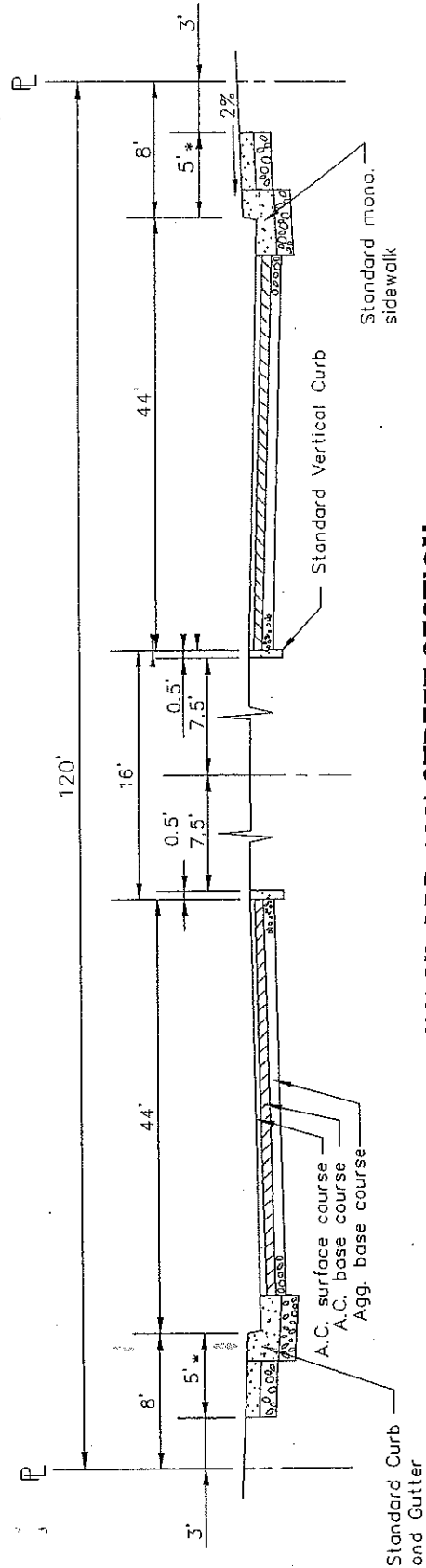

STANDARD 120' STREET SECTION

* 10' Sidewalk may be required for commercial.

STANDARD STREET SECTIONS

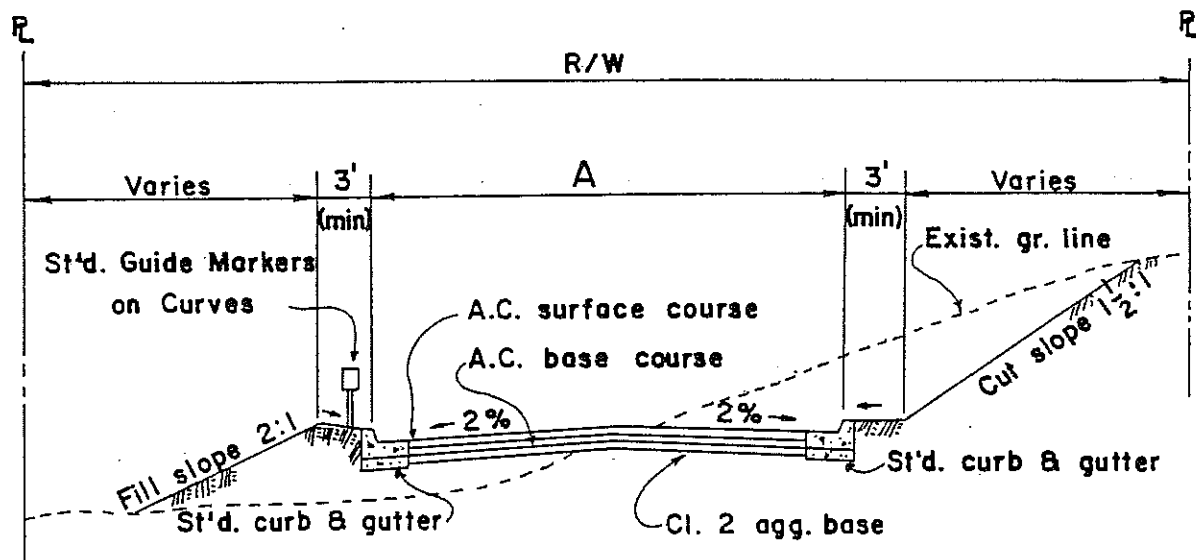
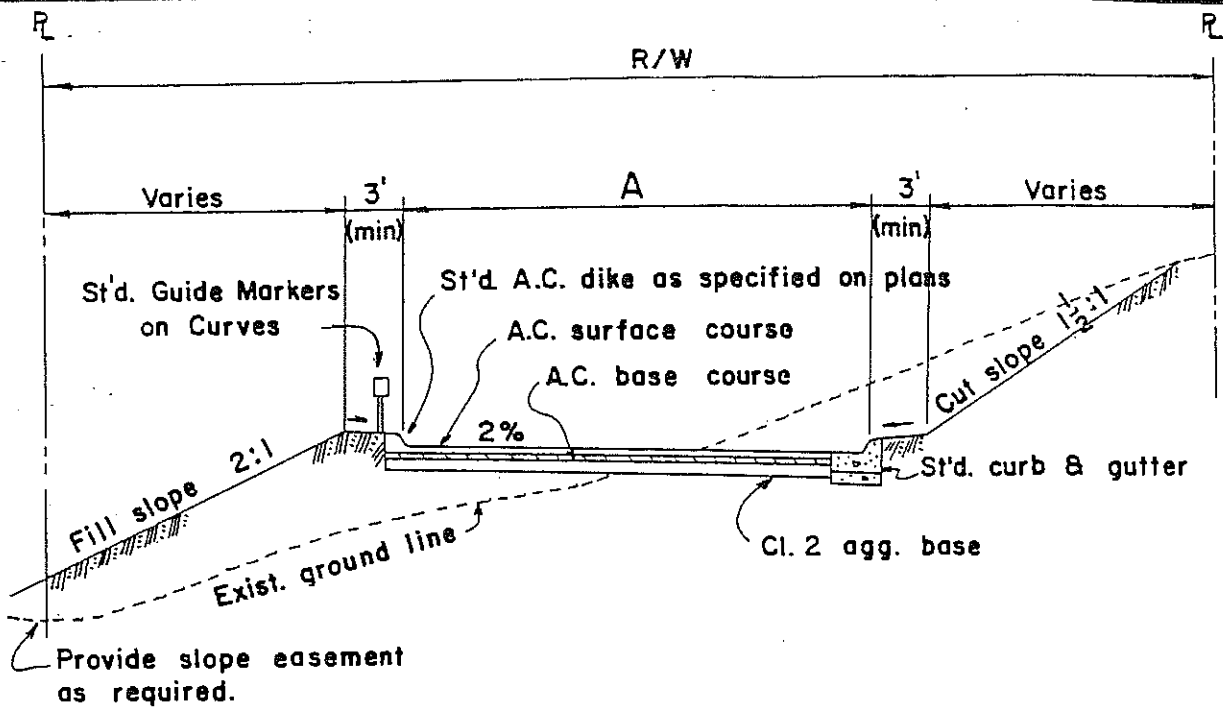

NOTE: Paved section to be designed based on R value and Traffic Index. Min. paving section 2 1/2" A.C. on 8" class 2 agg. base. Traffic Index of greater than 7 shall require cement treated base or deep lift asphalt pavement.

TYPE	A	R/W
One-way streets	14'	40'
Cul-de-sac 6 Lots or less max. potential	20'	40'
Cul-de-sac & local streets serving more than 6-Lots	24'	50'
Collector Streets	30'	60'
Major Streets	40'	60'

SPECIAL ROADWAY SECTIONS FOR HILLSIDE SUBDIVISIONS

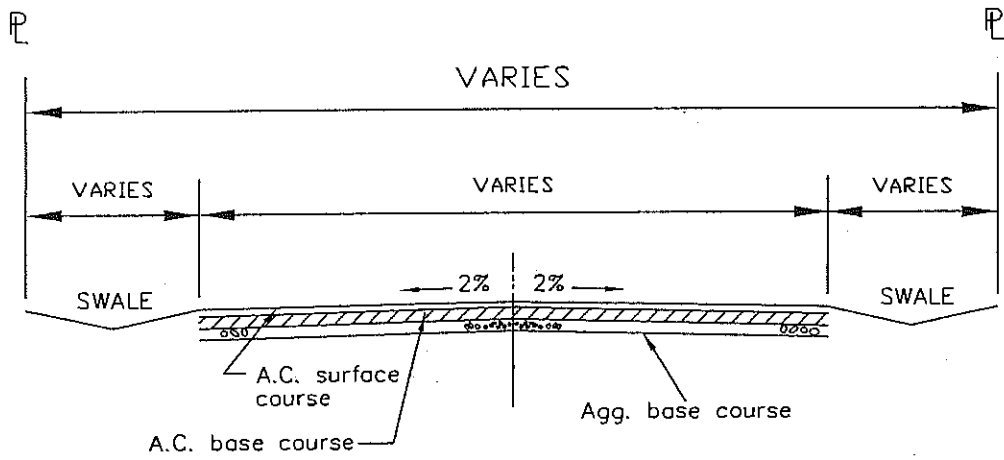

RURAL

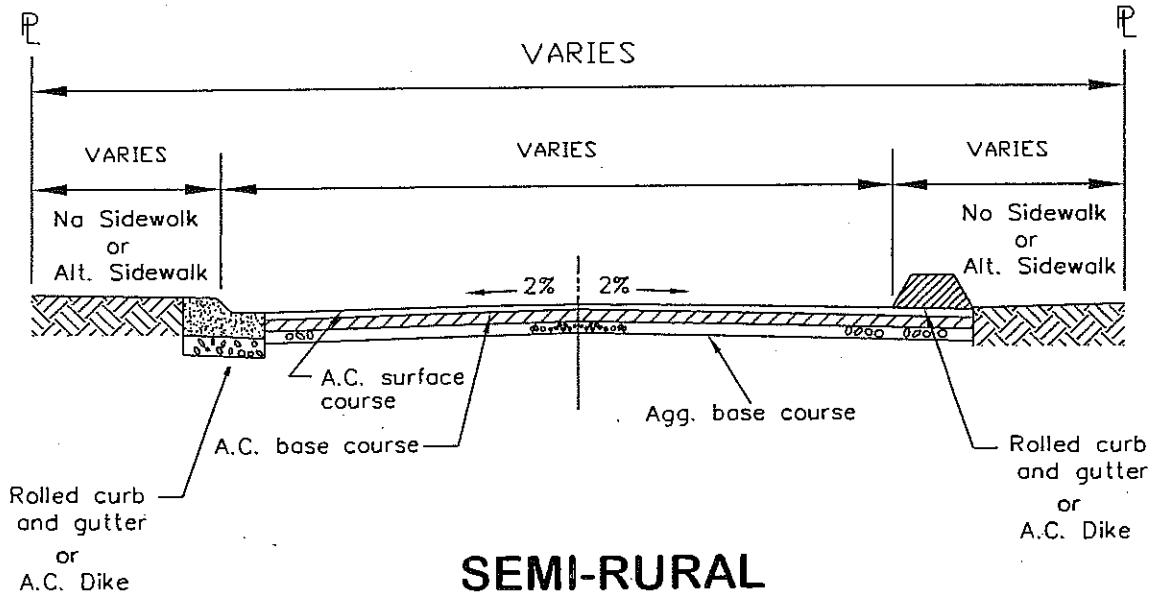

SEMI-RURAL

RURAL & SEMI-RURAL STREET SECTIONS

NOTE: Cul-De-Sac for existing dead-end street by approval of City Engineer and City Council.

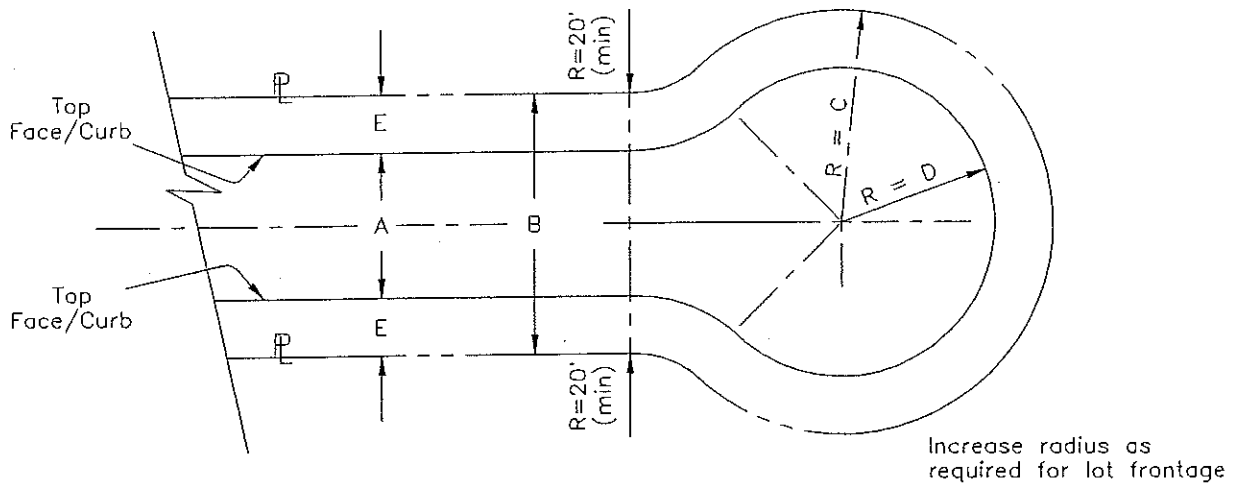
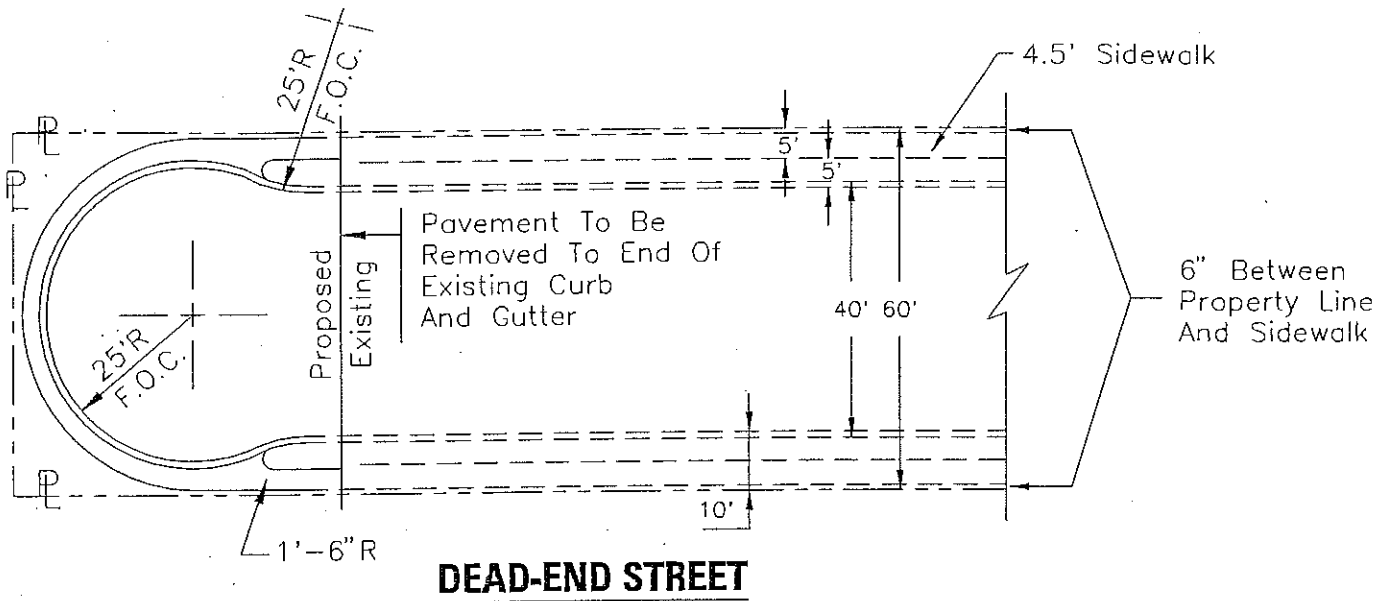

	A	B	C	D	E
INDUSTRIAL	40'	60'	60'	50'	5'
COMMERCIAL	40'	60'	55'	45'	10'
RESIDENTIAL (PARKING ON ONE SIDE)	28'	48'	46'	36'	10'
RESIDENTIAL (PARKING ON BOTH SIDES)	36'	56'	46'	36'	10'

Min. street section on cul-de-sac may be 2 1/2" A.C. on 8" Class II A.B. on approval of City Engineer.

CUL - DE - SACS

REVISED 6/9/97

CITY OF CUPERTINO
STANDARD DETAILS

APPROVED BY: 

CITY ENGINEER

DATE: 7-9-97

1-12

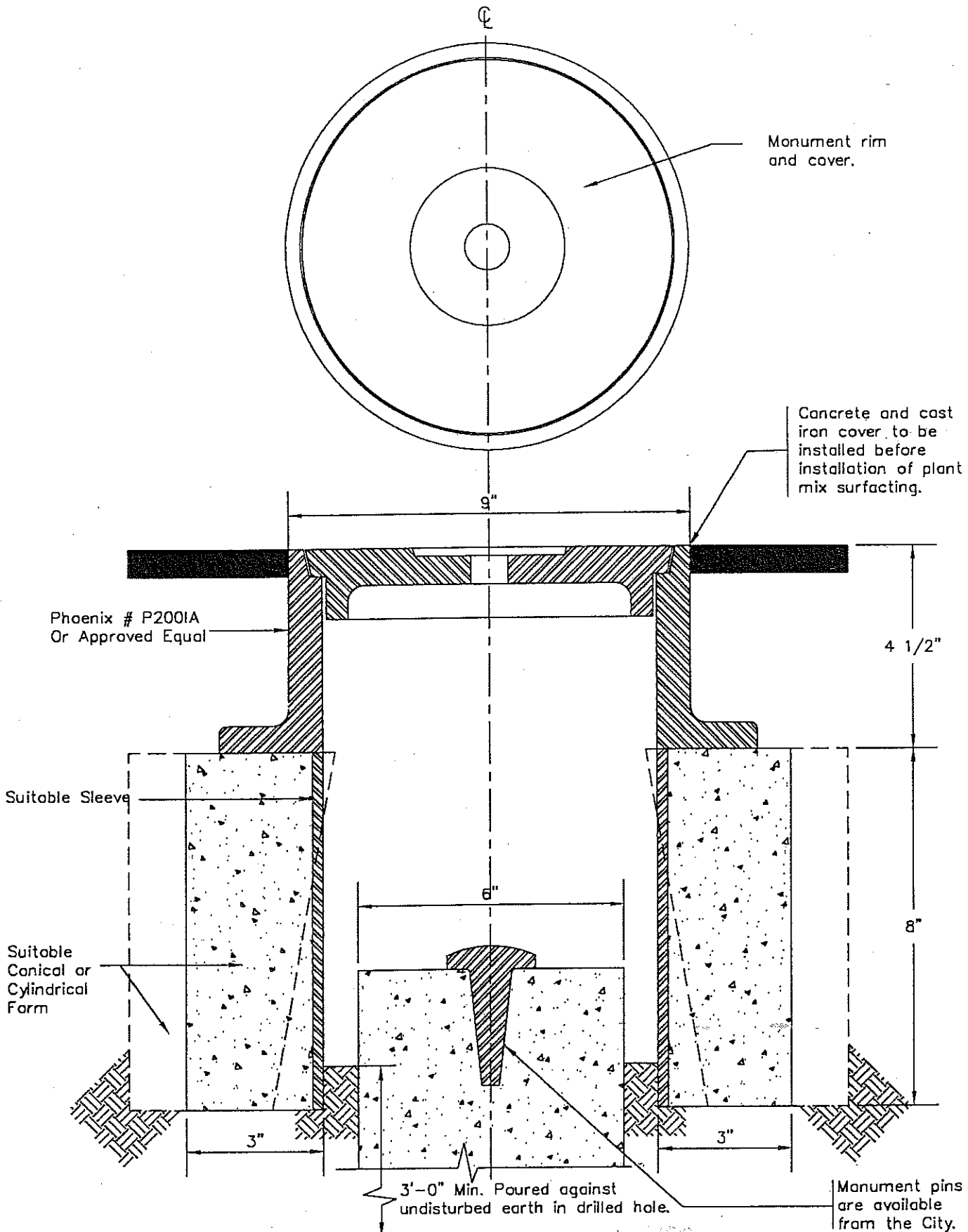

STREET MONUMENT

[Signature]
CITY ENGINEER

6/27/97

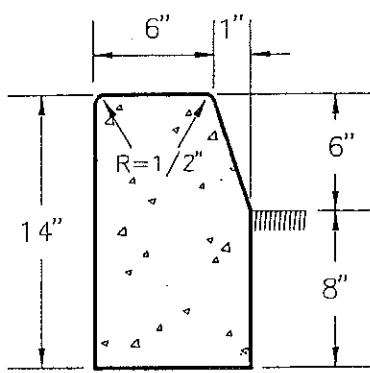

A1-6

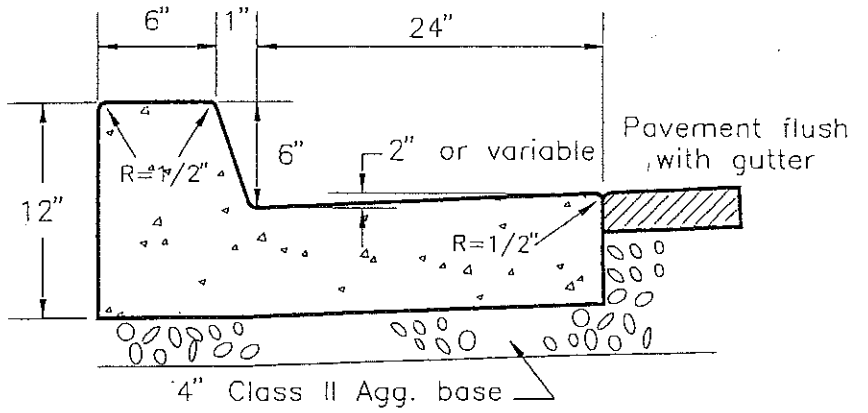

A2-6

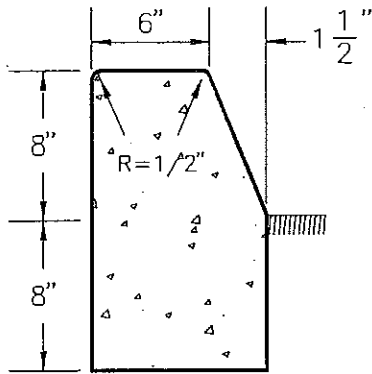

A1-8

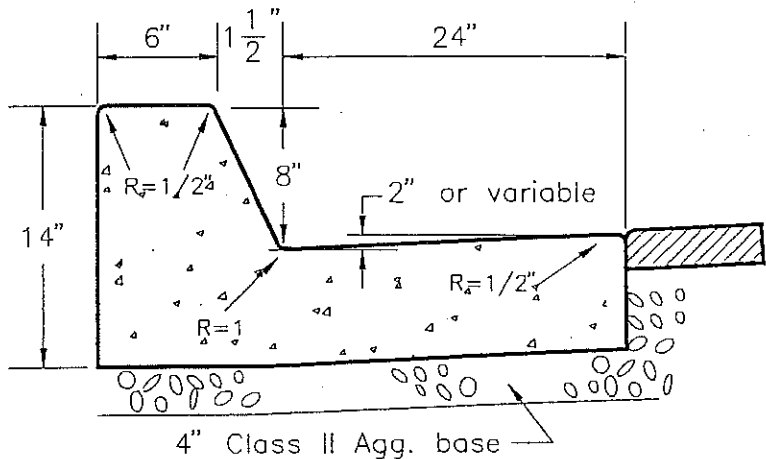

A2-8

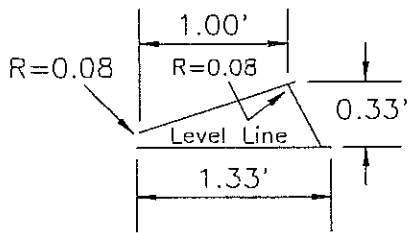

TYPE E (MOUNTABLE DIKE)

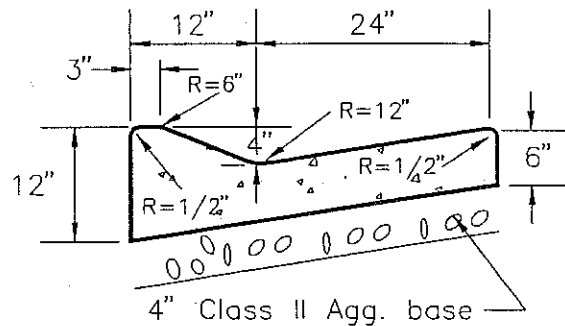

TYPE E

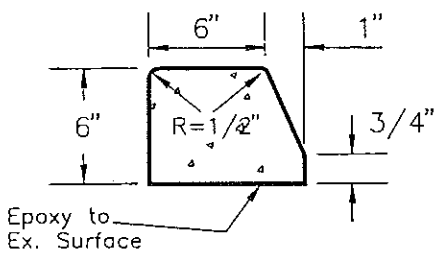

**EXTRUDED CURB
A3-6**

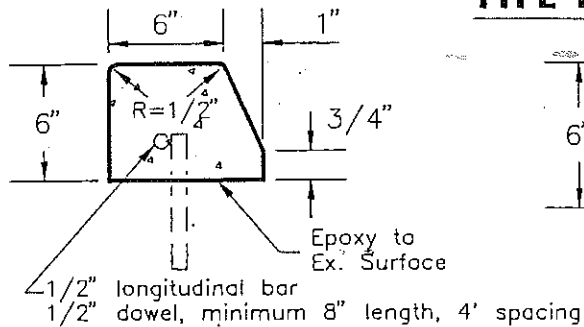

A3-6R

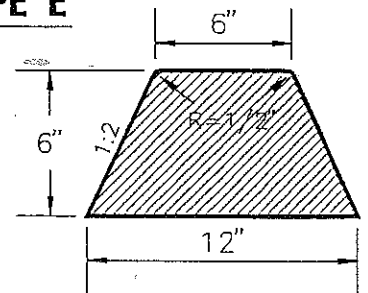

**A.C. DIKE
A3-6D**

STANDARD CURB SECTIONS

REVISED 3/97

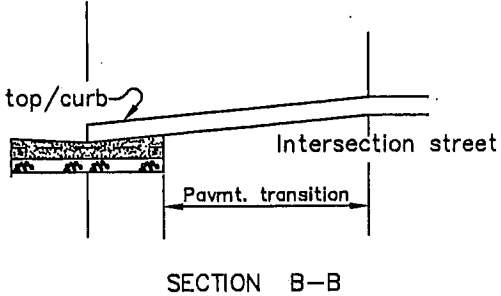
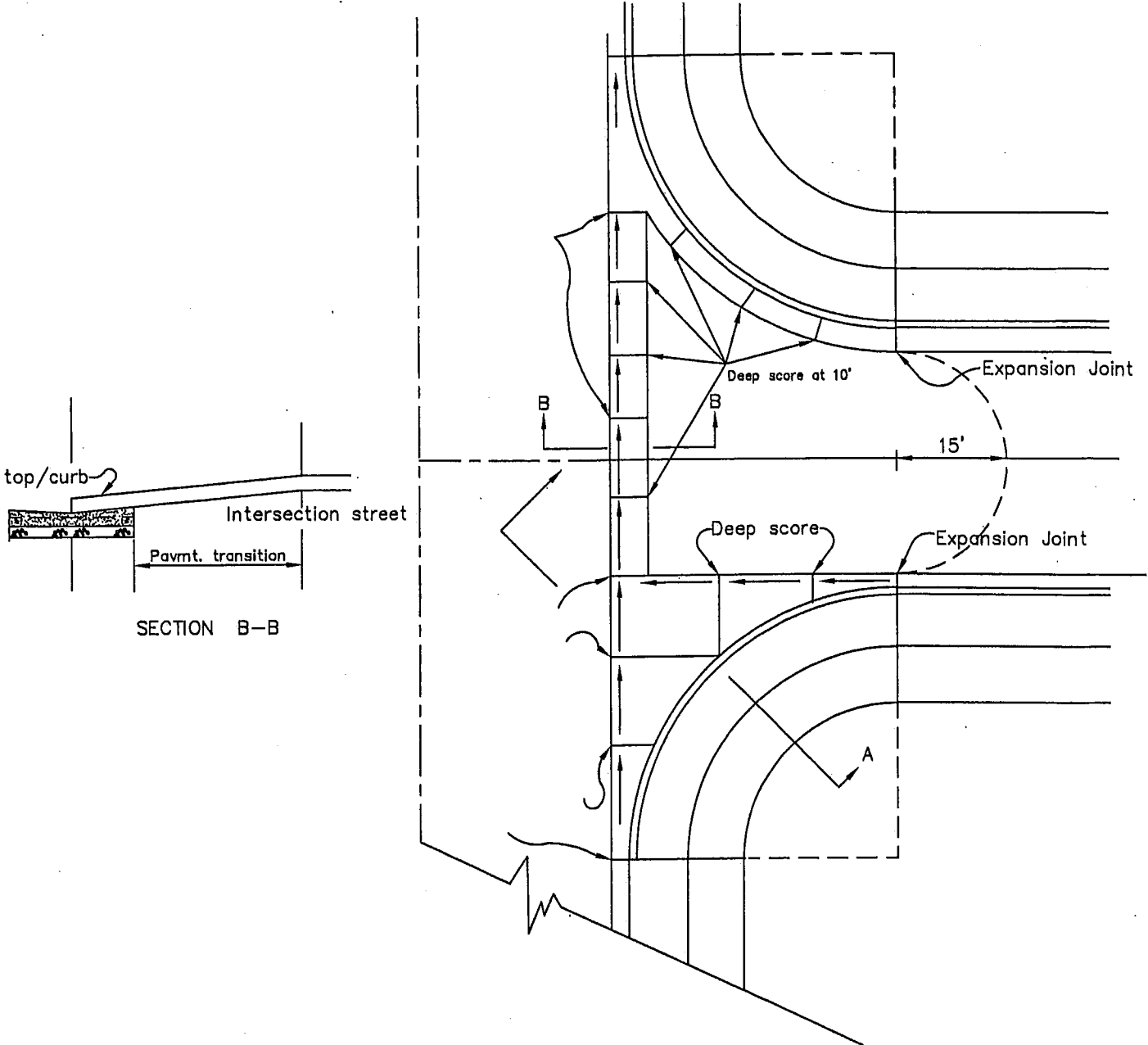

SECTION B-B

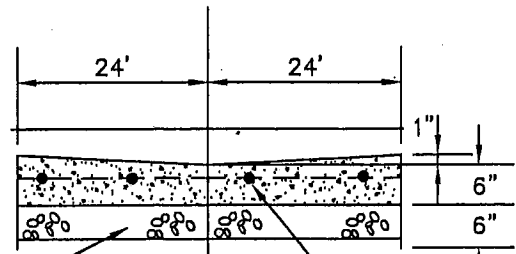

6" Class II Agg. base material with a 95% relative compaction

#4 Rebar, continuous longitudinal, 18" O.C. Perpendicular

TYPICAL SECTION

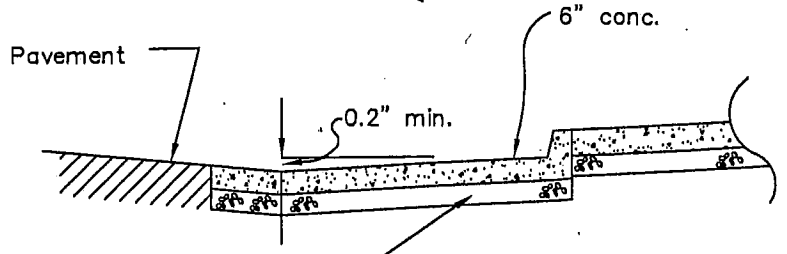

6" Class II Agg. base material with a 95% relative compaction

SECTION A-A

STANDARD VALLEY GUTTER

Revised 6/09

CITY OF CUPERTINO
STANDARD DETAILS

APPROVED BY: *Rachna G* DATE: 6.10.09
CITY ENGINEER

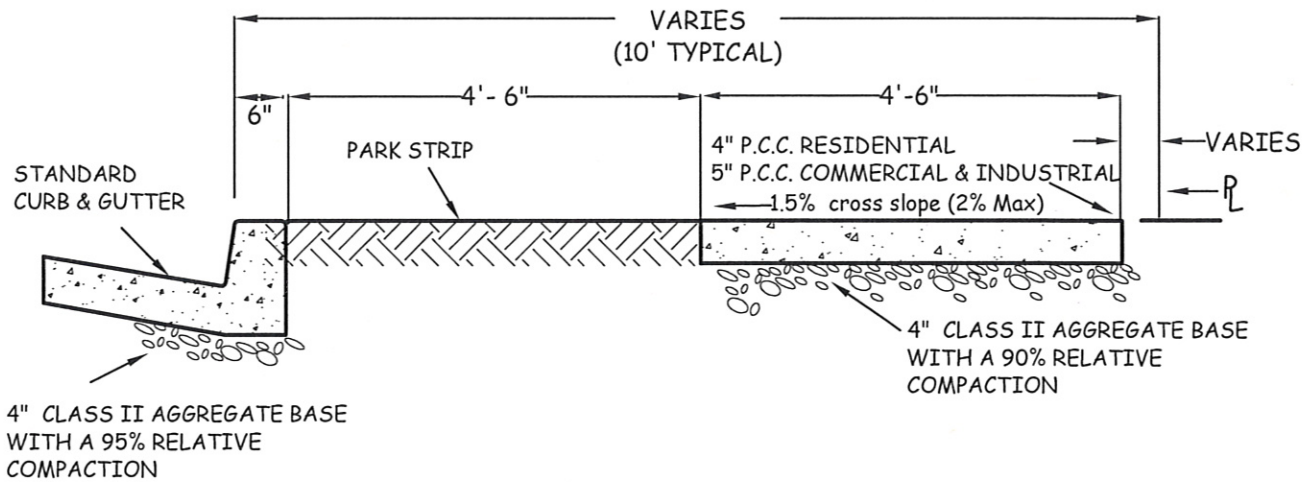
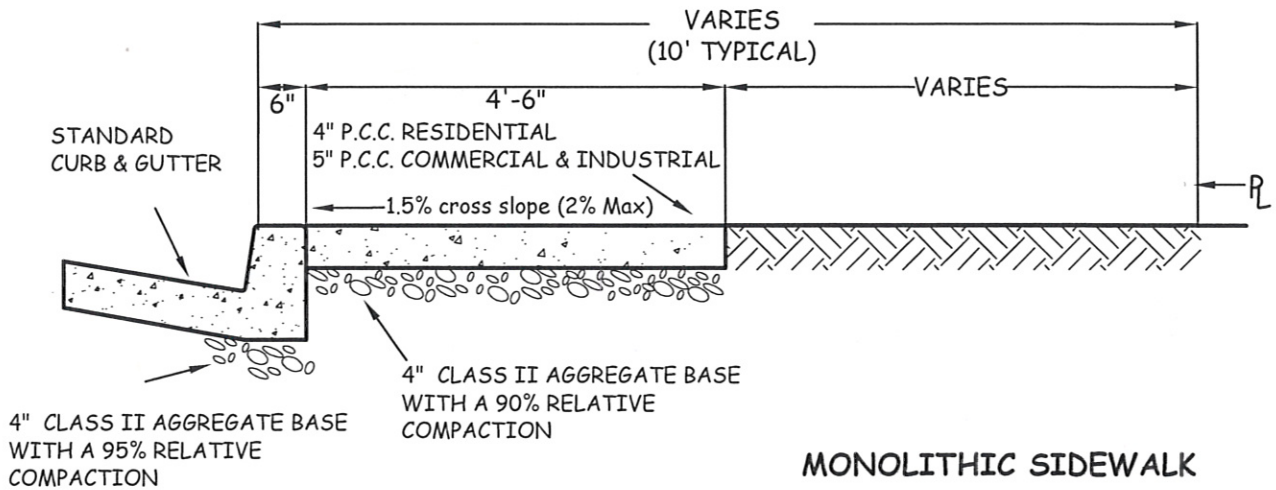

NOTES:

1. Cross slope shall be 1.5% (in no case shall cross slope exceed 2%)
2. Driveway concrete thickness: Residential - 5". Commercial and Industrial - 6" w/ #4 rebar 18" O.C. both ways.
3. One pound of dispersing black shall be mixed with each cubic yard of concrete at the batch plant.
4. Sidewalks, curbs and gutters shall be Class "A" (6 sacks per cubic yard) as per Standard Specification and shall attain a strength 3,000 p.s.i. in 28 days.
5. Sidewalk finish shall be light broom.

SIDEWALK DETAILS

REVISED 6/2016

CITY OF CUPERTINO
STANDARD DETAILS

APPROVED BY:



City Engineer

DATE: 6/29/16

1-19

TABLE "A"

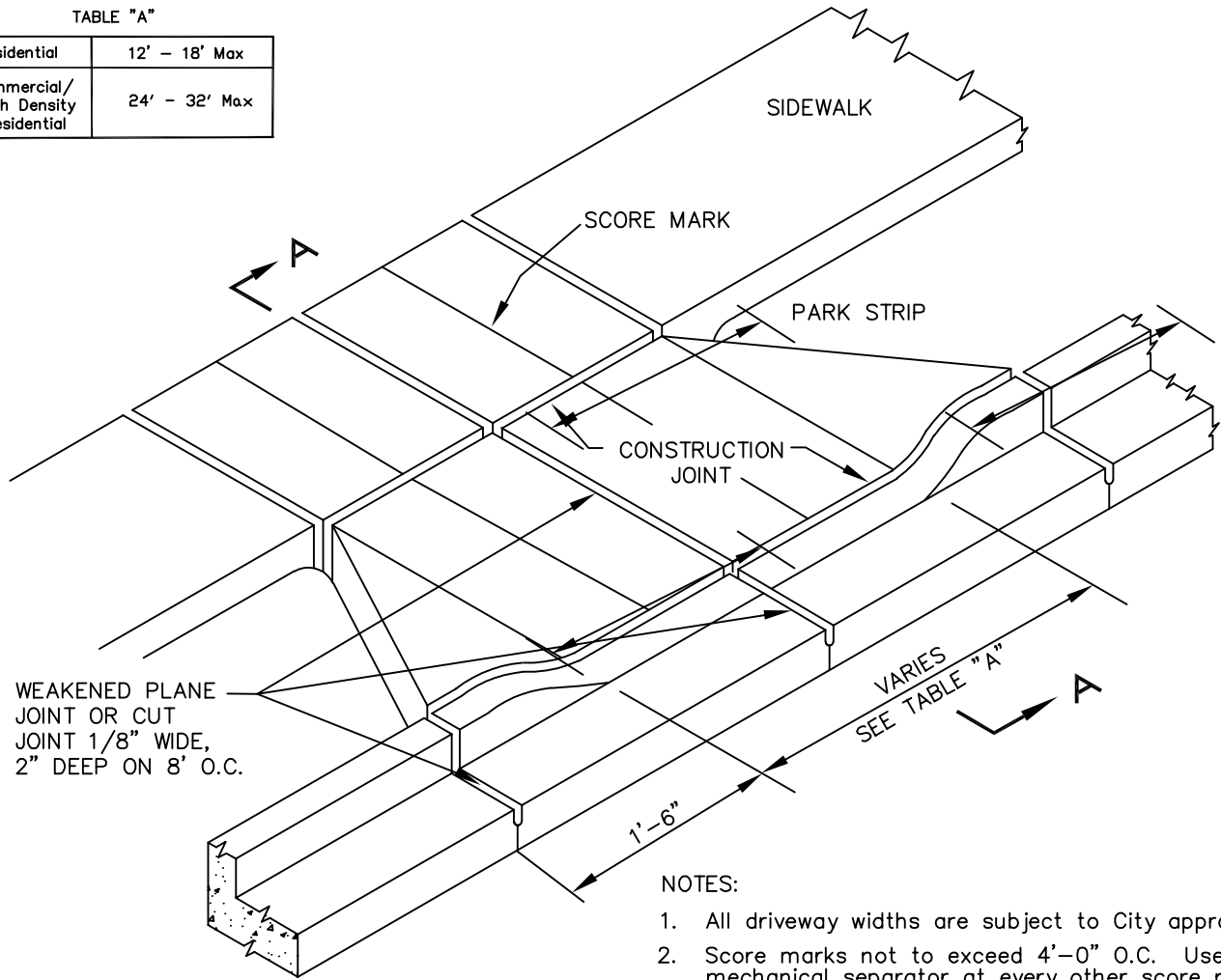
Residential	12' - 18' Max
Commercial/ High Density Residential	24' - 32' Max



NOTES:

1. All driveway widths are subject to City approval.
2. Score marks not to exceed 4'-0" O.C. Use mechanical separator at every other score mark.
3. Finish to be light broom.
4. Sidewalk to be replaced when new driveway is placed.
5. Edge of driveway shall be a minimum of 4' from property line.
6. Cross slope shall be 1.5%. In no case shall cross slope exceed 2%.

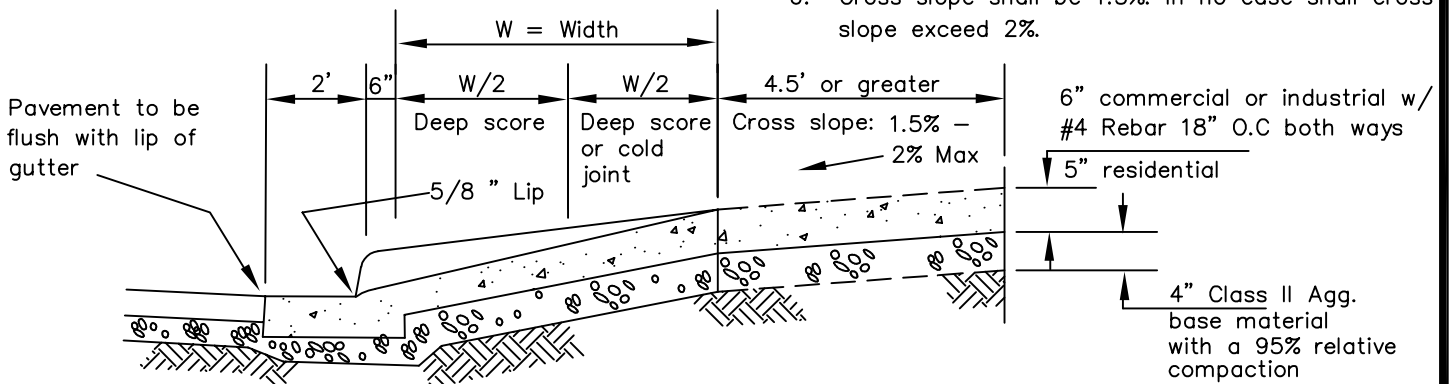

SECTION A - A

DRIVEWAY DETAIL - DETACHED SIDEWALK

REVISED 2/2020

TABLE "A"

Residential	12' - 18' Max
Commercial/ High Density Residential	24' - 32' Max

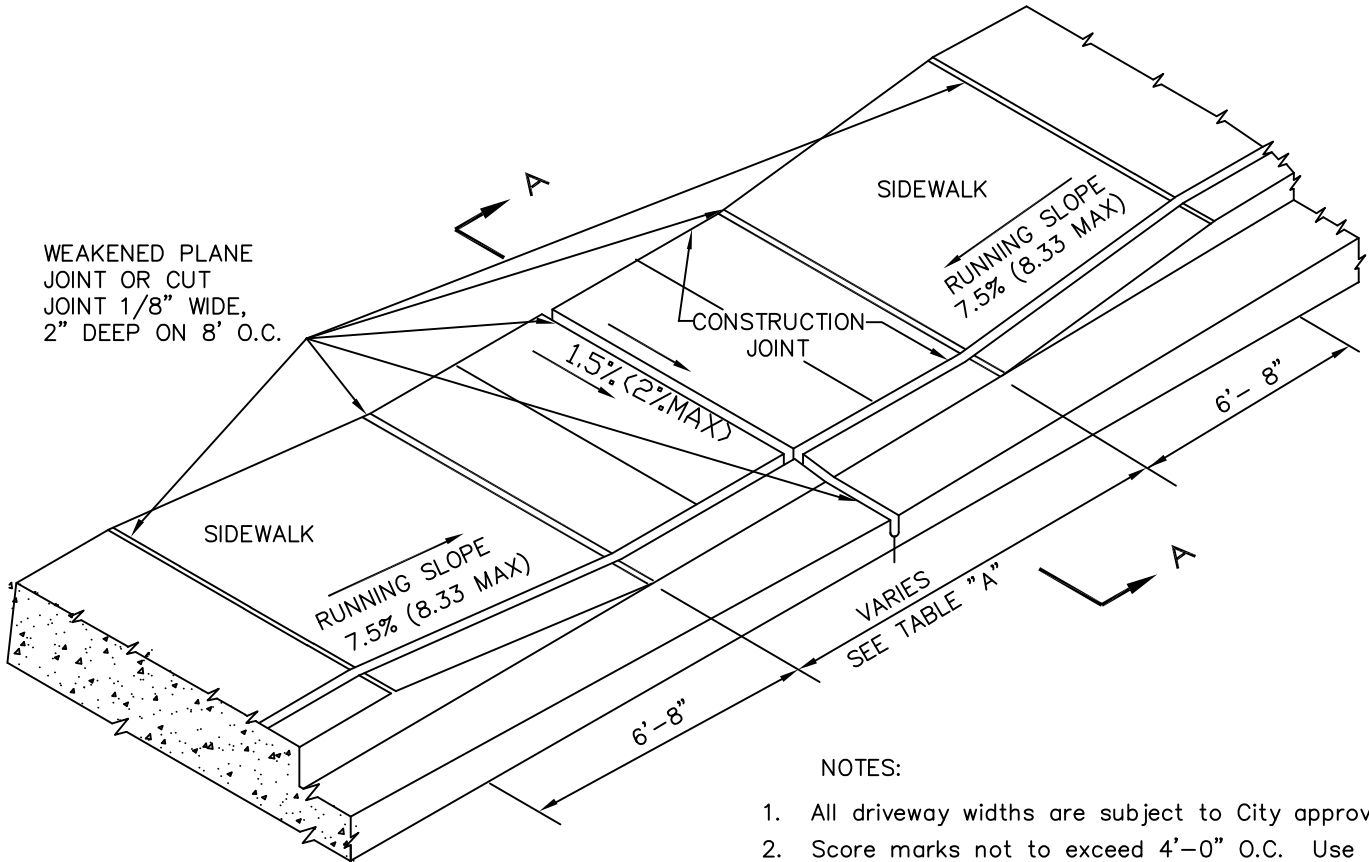

NOTES:

1. All driveway widths are subject to City approval.
2. Score marks not to exceed 4'-0" O.C. Use mechanical separator at every other score mark.
3. Finish to be light broom
4. Sidewalk to be replaced when new driveway is placed.
5. Edge of driveway shall be a minimum of 6'-8" from property line.
6. If on-street parking is permitted, driveway shall be flush with gutter.
7. Running slope shall be 7.5%. In no case shall running slope exceed 8.33%.

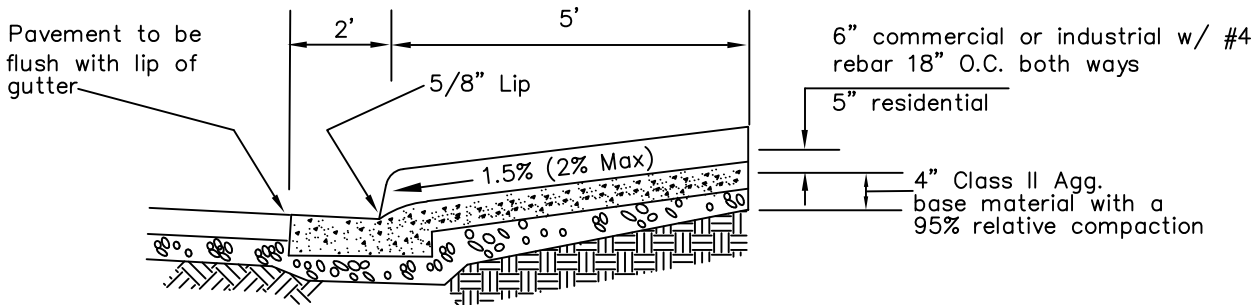

SECTION A - A

DRIVEWAY DETAIL - MONOLITHIC SIDEWALK

REVISED 2/2020

TABLE "A"

Residential	12'-18' Max
-------------	-------------

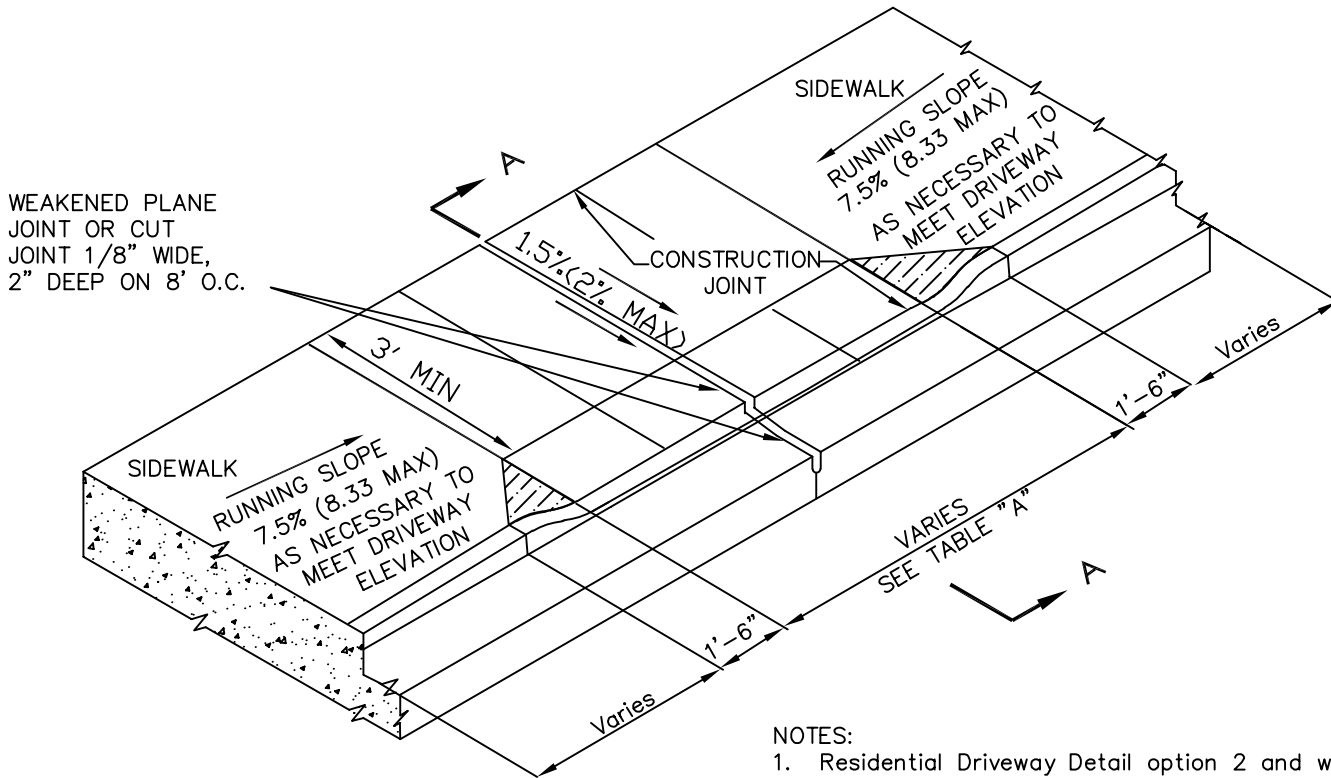

WEAKENED PLANE
JOINT OR CUT
JOINT 1/8" WIDE,
2" DEEP ON 8' O.C.

NOTES:

1. Residential Driveway Detail option 2 and width for monolithic sidewalk may be used only with written approval from the City Engineer.
2. Score marks not to exceed 4'-0" O.C. Use mechanical separator at every other score mark.
3. Finish to be light broom
4. Sidewalk to be replaced when new driveway is placed.
5. Edge of driveway shall be a minimum of 4' from property line.
6. Running slope shall be 7.5%. In no case shall running slope exceed 8.33%.

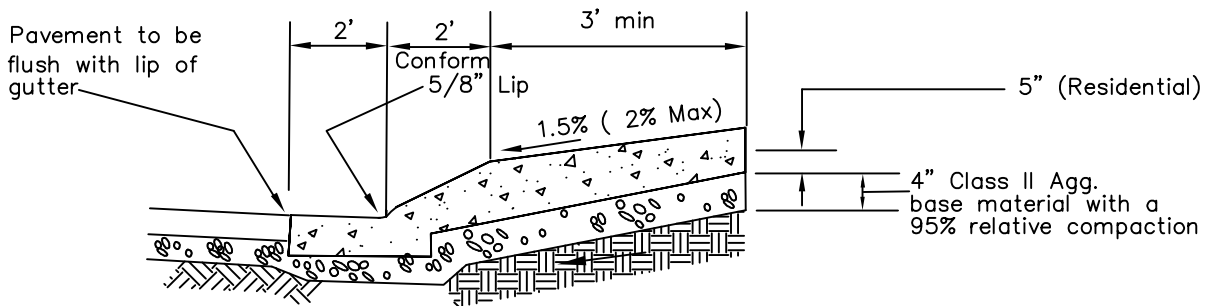

SECTION A - A

DRIVEWAY DETAIL - MONOLITHIC SIDEWALK OPTION 2 (For Residential Only)

REVISED 2/2020

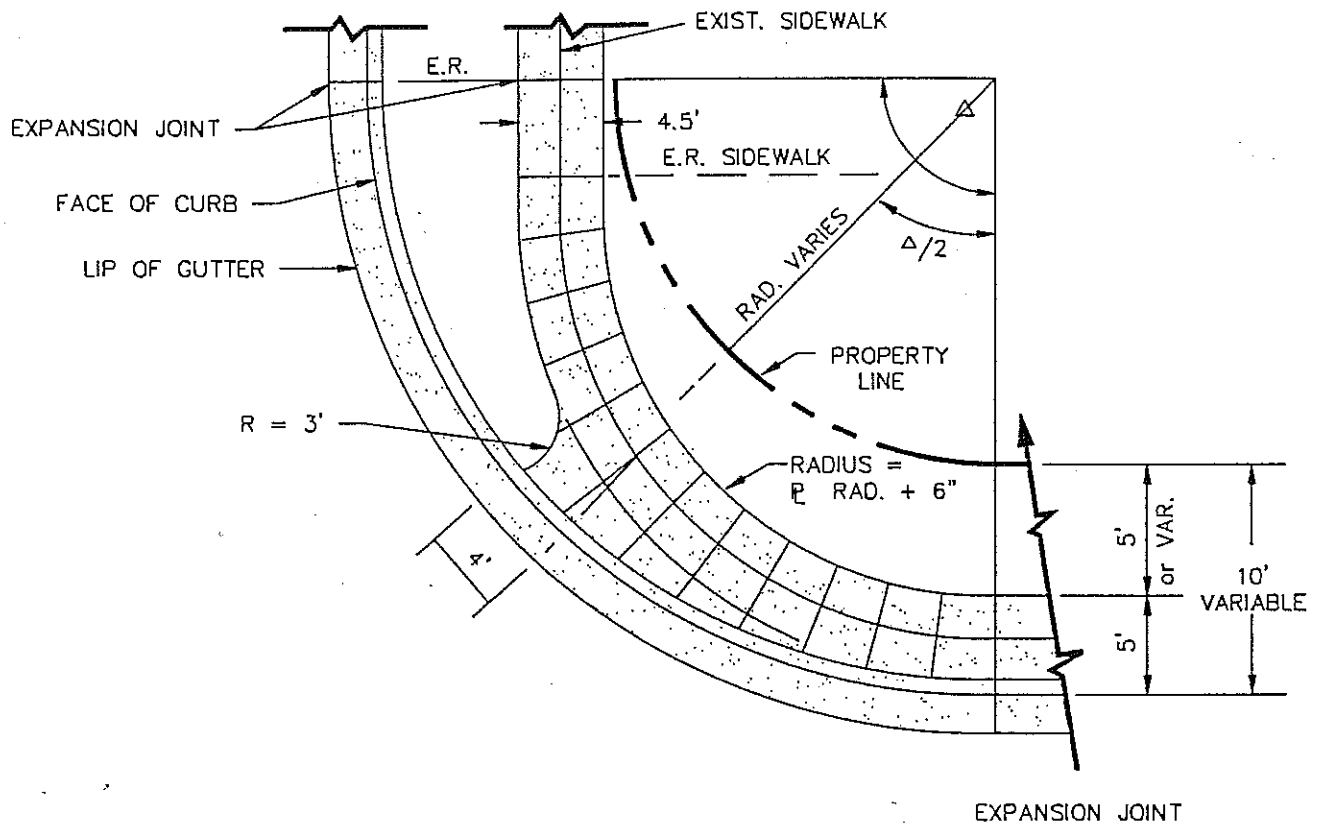

SIDEWALK CORNER TRANSITION
FROM EXISTING SIDEWALK W/PLANTER STRIP
TO NEW MONOLITHIC SIDEWALK

USE 7" LONG, #4 DOWEL
DRILL HOLES, BLOW CLEAN,
AND SET DOWELS IN EPOXY.

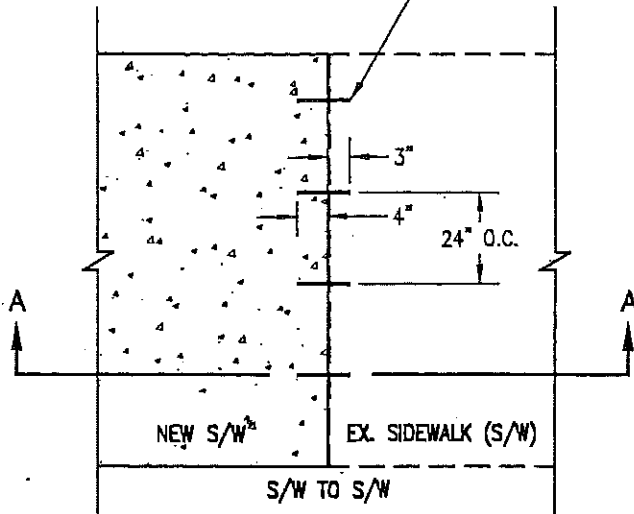

PLAN VIEW
NO SCALE

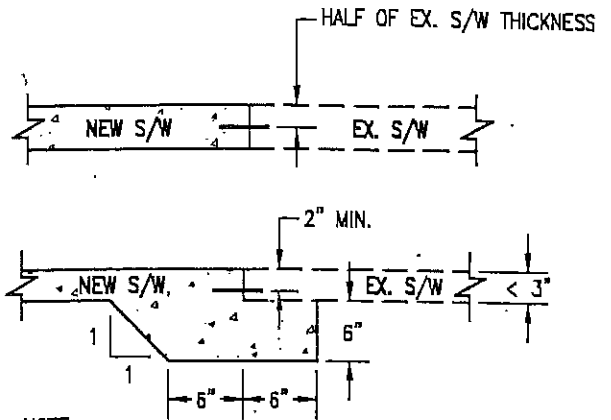

NOTE:

IF EXISTING SIDEWALK IS LESS THAN 3" THICK,
USE 6" DEEP X 12" WIDE P.C.C. KEY WITH
DOWEL CONNECTION.

SECTION A-A
NO SCALE

USE 7" LONG, #4 DOWEL
DRILL HOLES, BLOW CLEAN,
AND SET DOWELS IN EPOXY.

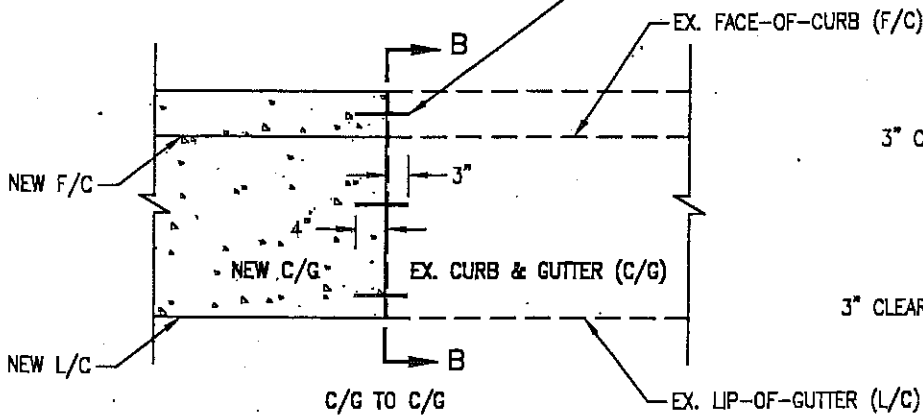

PLAN VIEW
NO SCALE

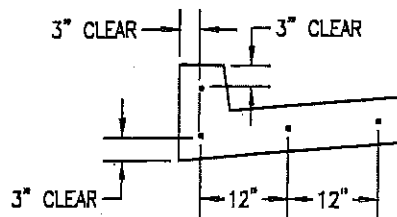

SECTION B-B
NO SCALE

DOWEL CONNECTIONS

June 2009

CITY OF CUPERTINO
STANDARD DETAILS

APPROVED BY: *[Signature]*
CITY ENGINEER

DATE: 6-10-09

1-23

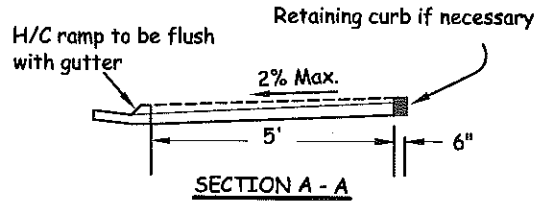
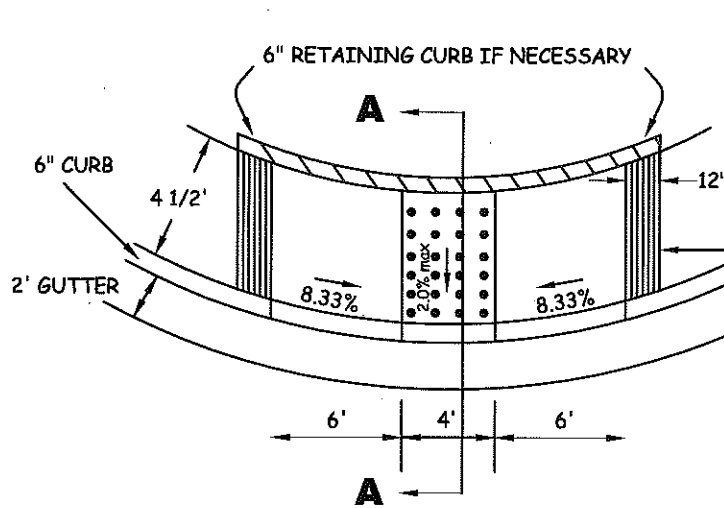

NOTE: IF SIDEWALK IS LESS THAN 5', FULL WIDTH OF SIDEWALK SHALL BE DEPRESSED.

CASE A - 5' MONOLITHIC SIDEWALK

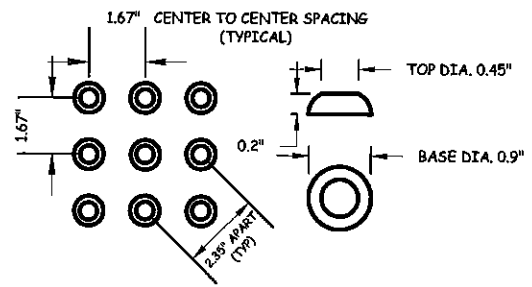

DETECTABLE WARNING SURFACE
YELLOW CAST IN PLACE COMPOSITE
TACTILE BY ADA SOLUTIONS, INC.

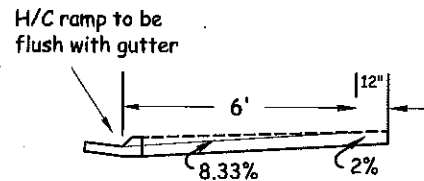
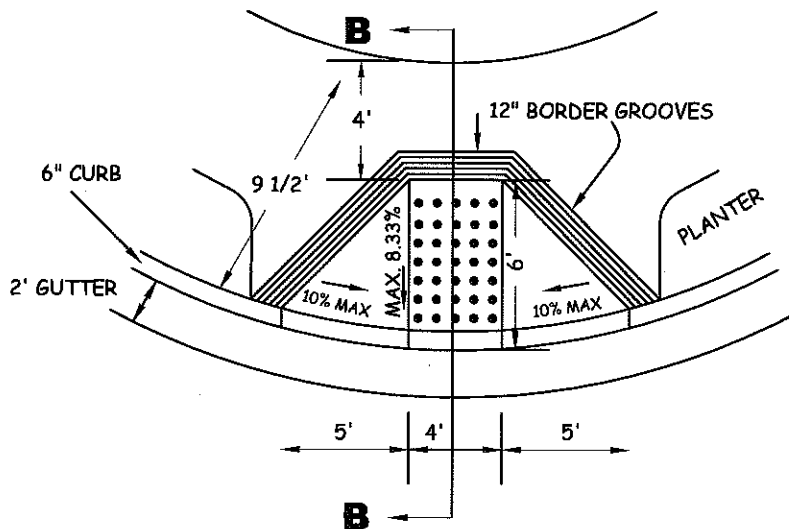

SECTION B - B

CASE B - DETACHED SIDEWALK OR 10' MONOLITHIC SIDEWALK

NOTES

1. RAMP TO BE MINIMUM 4" P.C.C. ON 3" CLASS 2 AGGREGATE BASE WITH HEAVY BROOM FINISH TRANSVERSE TO AXIS OF RAMP.
2. CURB RAMPS TO BE PLACED MONOLITHICALLY WITH CURB, GUTTER & SIDEWALK
3. CURB RAMPS SHALL HAVE DETECTABLE WARNING SURFACE THAT EXTENDS THE FULL WIDTH AND DEPTH OF THE CURB RAMP. DETECTABLE WARNING SURFACE SHALL CONFORM TO THE DETAILS ON THIS PLAN. USE YELLOW CAST IN PLACE COMPOSITE TACTILE BY ADA SOLUTIONS, INC. OR CITY APPROVED EQUAL. INSTALL PER MANUFACTURERS SPECIFICATION.
4. THE EDGE OF THE DETECTABLE WARNING SURFACE NEAREST THE STREET SHALL BE BETWEEN 6" AND 8" FROM THE GUTTER FLOWLINE
5. CURB RAMP INSTALLATION SHALL COMPLY WITH CALTRANS STANDARD PLAN A88A IF FIELD CONDITIONS DIFFER.

CURB RAMP DETAILS

CITY OF CUPERTINO
STANDARD DETAILS

APPROVED BY: *[Signature]* DATE: 7.27.10
City Engineer

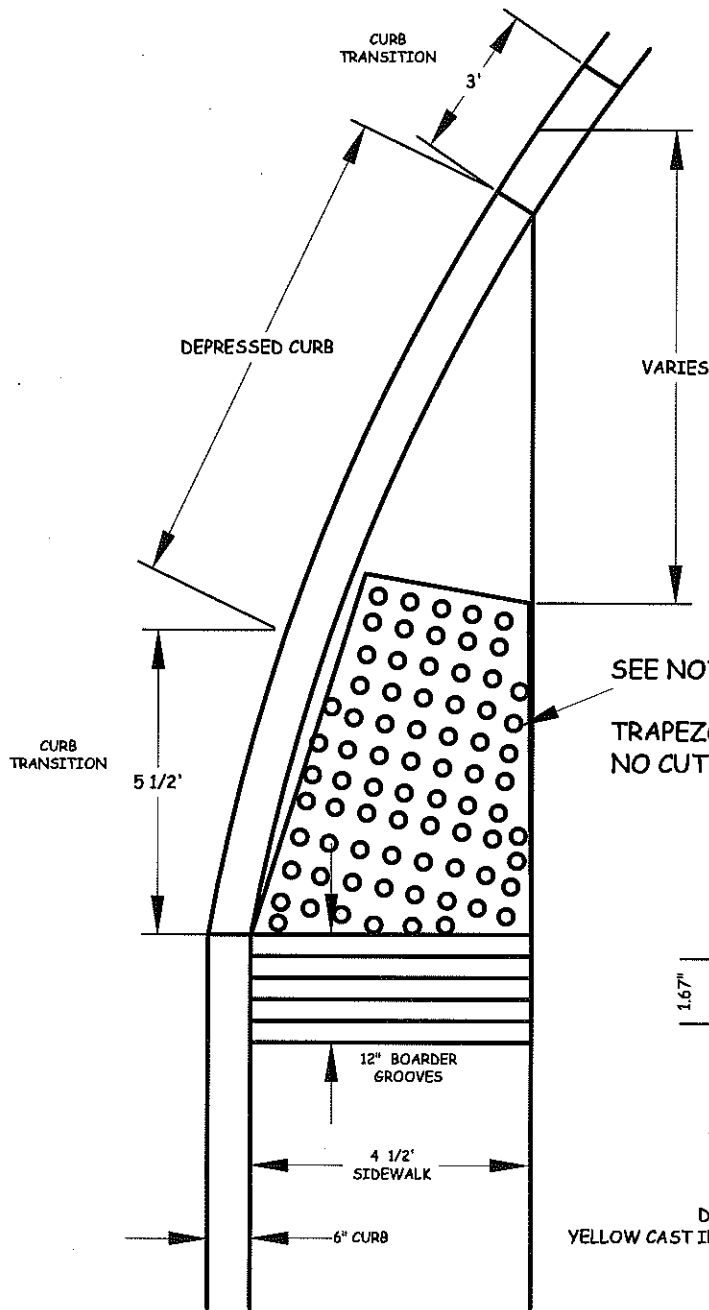

H/C ramp to be flush with gutter

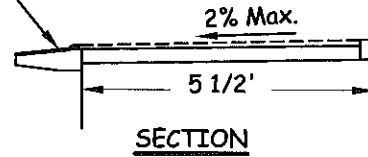

NOTE: IF SIDEWALK IS LESS THAN 5', FULL WIDTH OF SIDEWALK SHALL BE DEPRESSED.

SEE NOTES 3,4

TRAPEZOID PLATE TO BE ADJUSTED TO FIT. NO CUTTING RECOMMENDED.

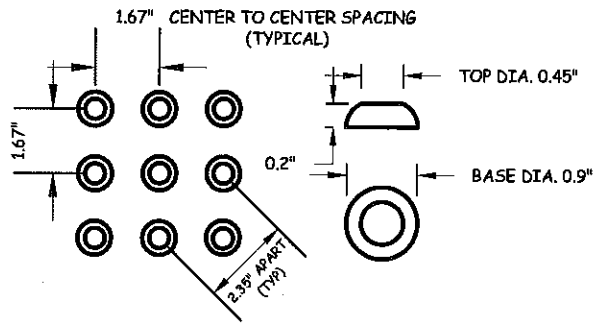

DETECTABLE WARNING SURFACE DETAILS
YELLOW CAST IN PLACE COMPOSITE TACTILE BY ADA SOLUTIONS, INC.

CASE C

NOTES

1. RAMP TO BE MINIMUM 4" P.C.C. ON 3" CLASS 2 AGGREGATE BASE WITH HEAVY BROOM FINISH TRANSVERSE TO AXIS OF RAMP.
2. CURB RAMPS TO BE PLACED MONOLITHICALLY WITH CURB, GUTTER & SIDEWALK
3. CURB RAMPS SHALL HAVE DETECTABLE WARNING SURFACE THAT EXTENDS THE FULL WIDTH AND DEPTH OF THE CURB RAMP. DETECTABLE WARNING SURFACE SHALL CONFORM TO THE DETAILS ON THIS PLAN. USE YELLOW CAST-IN-PLACE COMPOSIT TACTILE BY ADA SOLUTIONS, INC. (LARGE TRAPEZOID 36"X24") OR CITY APPROVED EQUAL. INSTALL PER MANUFACTURERS SPECIFICATION.
4. THE EDGE OF THE DETECTABLE WARNING SURFACE NEAREST THE STREET SHALL BE BETWEEN 6" AND 8" FROM THE GUTTER FLOWLINE
5. CURB RAMP INSTALLATION SHALL COMPLY WITH CALTRANS STANDARD PLAN A88A IF FIELD CONDITIONS DIFFER.

CURB RAMP DETAIL

CITY OF CUPERTINO
STANDARD DETAILS

APPROVED BY:

R. U. U. U. U.

DATE: 7.27.10

City Engineer

1-25

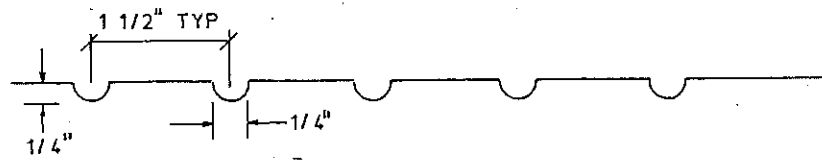
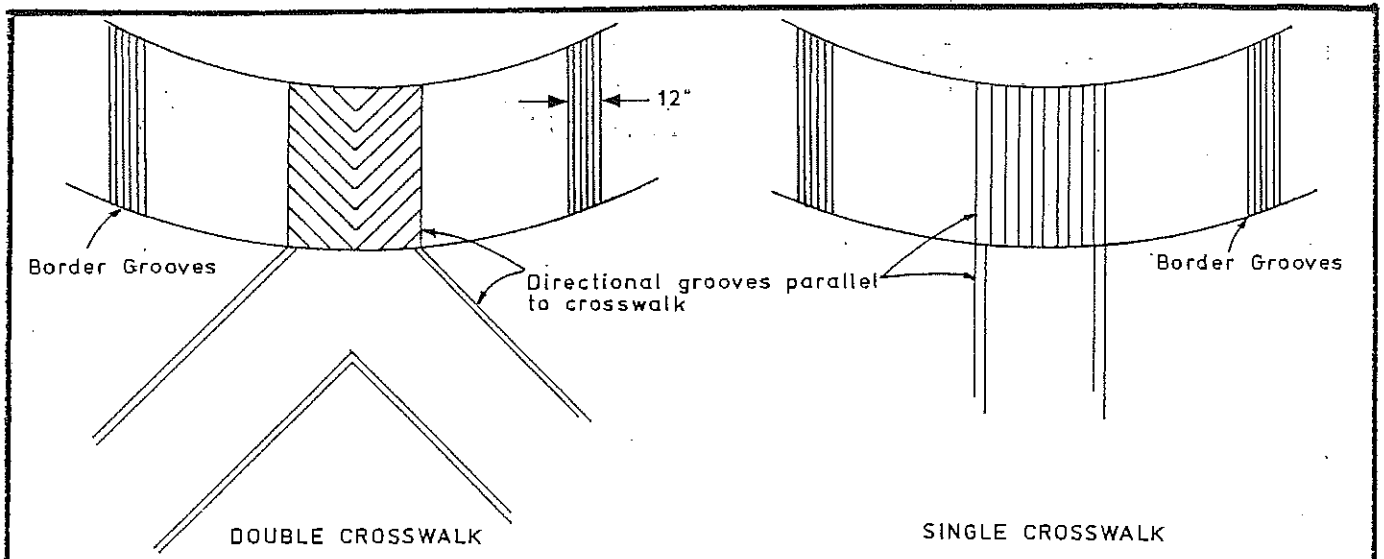

DIRECTIONAL GROOVE DETAIL

THE SURFACE OF EACH CURB RAMP LOCATED IN THE CENTER OF THE CURB RETURN SHALL BE GROOVED PARALLEL TO THE CENTERLINE OF THE CROSSWALKS TYPICALLY IN TWO DIRECTIONS WITH 1/4 INCH X 1/4 INCH (6.35mm X 6.35mm) GROOVES 1 1/2 INCHES (38.1mm) ON CENTER. WHERE ONLY ONE CROSSWALK EXISTS, RAMP SHALL BE GROOVED IN ONE DIRECTION ONLY, PARALLEL WITH THE EXISTING CROSSWALK.

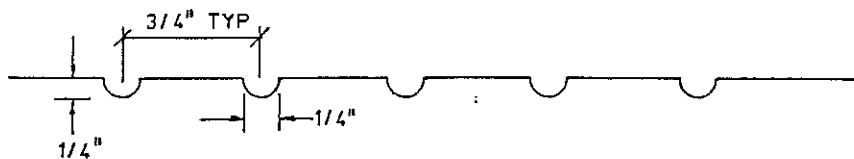

BORDER GROOVE DETAIL

ALL CURB RAMPS SHALL HAVE A GROOVED BORDER 12 INCHES (304.8mm) WIDE AT THE LEVEL SURFACE OF THE SIDEWALK ALONG THE TOP AND EACH SIDE 3/4 INCH (19.05mm) ON CENTER.

HANDICAP RAMP DETAILS

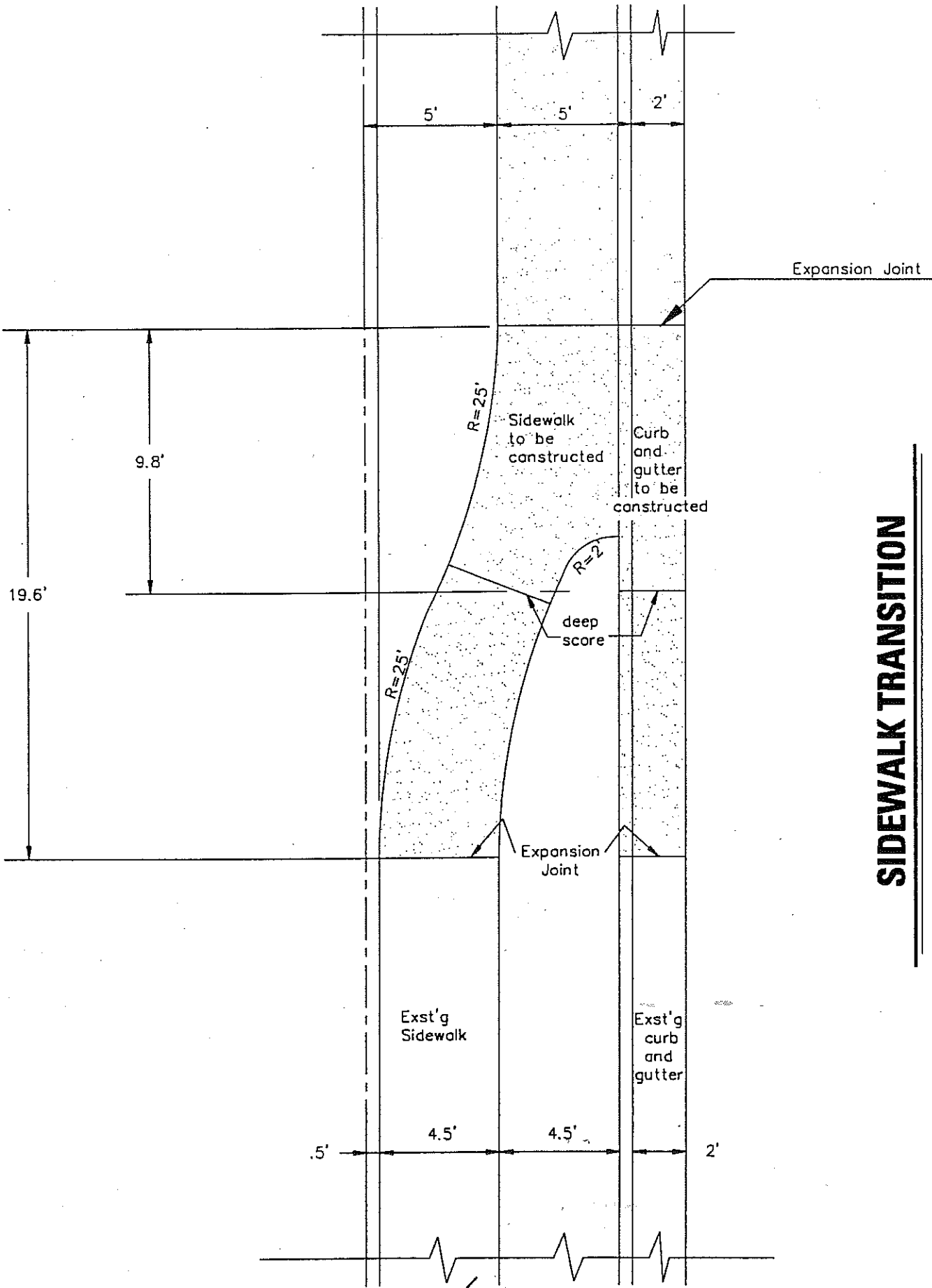

SIDEWALK TRANSITION

[Signature]
CITY ENGINEER

SIDEWALK TRANSITION AROUND EXISTING ELECTROLIER
FIRE HYDRANT, UTILITY POLE, OR OTHER
OBSTRUCTIONS

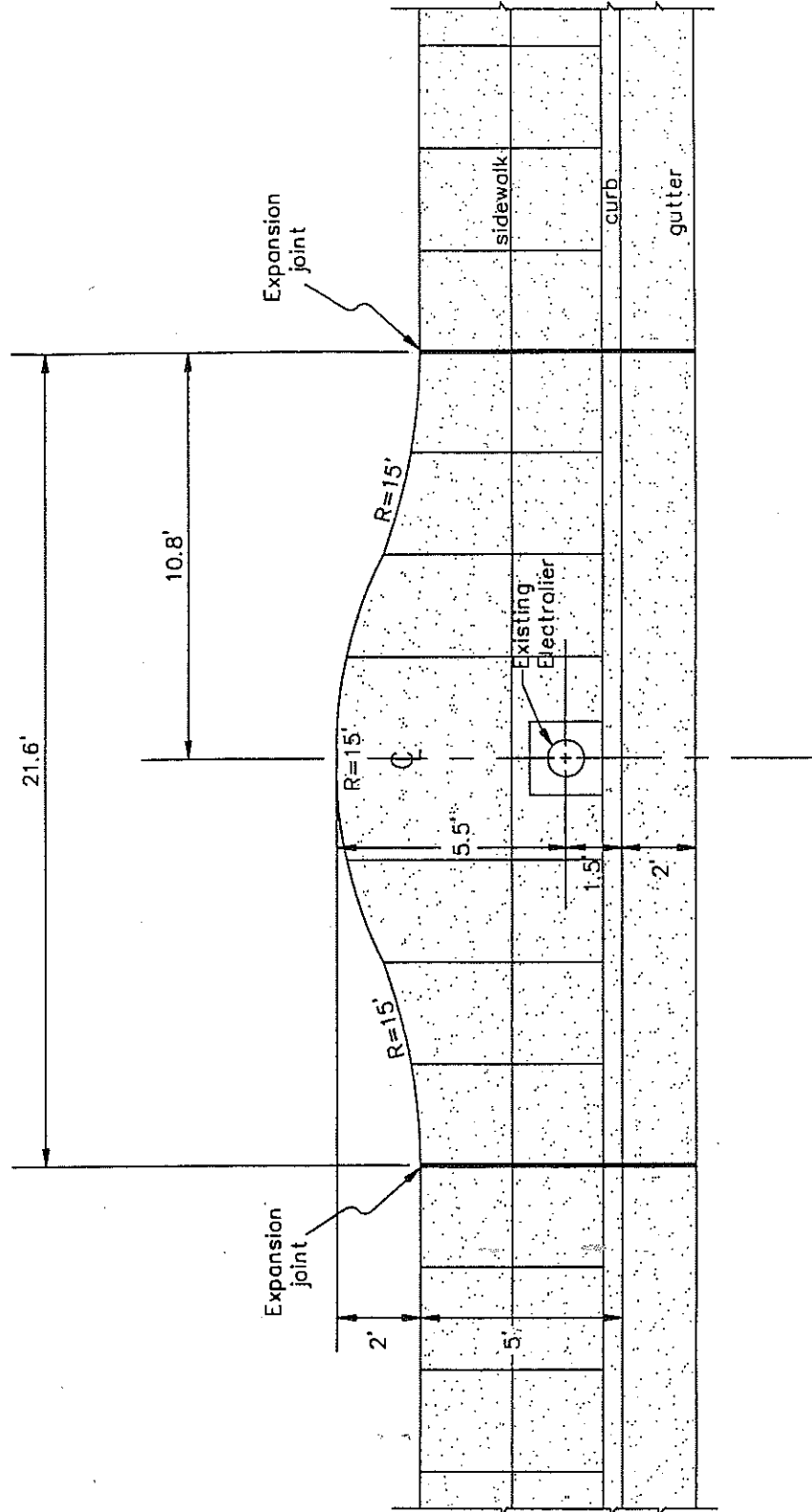

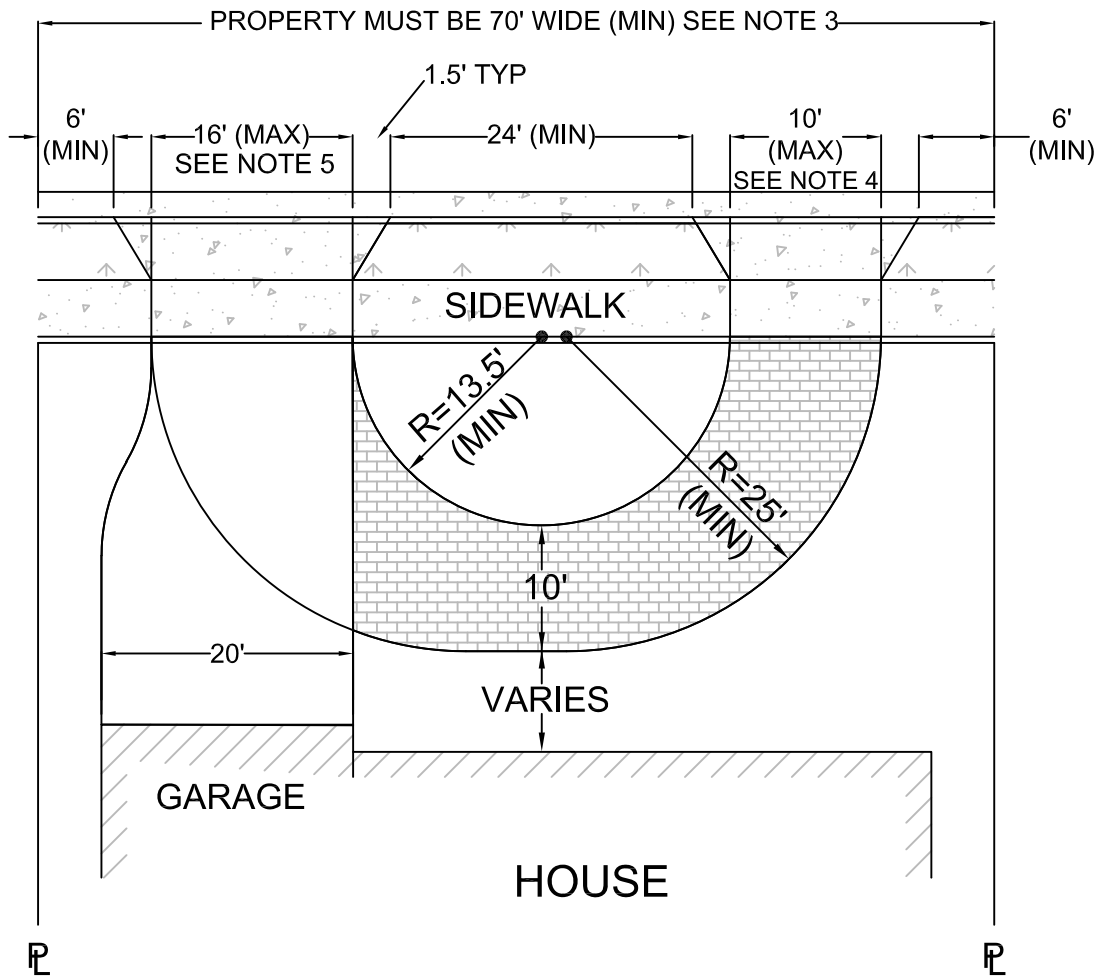

NOTES:

- 1) IN GENERAL, PUBLIC WORKS DOES NOT PERMIT CIRCULAR DRIVEWAYS IN ORDER TO REDUCE MULTIMODAL CONFLICTS AND TO PRESERVE ON-STREET PARKING. HOWEVER, EXCEPTIONS MAY BE GRANTED IF THE PROPERTY IS LOCATED ALONG ROADWAYS THAT CARRY SIGNIFICANT TRAFFIC, SUCH AS MCCLELLAN RD, N. STELLING RD, AND FOOTHILL BLVD.
- 2) THIS DETAIL ILLUSTRATES THE TYPICAL LAYOUT FOR A CIRCULAR DRIVEWAY. CIRCULAR DRIVEWAY LAYOUTS MAY BE AFFECTED, AND MAY SOMETIMES FOUND TO BE INFEASIBLE, DUE TO EXISTING SITE CONSTRAINTS INCLUDING, BUT NOT LIMITED TO, UTILITY LATERALS, STREET TREES, AND/OR UTILITY STRUCTURES PRESENT ALONG THE PROPERTY FRONTAGE.
- 3) FOR PROPERTIES LESS THAN 70' WIDE, EXCEPTIONS TO THE STANDARD DIMENSIONS MAY BE GRANTED ONLY WITH WRITTEN APPROVAL FROM THE CITY ENGINEER. AN APPLICANT MAY BE REQUIRED TO PROVIDE DRAWINGS PREPARED BY A REGISTERED CIVIL ENGINEER TO ADDRESS SITE SPECIFIC LAYOUTS AND CONDITIONS.
- 4) THE DRIVEWAY WIDTH MAY BE INCREASED TO 12' WITH WRITTEN APPROVAL FROM THE CITY ENGINEER.
- 5) THE DRIVEWAY WIDTH MAY BE INCREASED TO 18' FOR PROPERTIES GREATER THAN 70' WIDE.
- 6) THE ONSITE LAYOUT IS SUBJECT TO FRONT YARD IMPERVIOUS AREA LIMITATIONS PER CMC SECTION 19.124.030(A)(1)(e).
- 7) THE REMOVAL OF EXISTING PROTECTED AND/OR STREET TREES ARE SUBJECT TO THE CITY'S TREE REMOVAL AND REPLACEMENT REQUIREMENTS PER CMC CHAPTERS 14.12 AND 14.18.

CIRCULAR DRIVEWAY DETAIL

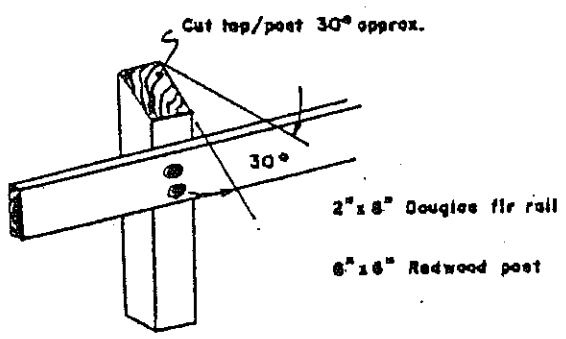
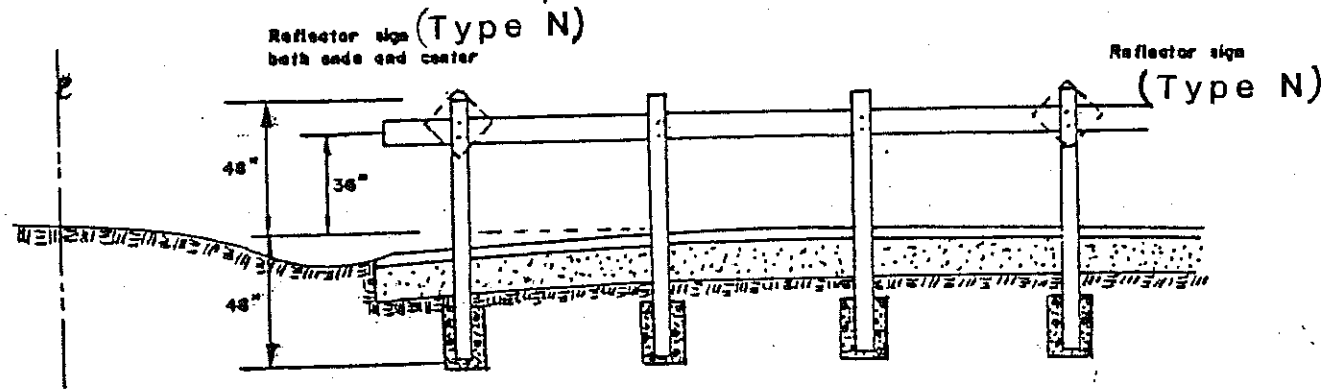
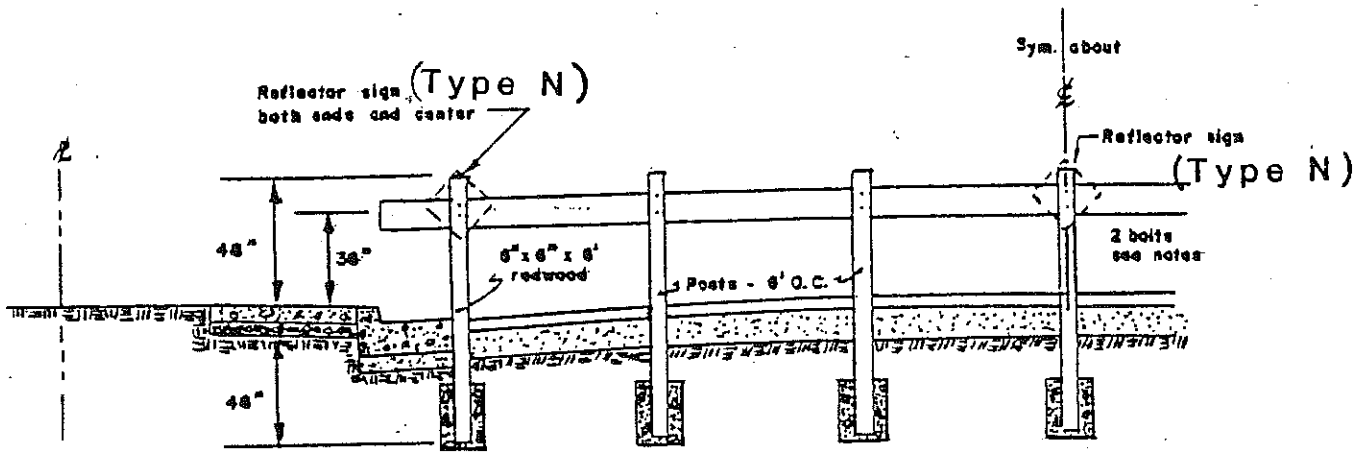

DETAIL

NOTES

1. Rails fastened to posts with 5/8" galv. machine bolts and cast-iron washer
2. Posts shall be cut as per detail
3. Place W21-R reflector signs as shown.
4. Barricades shall be primed and painted with two coats of standard exterior white paint
5. Barricades to be extended over sidewalk as required by engineer.

STANDARD STREET BARRICADE

CITY OF CUPERTINO
STANDARD DETAILS

APPROVED BY: *[Signature]* DATE: 2/10/89
CITY ENGINEER

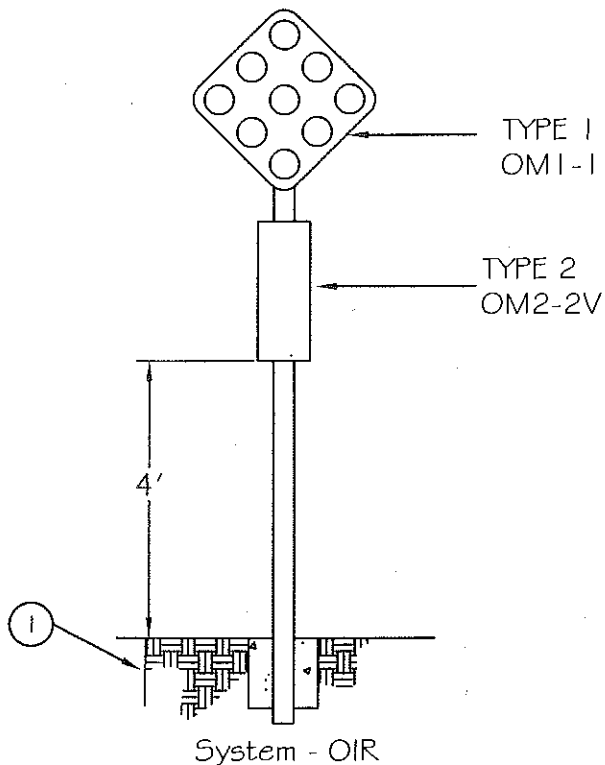

System - OIR
MARKING FOR OBJECTS IN ROADWAY

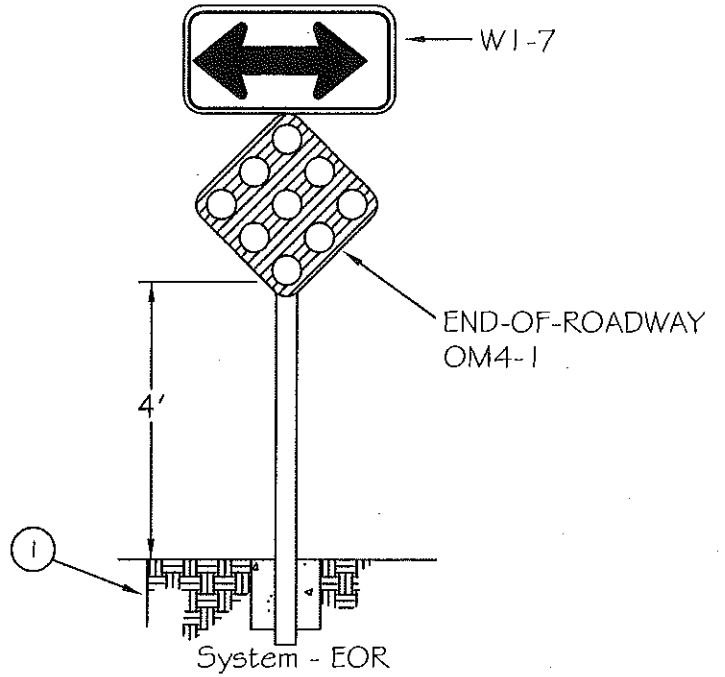

System - EOR
MARKING FOR END-OF-ROADWAY
TOP OF T-INTERSECTIONS

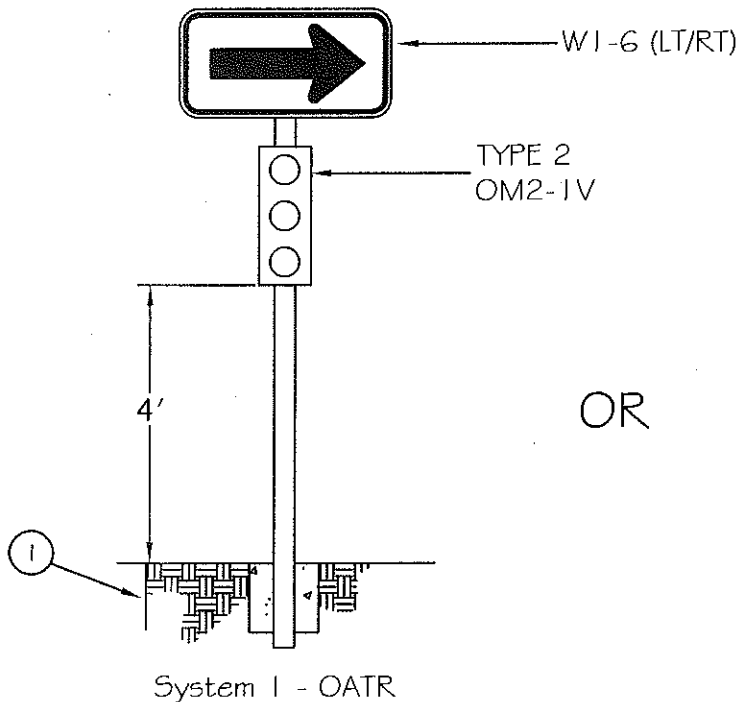

System 1 - OATR

OR

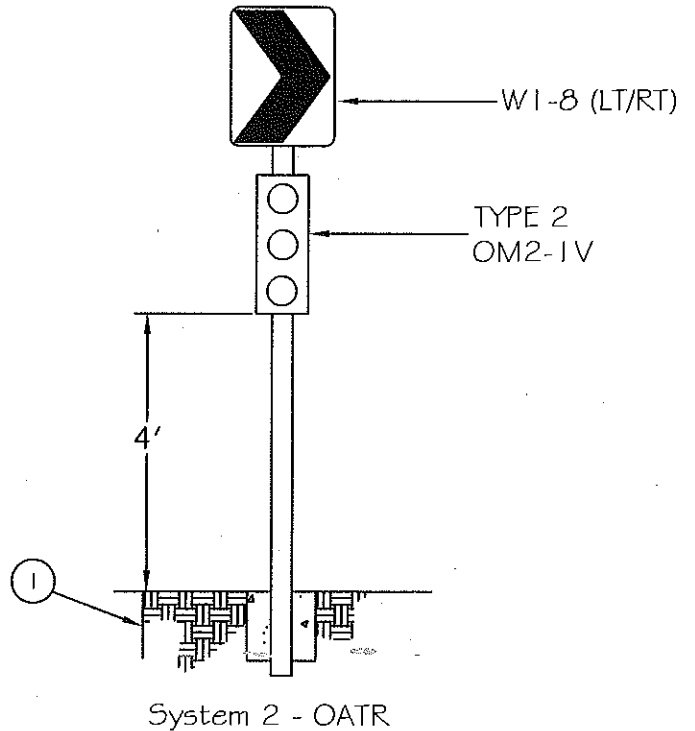

System 2 - OATR

MARKING FOR OBJECTS ADJACENT TO ROADWAY

NOTES:

① SEE CITY STANDARD DETAIL 2-20 POST & FOUNDATION.

SIGN CODING IS MUTCD 2003& CALIF SUPPLIMENT ANS SUBSEQUENTIAL REVISIONS.

OBJECT MARKING DETAIL

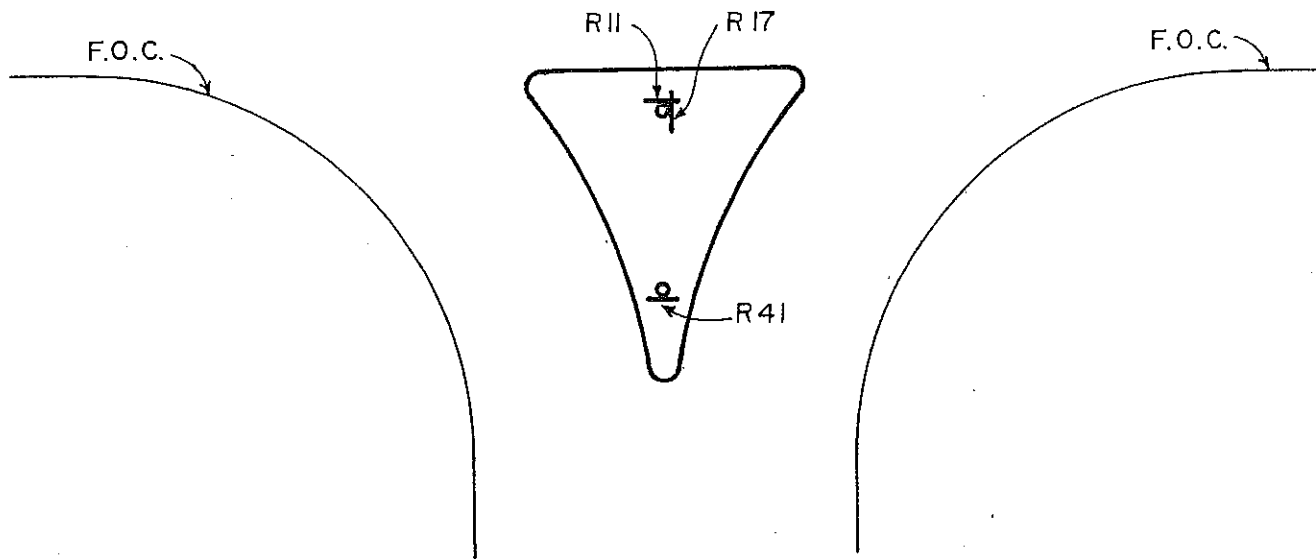

RIGHT TURN IN & OUT

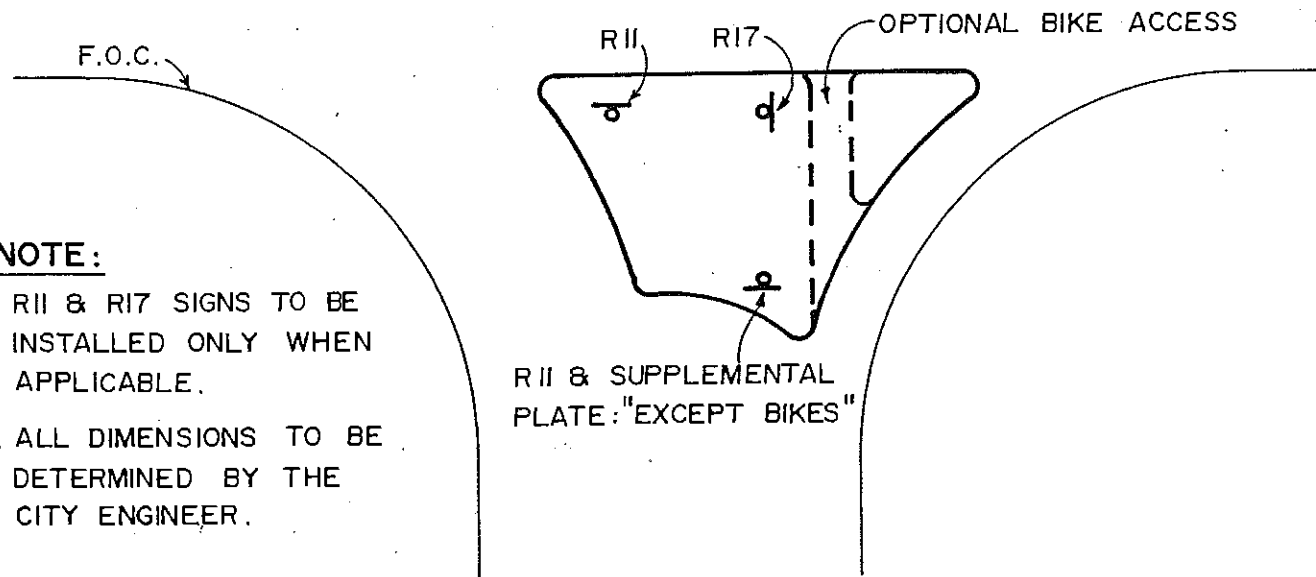

R11 & SUPPLEMENTAL PLATE: "EXCEPT BIKES"

RIGHT TURN IN

NOTE:

1. R11 & R17 SIGNS TO BE INSTALLED ONLY WHEN APPLICABLE.
2. ALL DIMENSIONS TO BE DETERMINED BY THE CITY ENGINEER.

ACCESS CONTROL ISLANDS

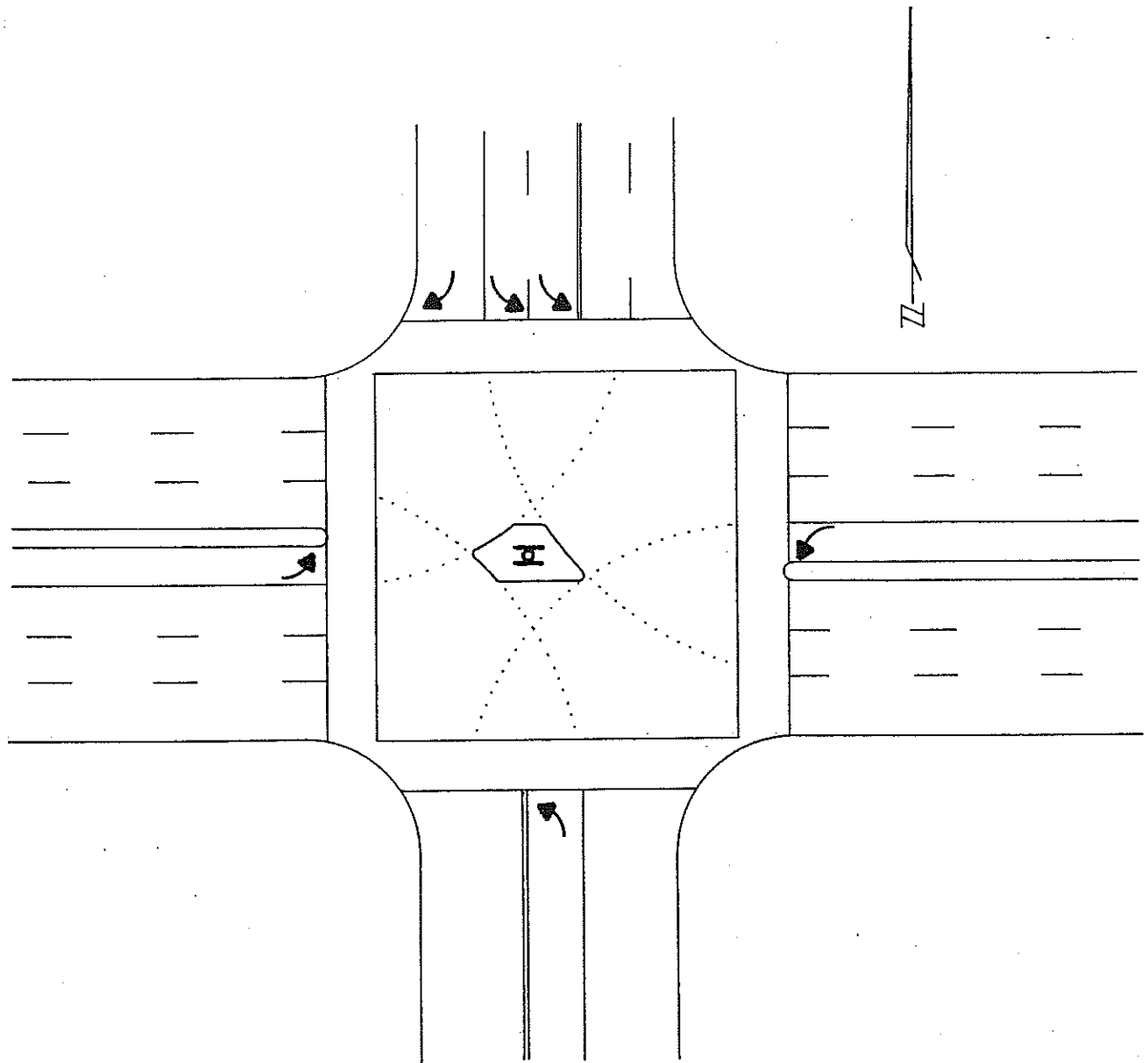

NOTE: THIS SKETCH ILLUSTRATES THROUGH MOVEMENT PROHIBITED FROM NORTH TO SOUTH, AND IS NOT TYPICAL OF ALL LOCATIONS. OTHER MOVEMENT CONTROLS REQUIRE DIFFERENT ISLAND CONFIGURATIONS.

THROUGH MOVEMENT CONTROL ISLAND

CITY OF CUPERTINO
STANDARD DETAILS

APPROVED BY:

[Signature]
CITY ENGINEER

DATE:

8-14-89

2-18

SEE CITY STD.
DETAIL 2-22
FOR STREET
NAME SIGNING

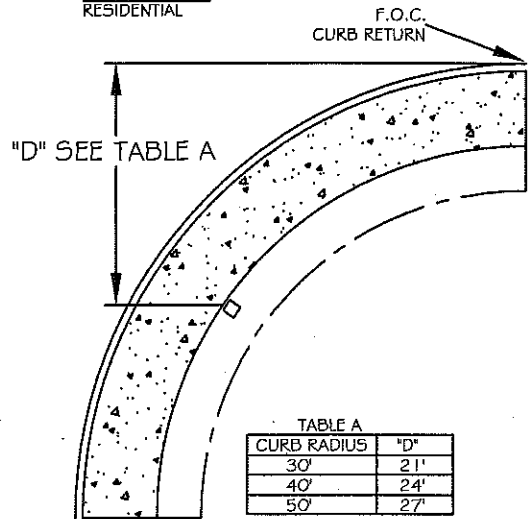
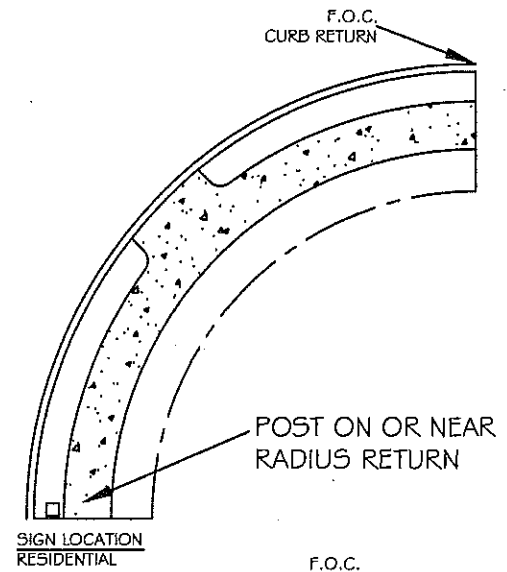
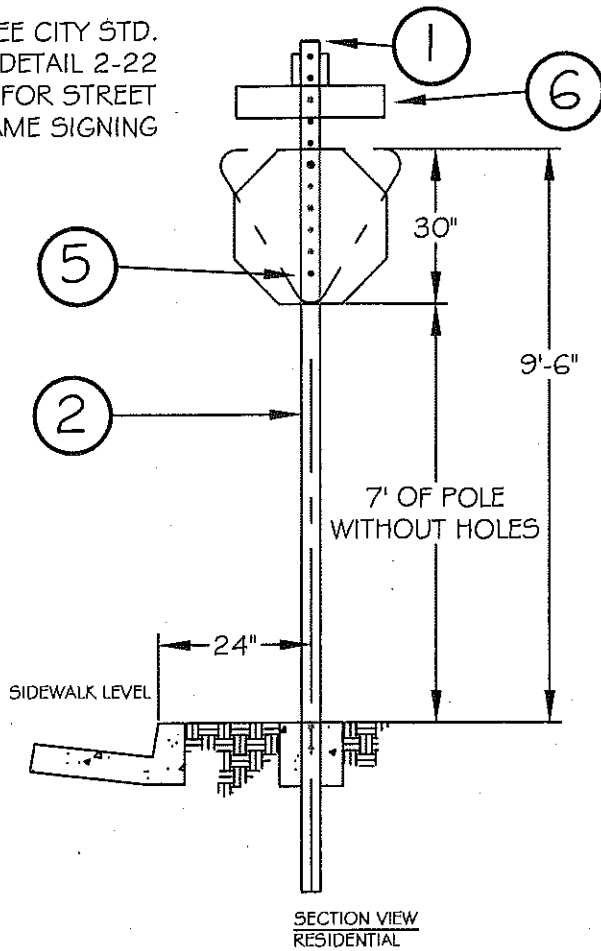
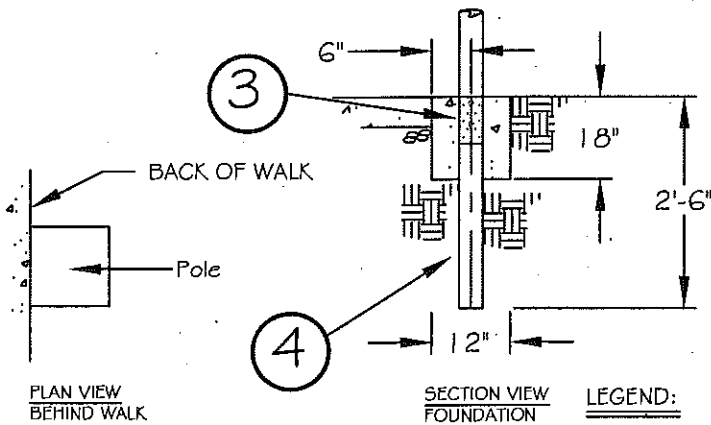

TABLE A	
CURB RADIUS	"D"
30'	21"
40'	24"
50'	27"



PLAN VIEW
BEHIND WALK

SECTION VIEW
FOUNDATION

LEGEND:

- ① Install 2" rain cap, Western Highway or equal, part No. 2UM-RC200.
- ② Two (2) inch square select punch 14 gage from Western Highway or equal, part No. 2UM-2001204-SPC (10') and 2UM-2001444-SPC (12'). Holes on all four (4) sides.
- ③ Six (6) inches of holes below grade, four (4) drive rivets one on each side, holes on all four (4) sides, and apply at least six (6) inches of tape on sleeve.
- ④ Sleeve & anchor assembly data.
Ultimate shear-safe anchor, Western Highway or equal, part No. 2UM-2250302HG4.
Must leave two (2) holes above ground. Sleeve 2 1/2" X 18", Western Highway or equal, part No. 2UM-2500182HG4.
- ⑤ Rivets shall match color of sign.
- ⑥ Larger name plate on bottom.

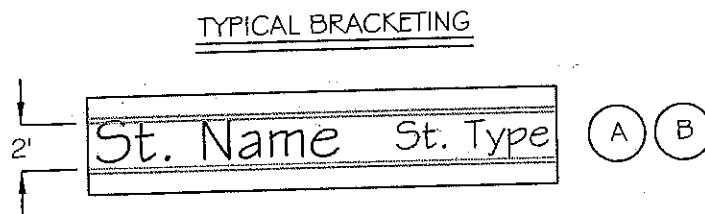
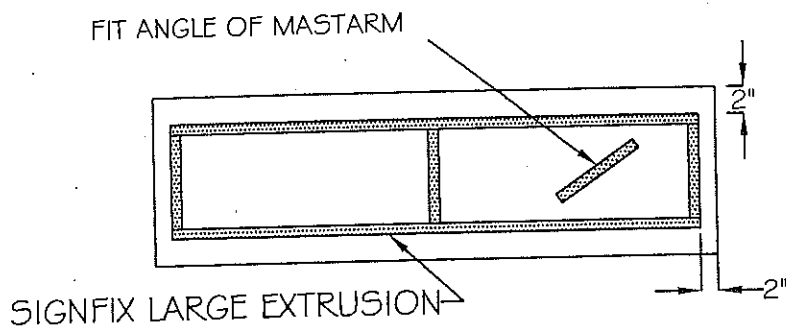
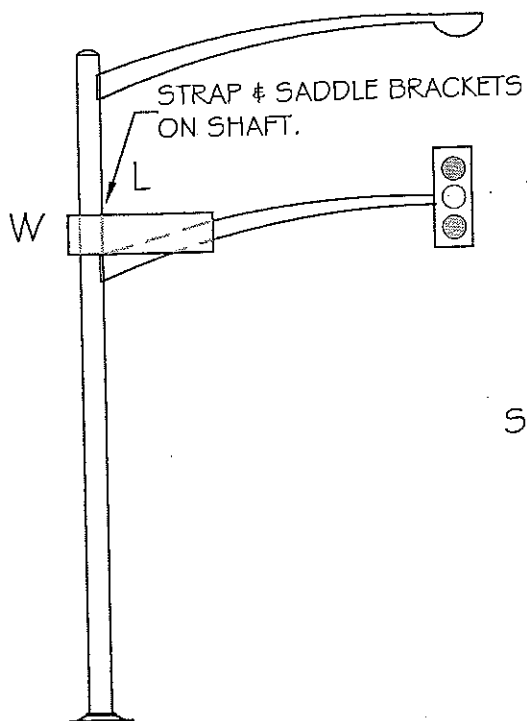

STREET NAME BLADE SHALL BE MOUNTED BETWEEN THE SHAFT AND THE MASTARM.

SIGN SIZE:
L = FIT TEXT
W = 18"

LETTERING:
STYLE "BOOKMAN BOLD"

3M DIAMOND GRADE SHEETING OR CITY APPROVED EQUAL W/ EC OVERLAY FILM

WHITE LETTERS & BORDER ON BLUE BACKGROUND

BORDER:
NO MARGIN - 1" WHITE BORDER

HARDWARE:
SIGNFIX LARGE EXTRUSION,
PART No. 5X0130
UNIVERSAL CHANNEL CLAMP
PART NO. 5X0220

- STREET NAME = 8" UC LETTERS (FIRST LETTER) REMAINING LETTERS LOWER CASE

- STREET TYPE (I.E. AVE., LN., CT.) = 5" UC (FIRST LETTER) REMAINING LETTERS LOWER CASE LETTERS CENTERED ON STREET NAME.

TYPICAL LETTERING

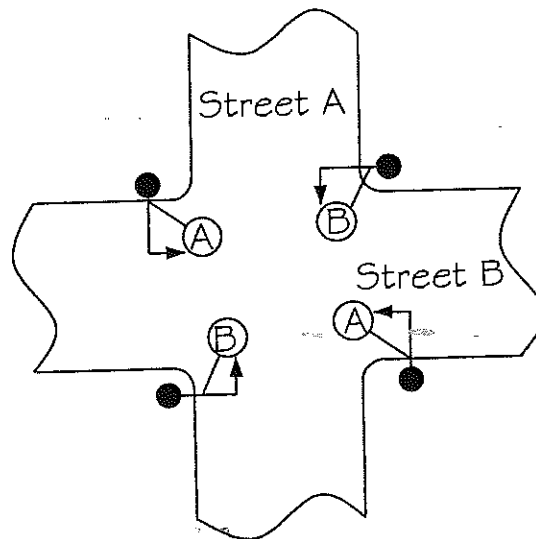

GENERAL MATERIAL & INSTALLATION FOR TRAFFIC SIGNAL POLES

TYPICAL SIGN INSTALLATION AT SIGNALIZED INTERSECTION

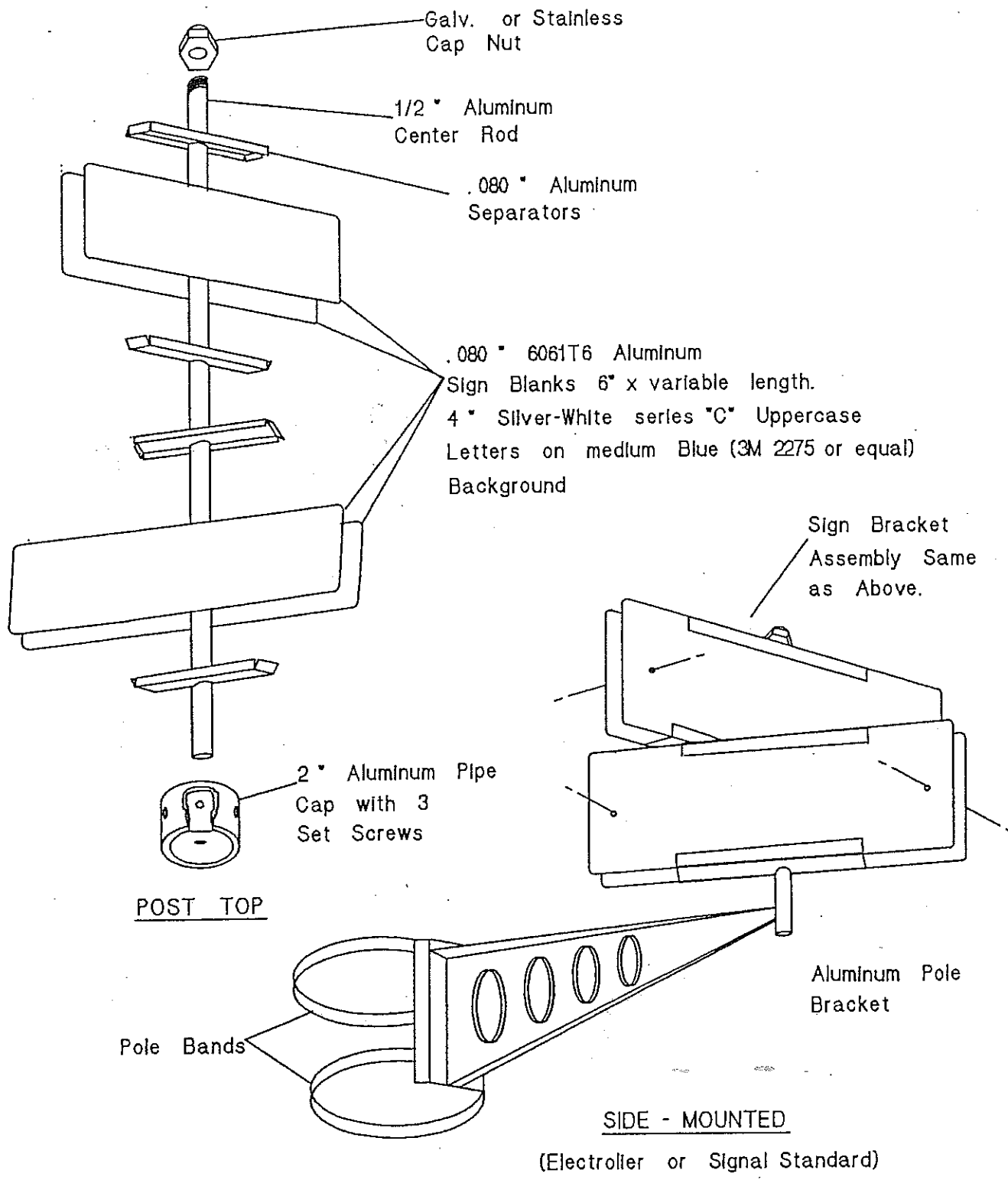

CITY OF CUPERTINO
STANDARD DETAILS

APPROVED BY: *[Signature]* DATE: 7/27/94 2 - 22
CITY ENGINEER

PUBLIC SERVICE BANNER

Hanging cable and clips
City supplied

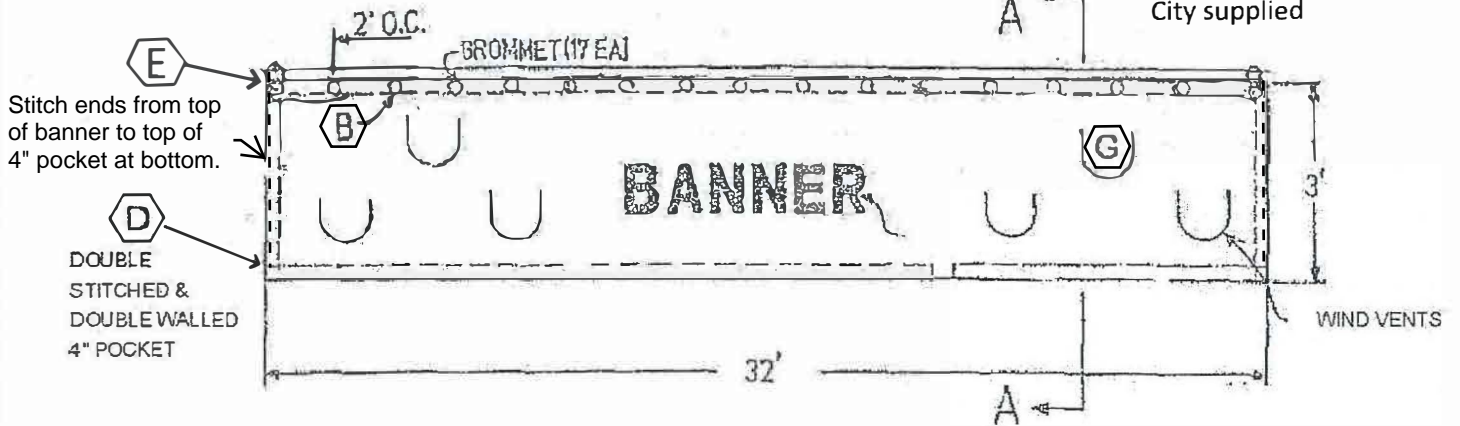

GROMMET INNER DIAMETER MUST BE 5/8"

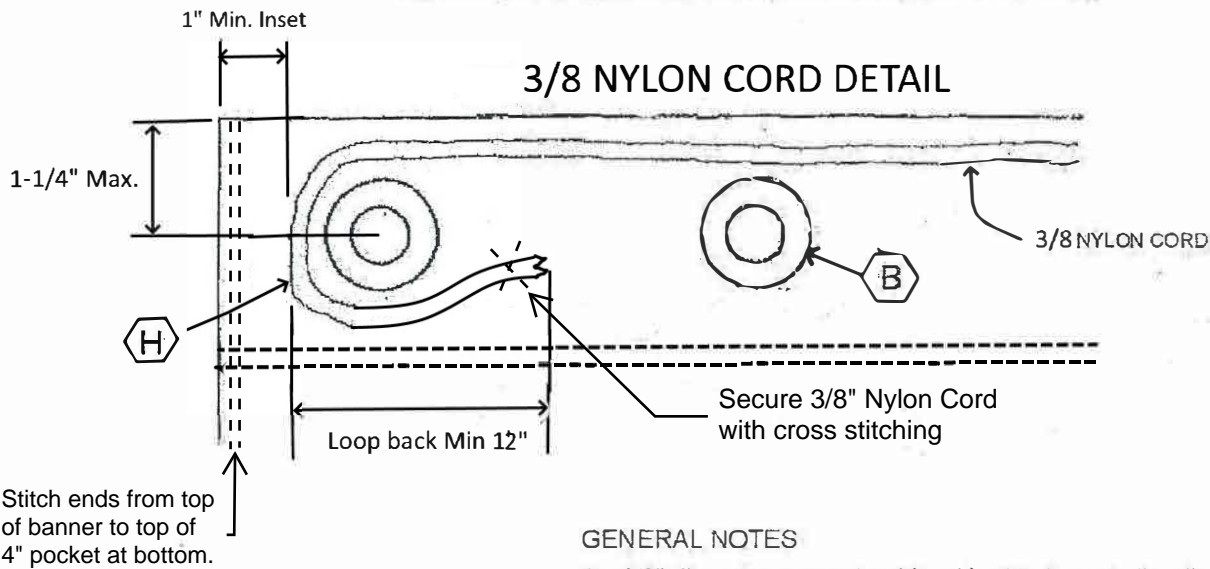

GENERAL NOTES

- A. 1/2" diameter support cable with attachment clips (by City).
- B. 5/8" interior diameter grommet >NO SUBSTITUTIONS< 2'- 0" O.C. (17 ea.)
- C. Double thickness material; 20 oz.
- D. Double walled reinforced 4" pocket double stitch with # 12 dacron thread:
- E. Reinforced grommet and cord pocket. Double stitch with #12 dacron thread pocket sized to fit cord and grommets.
- F. Minimum Letter size - 4" high. High Contrast coloring is suggested with bold font.
- G. Wind vents cut across banner - (Minimum of 9, approx. 6" x 6", evenly spaced)
- H. 3/8" Nylon Cord, 34' length, Must be looped and sewn back min 12" on each end. (see detail H above) Cordage must loop around end grommets and secured with stitching at each end

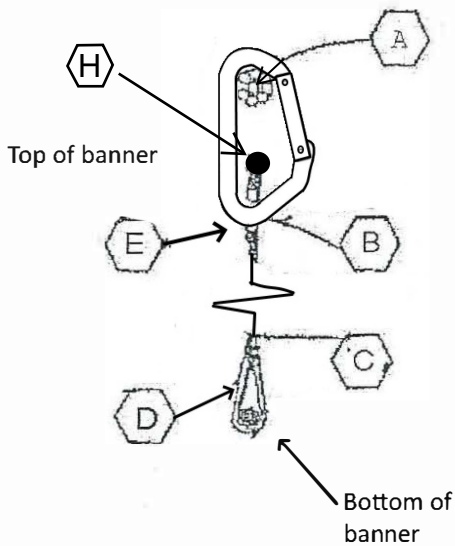

SECTION A - A

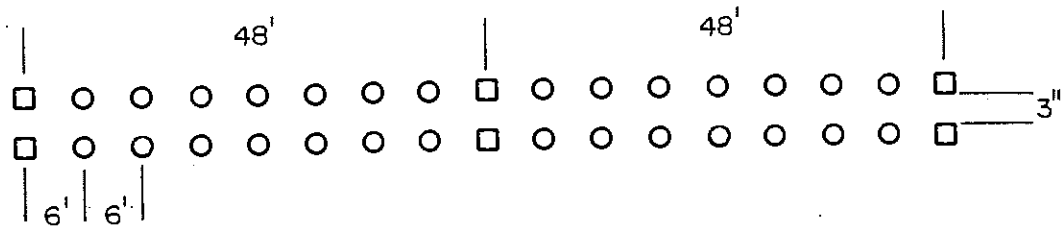

DETAIL 23C

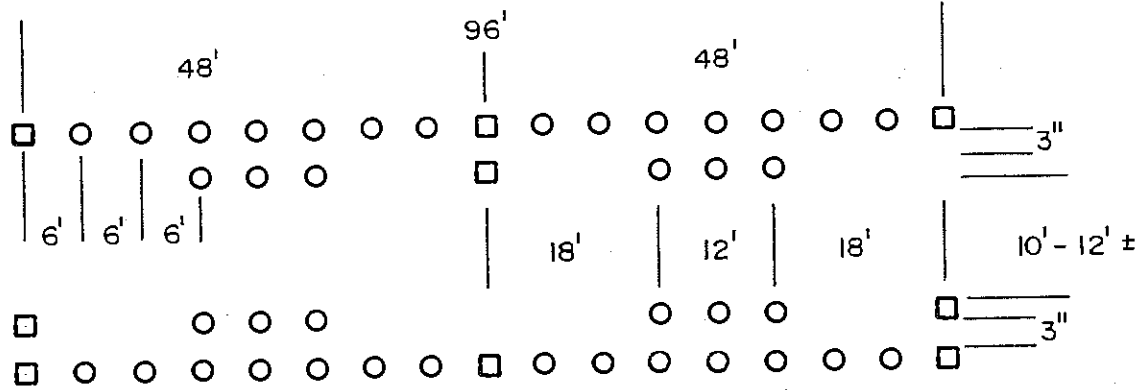

DETAIL 33C

LEGEND

- TWO-WAY YELLOW REFLECTIVE MARKER
- NON-REFLECTIVE YELLOW MARKER

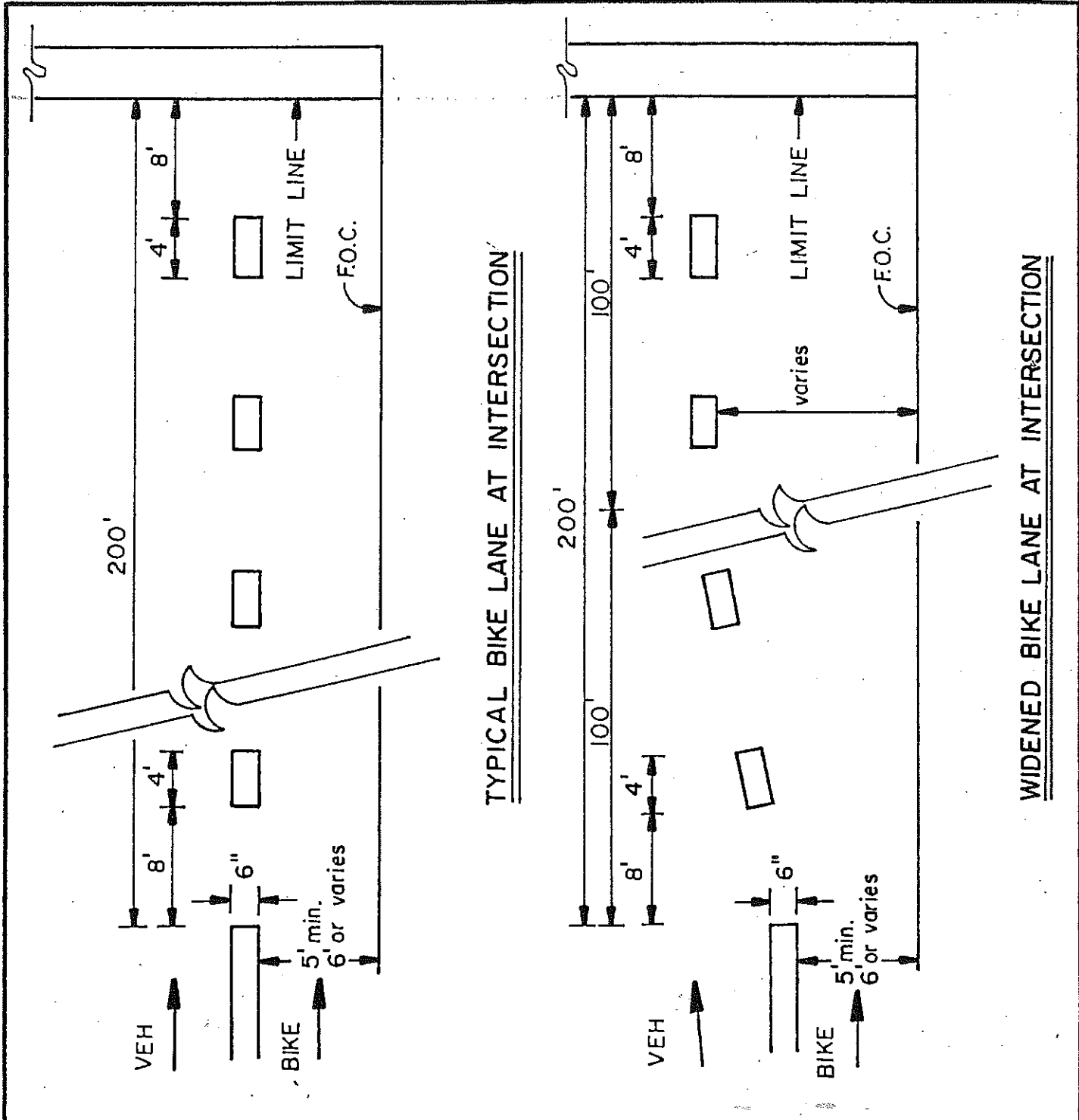

TYPICAL BIKE LANE AT INTERSECTION

WIDENED BIKE LANE AT INTERSECTION

DETAIL 39AC
BIKE LANE DETAILS

Angle (Degrees)	Stall Width	Stall Depth		Curb Length "C"	Aisle Width "D"	
		"A"	"B"		One-Way	Two-Way
0	8.0	N/A	N/A	N/A	12.0	20.0
30	8.5	12.7	16.4	17.0	14.0	22.0
35	8.5	13.8	17.3	14.8	14.0	22.0
40	8.5	14.8	18.1	13.2	14.5	22.0
45	8.5	15.7	18.7	12.0	15.0	22.0
50	8.5	16.5	19.3	11.1	15.0	22.0
55	8.5	17.2	19.6	10.4	15.5	22.0
60	8.5	17.7	19.8	9.8	16.0	22.0
65	8.5	18.1	19.9	9.4	17.5	23.0
70	8.5	18.4	19.8	9.0	19.0	24.0
75	8.5	18.5	19.6	8.8	20.0	24.0
80	8.5	18.5	19.2	8.6	20.0	24.0
85	8.5	18.3	18.7	8.5	20.0	24.0
90	8.5	18.0	18.0	8.5	20.0	24.0

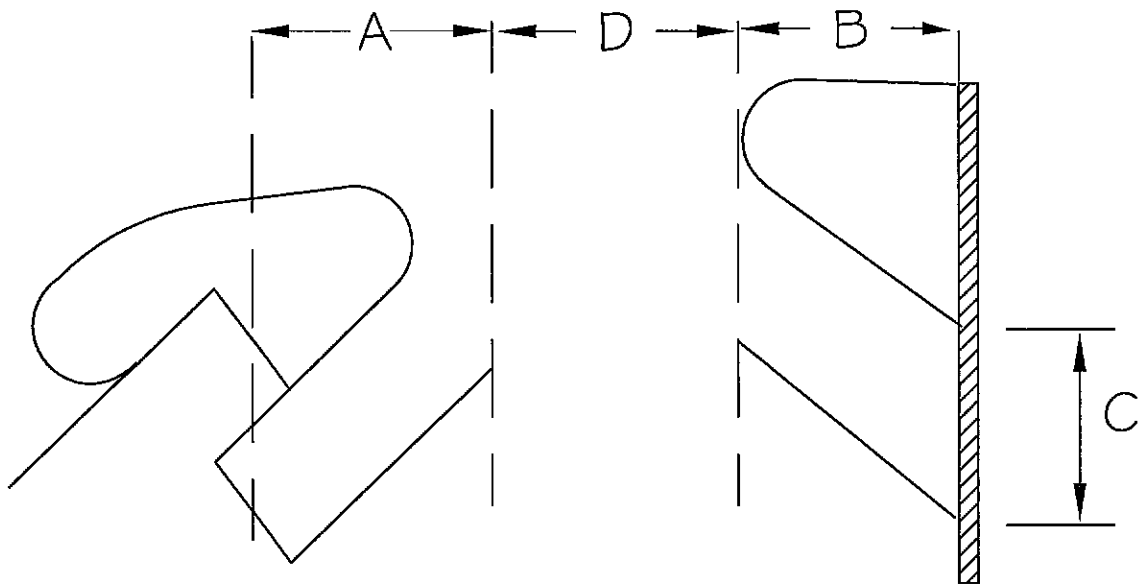

PARKING AISLES

TWO-WAY AISLE

STALL WIDTH 8.00 Feet * TWO-WAY AISLE COMPACT VEHICLES ONLY								STALL WIDTH 8.50 Feet * TWO-WAY AISLE COMPACT VEHICLES ONLY							
ANGLE DEGREE	STALL DEPTH		AISLE WIDTH		DEPTH	CURB @WALL LENGTH			STALL DEPTH	AISLE WIDTH		DEPTH	CURB @WALL LENGTH		
	"A"	"B"	"C"	"D"	A+B+A	A+B+C	G+B+C	"A"		"B"	"C"	"D"	A+B+A	A+B+C	G+B+C
0	8.0	18.0	8.0	18.0	N/A	N/A	N/A	8.0	18.0	8.0	18.0	N/A	N/A	N/A	
30	11.2	18.0	14.7	16.0	40.4	43.9	47.4	11.4	18.0	15.1	17.0	40.9	44.5	48.2	
35	12.2	18.0	15.4	13.9	42.3	45.6	48.9	12.4	18.0	15.9	14.8	42.7	46.2	49.7	
40	13.0	18.0	16.1	12.4	44.1	47.1	50.2	13.2	18.0	16.5	13.2	44.4	47.7	50.9	
45	13.8	18.5	16.6	11.3	46.1	48.9	51.7	14.0	18.0	17.0	12.0	45.9	48.9	51.9	
50	14.4	19.0	17.0	10.4	47.9	50.5	53.0	14.6	18.0	17.3	11.1	47.2	49.9	52.7	
55	15.0	19.5	17.3	9.8	49.5	51.8	54.1	15.1	18.5	17.6	10.4	48.8	51.2	53.6	
60	15.4	20.0	17.4	9.2	50.8	52.8	54.8	15.5	19.0	17.7	9.8	50.1	52.2	54.3	
65	15.7	20.5	17.4	8.8	52.0	53.7	55.4	15.8	19.5	17.6	9.4	51.2	53.0	54.8	
70	15.9	21.0	17.3	8.5	52.9	54.2	55.6	16.0	20.0	17.5	9.0	52.0	53.5	54.9	
75	16.0	21.5	17.0	8.3	53.5	54.5	55.6	16.1	20.5	17.2	8.8	52.6	53.7	54.8	
80	16.0	22.0	16.7	8.1	53.9	54.6	55.3	16.0	21.0	16.7	8.6	53.0	53.7	54.5	
85	15.8	22.5	16.1	8.0	54.1	54.4	54.8	15.8	21.5	16.2	8.5	53.1	53.5	53.9	
90	15.5	23.0	15.5	8.0	54.0	54.0	54.0	15.5	22.0	15.5	8.5	53.0	53.0	53.0	

STALL WIDTH 9.00 Feet * TWO-WAY AISLE								STALL WIDTH 9.50 Feet * TWO-WAY AISLE							
ANGLE DEGREE	STALL DEPTH		AISLE WIDTH		DEPTH	CURB @WALL LENGTH			STALL DEPTH	AISLE WIDTH		DEPTH	CURB @WALL LENGTH		
	"A"	"B"	"C"	"D"	A+B+A	A+B+C	G+B+C	"A"		"B"	"C"	"D"	A+B+A	A+B+C	G+B+C
0	8.0	18.0	8.0	22.0	N/A	N/A	N/A	8.0	18.0	8.0	22.0	N/A	N/A	N/A	
30	12.9	18.0	16.8	18.0	43.8	47.7	51.6	13.1	18.0	17.2	19.0	44.2	48.3	52.5	
35	14.0	18.0	17.7	15.7	46.0	49.7	53.4	14.2	18.0	18.1	16.6	46.4	50.3	54.2	
40	15.0	18.0	18.5	14.0	48.0	51.5	54.9	15.2	18.0	18.8	14.8	48.4	52.1	55.7	
45	15.9	18.0	19.1	12.7	49.8	53.0	56.2	16.1	18.0	19.4	13.4	50.2	53.5	56.9	
50	16.7	18.0	19.6	11.7	51.4	54.3	57.1	16.8	18.0	19.9	12.4	51.7	54.7	57.8	
55	17.3	18.0	19.9	11.0	52.7	55.2	57.8	17.5	18.0	20.2	11.6	52.9	55.7	58.4	
60	17.8	19.0	20.1	10.4	54.7	56.9	59.2	18.0	18.0	20.3	11.0	53.9	56.3	58.7	
65	18.2	20.0	20.1	9.9	56.4	58.3	60.2	18.3	19.0	20.3	10.5	55.6	57.6	59.7	
70	18.5	21.0	20.0	9.6	57.9	59.4	61.0	18.5	20.0	20.2	10.1	57.1	58.7	60.3	
75	18.6	22.0	19.7	9.3	59.1	60.3	61.4	18.6	21.0	19.8	9.8	58.2	59.5	60.7	
80	18.5	23.0	19.3	9.1	60.0	60.8	61.6	18.6	22.0	19.4	9.6	59.1	59.9	60.8	
85	18.3	24.0	18.7	9.0	60.6	61.0	61.4	18.3	23.0	18.8	9.5	59.7	60.1	60.5	
90	18.0	25.0	18.0	9.0	61.0	61.0	61.0	18.0	24.0	18.0	9.5	60.0	60.0	60.0	

STALL WIDTH 10.00 Feet * TWO-WAY AISLE								
ANGLE DEGREE	STALL DEPTH		AISLE WIDTH		DEPTH	CURB @WALL LENGTH		
	"A"	"B"	"C"	"D"	A+B+A	A+B+C	G+B+C	
0	8	18.0	8	48(2)	N/A	N/A	N/A	
30	13.3	18.0	17.7	20.0	44.7	49.0	53.3	
35	14.4	18.0	18.5	17.4	46.8	50.9	55.0	
40	15.4	18.0	19.2	15.6	48.8	52.6	56.5	
45	16.3	18.0	19.8	14.1	50.5	54.1	57.6	
50	17.0	18.0	20.2	13.1	52.0	55.2	58.4	
55	17.6	18.0	20.5	12.2	53.2	56.1	59.0	
60	18.1	18.0	20.6	11.5	54.2	56.7	59.2	
65	18.4	18.0	20.5	11.0	54.9	57.0	59.1	
70	18.6	19.0	20.3	10.6	56.2	58.0	59.7	
75	18.7	20.0	20.0	10.4	57.4	58.7	59.9	
80	18.6	21.0	19.5	10.2	58.2	59.1	59.9	
85	18.4	22.0	18.8	10.0	58.7	59.2	59.6	
90	18.0	23.0	18.0	10.0	59.0	59.0	59.0	

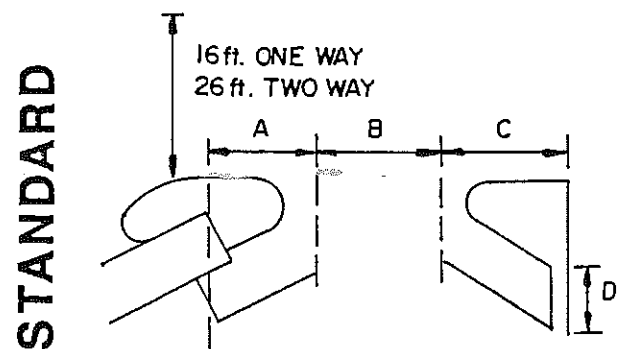

COMPACT

STANDARD

ONE-WAY AISLE

TWO-WAY AISLE

STALL WIDTH 9.00 Feet * ONE-WAY AISLE SINGLE HANDICAP STALL * SPACE ONE SIDE								STALL WIDTH 9.00 Feet * TWO-WAY AISLE DOUBLE HANDICAP STALL * SPACE CENTERED						
ANGLE DEGREE	STALL AISLE DEPTH CURB			CURB LENGTH "D"	A+B+A A+B+C C+B+C			A	STALL AISLE DEPTH CURB			A+B+A A+B+C C+B+C		
	DEPTH "A"	WIDTH "B"	@WALL "C"		A+B+A	A+B+C	C+B+C		DEPTH "A"	WIDTH "B"	@WALL "C"	DEPTH "D"	A+B+A	A+B+C
0	8.0	10.0	8.0	48(2)	N/A	N/A	N/A	8.0	18.0	8.0	48(2)	N/A	N/A	N/A
30	12.9	10.0	16.8	28.0	35.8	39.7	43.6	12.9	18.0	16.8	46.0	43.8	47.7	51.6
35	14.0	10.0	17.7	24.4	38.0	41.7	45.4	14.0	18.0	17.7	40.1	46.0	49.7	53.4
40	15.0	10.0	18.5	21.8	40.0	43.5	46.9	15.0	18.0	18.5	35.8	48.0	51.5	54.9
45	15.9	11.5	19.1	19.8	43.3	46.5	49.7	15.9	18.0	19.1	32.5	49.8	53.0	56.2
50	16.7	13.0	19.6	18.3	46.4	49.3	52.1	16.7	18.0	19.6	30.0	51.4	54.3	57.1
55	17.3	14.5	19.9	17.1	49.2	51.7	54.3	17.3	18.0	19.9	28.1	52.7	55.2	57.8
60	17.8	16.0	20.1	16.2	51.7	53.9	56.2	17.8	19.0	20.1	26.6	54.7	56.9	59.2
65	18.2	17.5	20.1	15.4	53.9	55.8	57.7	18.2	20.0	20.1	25.4	56.4	58.3	60.2
70	18.5	19.0	20.0	14.9	55.9	57.4	59.0	18.5	21.0	20.0	24.5	57.9	59.4	61.0
75	18.6	20.5	19.7	14.5	57.6	58.8	59.9	18.6	22.0	19.7	23.8	59.1	60.3	61.4
80	18.5	22.0	19.3	14.2	59.0	59.8	60.6	18.5	23.0	19.3	23.4	60.0	60.8	61.6
85	18.3	23.5	18.7	14.1	60.1	60.5	60.9	18.3	24.0	18.7	23.1	60.6	61.0	61.4
90	N/A	N/A	N/A	N/A	N/A	N/A	N/A	18.0	25.0	18.0	23.0	61.0	61.0	61.0

STALL WIDTH 8.67 Feet * ONE-WAY AISLE								STALL WIDTH 8.67 Feet * TWO-WAY AISLE						
ANGLE DEGREE	STALL AISLE DEPTH CURB			CURB LENGTH "D"	A+B+A A+B+C C+B+C			A	STALL AISLE DEPTH CURB			A+B+A A+B+C C+B+C		
	DEPTH "A"	WIDTH "B"	@WALL "C"		A+B+A	A+B+C	C+B+C		DEPTH "A"	WIDTH "B"	@WALL "C"	DEPTH "D"	A+B+A	A+B+C
0	8.0	10.0	8.0	48(2)	N/A	N/A	N/A	8	18.0	8	48(2)	N/A	N/A	N/A
30	12.8	10.0	16.5	17.3	35.5	39.3	43.0	12.8	18.0	16.5	17.3	43.5	47.3	51.0
35	13.9	10.0	17.4	15.1	37.7	41.3	44.8	13.9	18.0	17.4	15.1	45.7	49.3	52.8
40	14.9	10.5	18.2	13.5	40.3	43.6	46.9	14.9	18.0	18.2	13.5	47.8	51.1	54.4
45	15.8	12.0	18.9	12.3	43.6	46.6	49.7	15.8	18.0	18.9	12.3	49.6	52.6	55.7
50	16.6	13.5	19.4	11.3	46.6	49.4	52.2	16.6	18.0	19.4	11.3	51.1	53.9	56.7
55	17.2	15.0	19.7	10.6	49.5	51.9	54.4	17.2	18.5	19.7	10.6	53.0	55.4	57.9
60	17.8	16.5	19.9	10.0	52.0	54.2	56.3	17.8	19.5	19.9	10.0	55.0	57.2	59.3
65	18.1	18.0	20.0	9.6	54.3	56.1	58.0	18.1	20.5	20.0	9.6	56.8	58.6	60.5
70	18.4	19.5	19.9	9.2	56.3	57.8	59.3	18.4	21.5	19.9	9.2	58.3	59.8	61.3
75	18.5	21.0	19.6	9.0	58.0	59.1	60.3	18.5	22.5	19.6	9.0	59.5	60.6	61.8
80	18.5	22.5	19.2	8.8	59.5	60.2	61.0	18.5	23.5	19.2	8.8	60.5	61.2	62.0
85	18.3	24.0	18.7	8.7	60.6	61.0	61.4	18.3	24.5	18.7	8.7	61.1	61.5	61.9
90	N/A	N/A	N/A	N/A	N/A	N/A	N/A	18.0	25.5	18.0	8.7	61.5	61.5	61.5

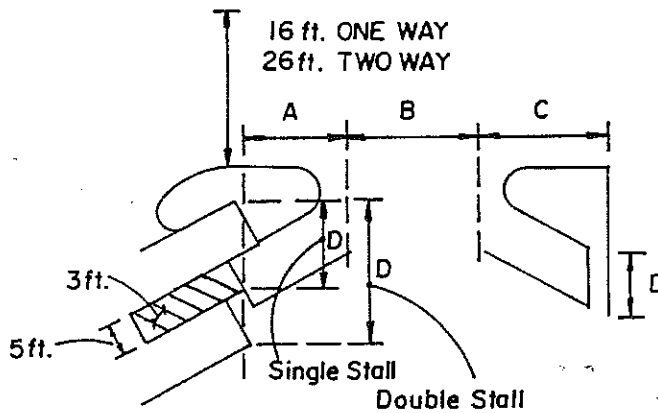

HANDICAP

INDUSTRIAL

HANDICAP

INDUSTRIAL

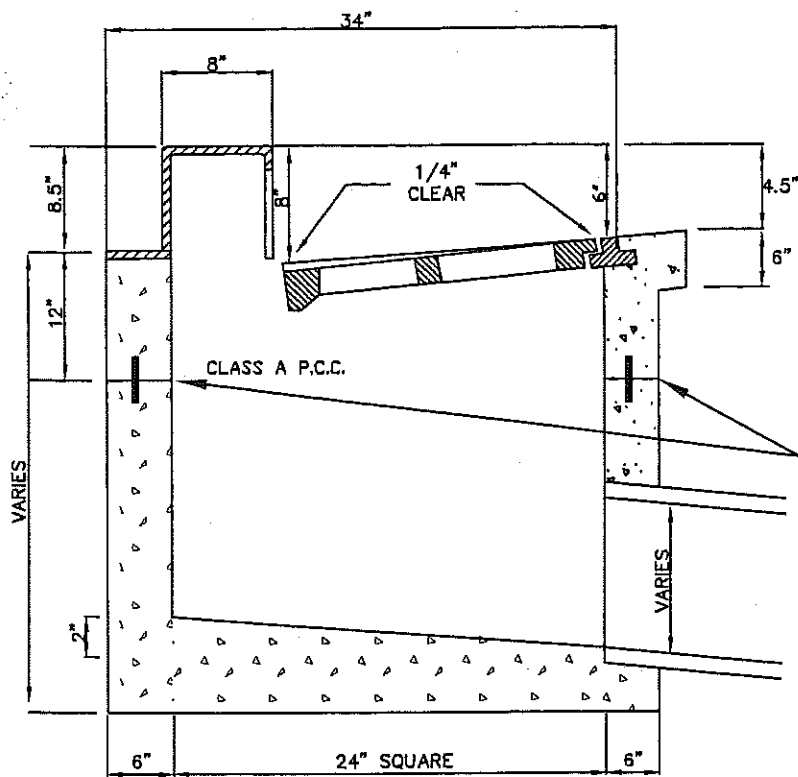

SECTION A-A Showing Concrete Box

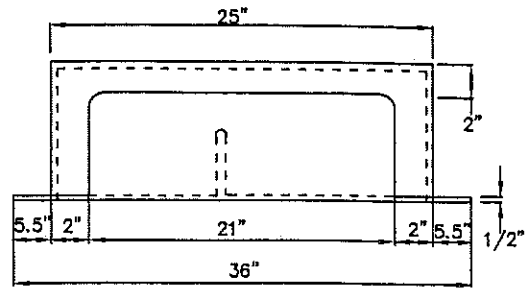

VIEW B-B

Note: Const. jt. permitted when catch basin top is reconstructed. Place #4 x 12" dowels at each const. jt. Drill holes, blow clean and set dowels in epoxy.

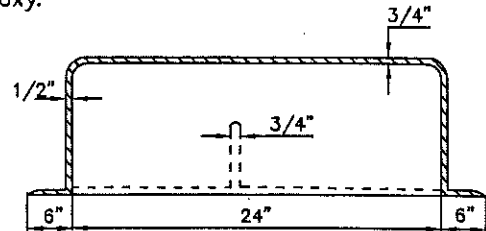

SECTION CURB CASTING

NOTE: Frame dimensions may vary with the approval of the City Engineer.

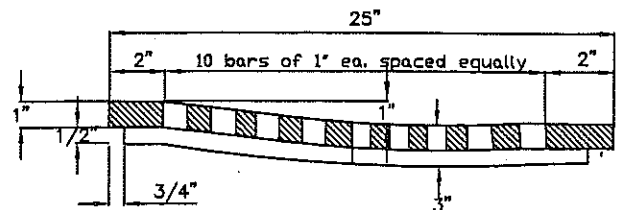
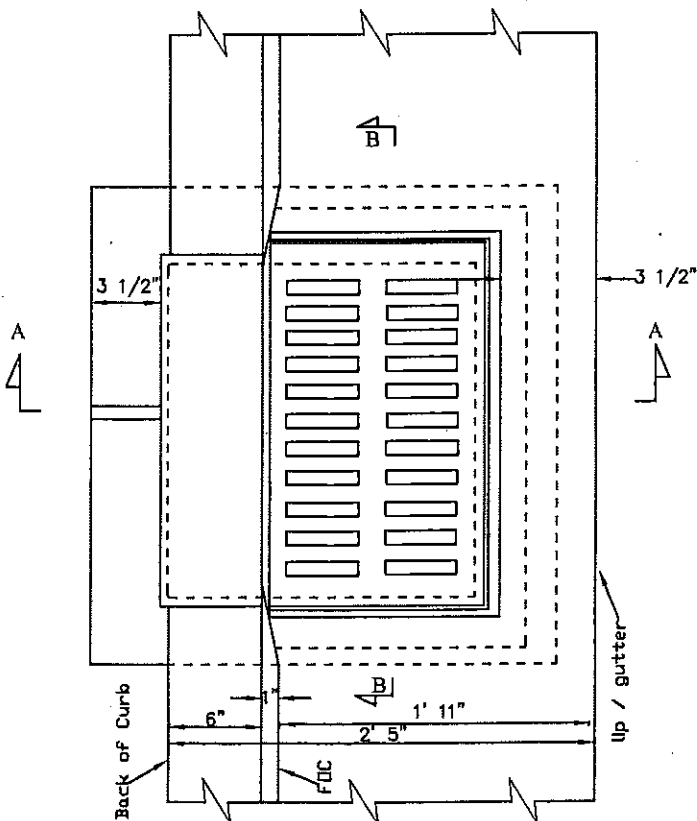

SECTION B-B

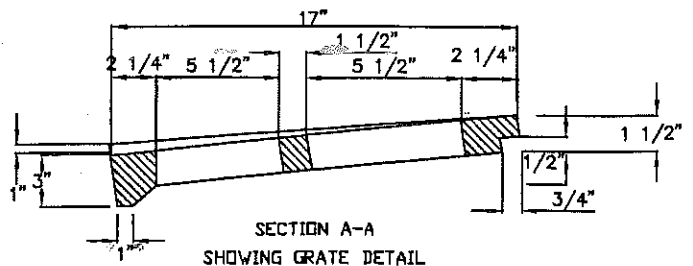

SECTION A-A SHOWING GRATE DETAIL

STANDARD DROP INLET - CURB OPENING

CITY OF CUPERTINO
STANDARD DETAILS

APPROVED BY: *Rachel*
City Engineer

DATE: 6.10.07

3-2

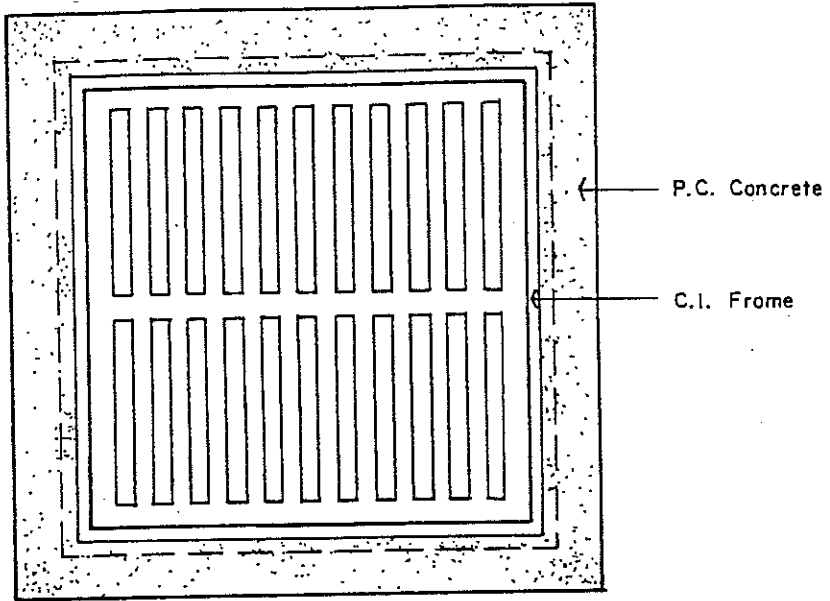

PLAN

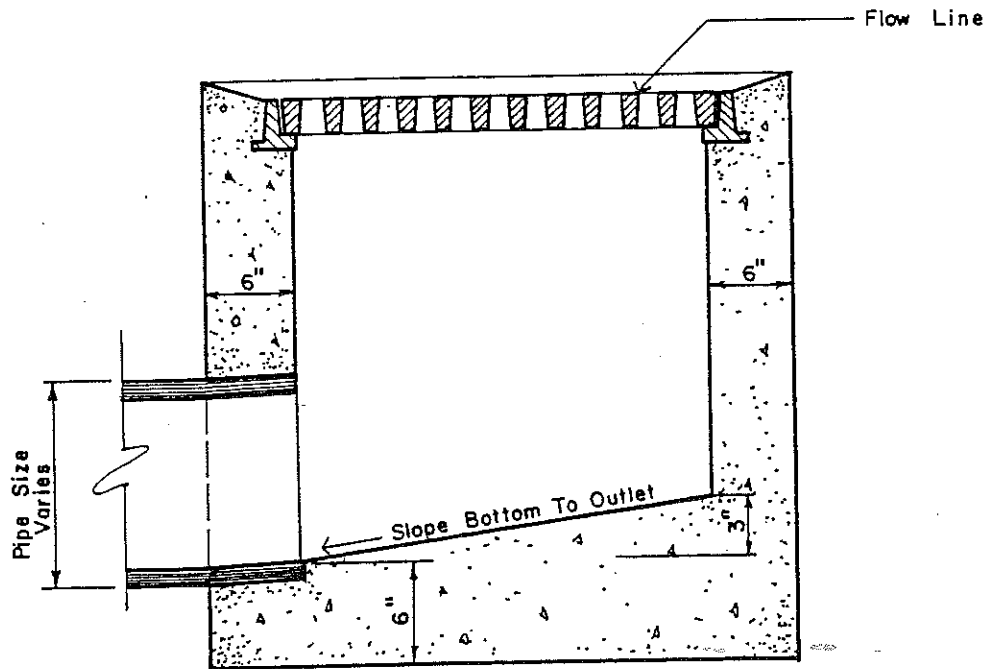

SECTION

STANDARD 24" FLAT GRATE DROP INLET

CITY OF CUPERTINO
STANDARD DETAILS

APPROVED BY :

[Signature]
CITY ENGINEER

DATE :

2/10/89

4 - $\frac{5}{8}$ " ϕ x 7" Anchor bolts

2" x 12" Redwood cover

2" x 6" cross-bracing

Ditch flow line at box openings

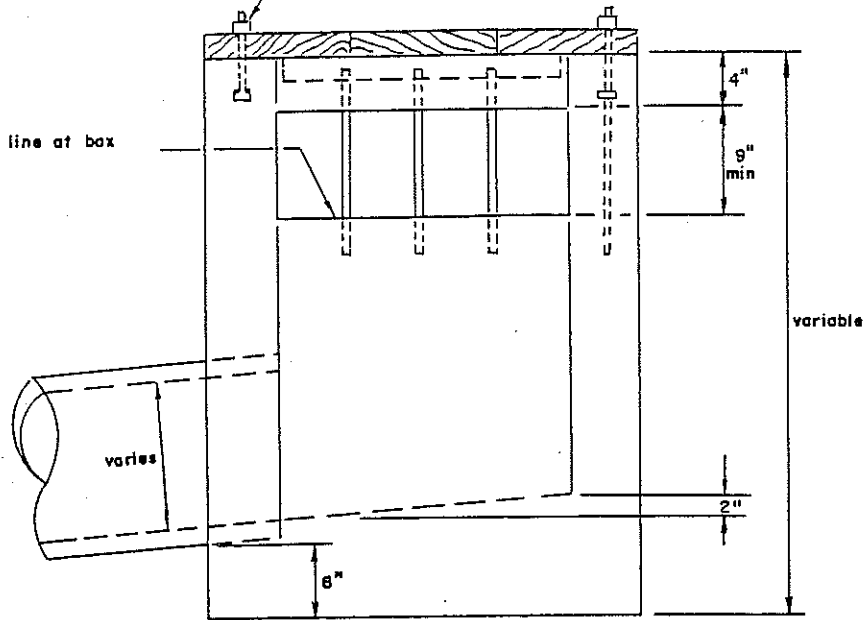

SIDE ELEVATION

$\frac{1}{2}$ " ϕ bars - 3" anchorage

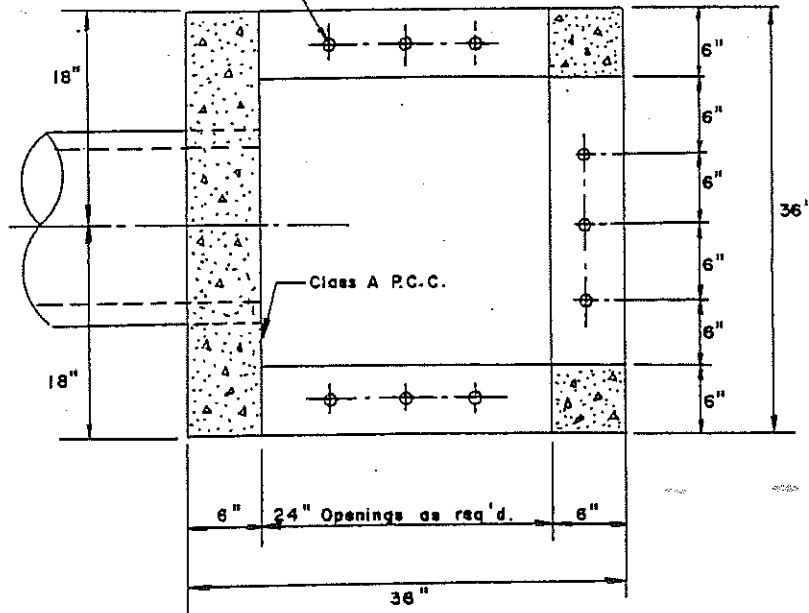

SECTION THROUGH OPENING

FIELD INLET - SIDE OPENING

CITY OF CUPERTINO
STANDARD DETAILS

APPROVED BY :

[Signature]
CITY ENGINEER

DATE :

2/10/59

3-8

CONCENTRIC MANHOLE

8" to 33" PIPE

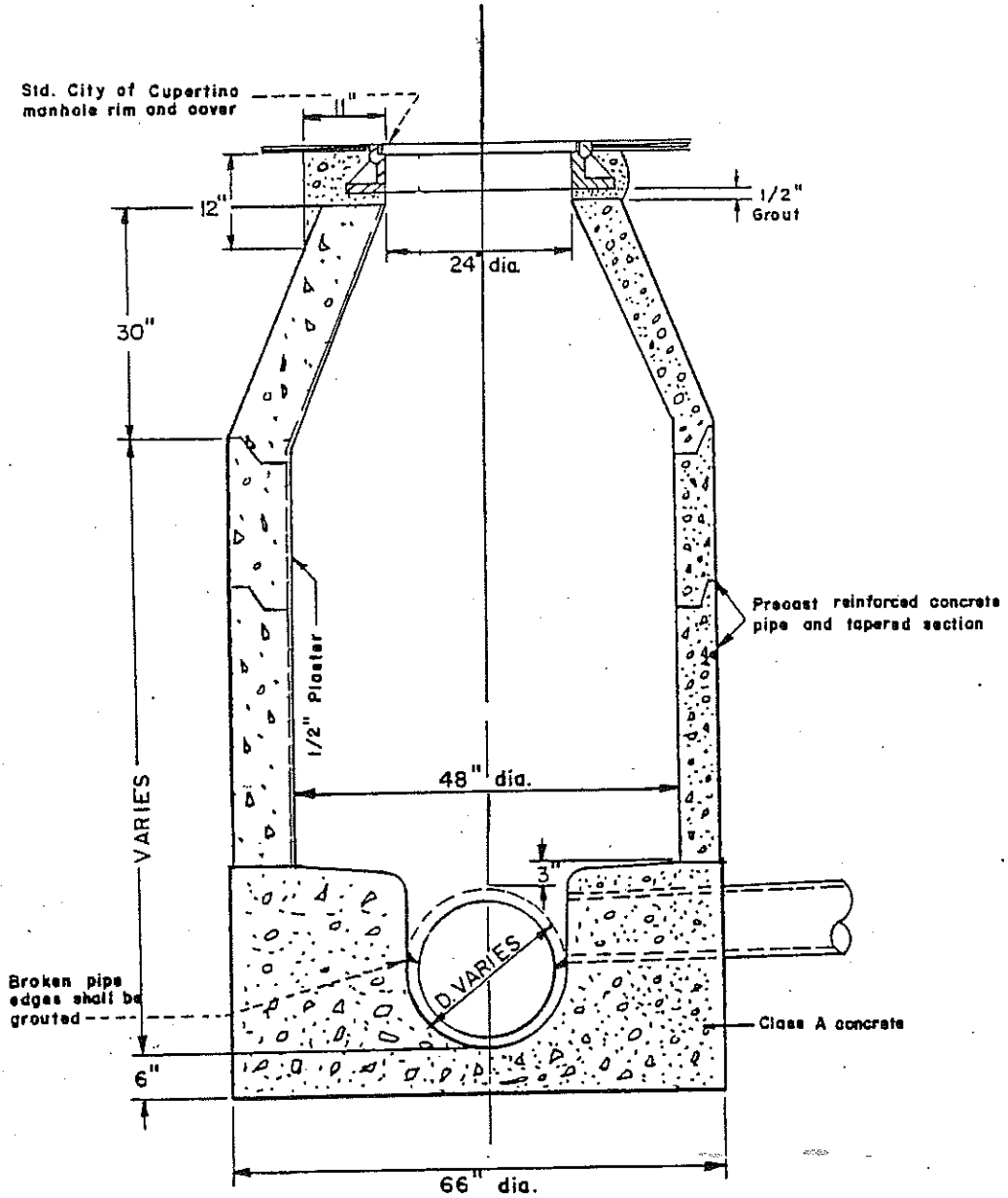

NOTES:

Mortar and grout to conform to Section 65, State Std. Specifications.

Manhole foundation poured in place.

CITY OF CUPERTINO
STANDARD DETAILS

APPROVED BY :

CITY ENGINEER

DATE :

2/10/89

3-10

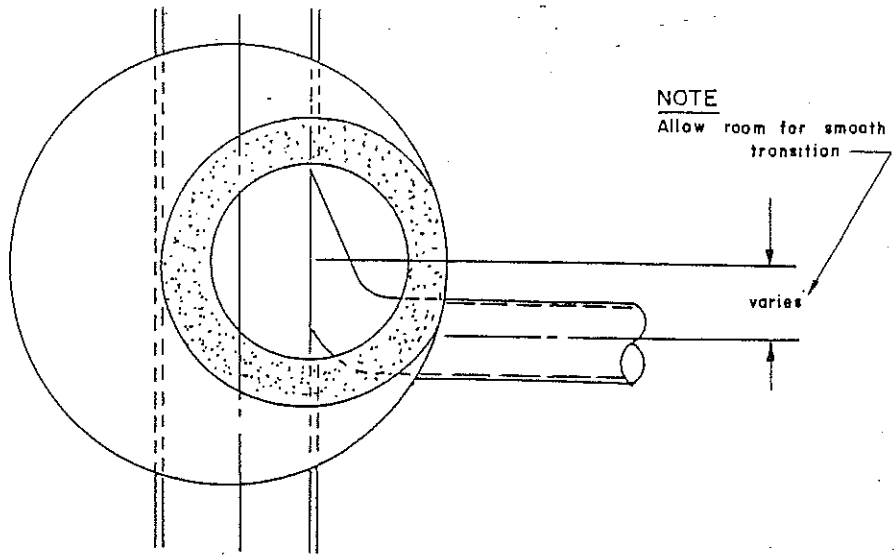

SECTION A-A

Std. City of Cupertino manhole rim and cover

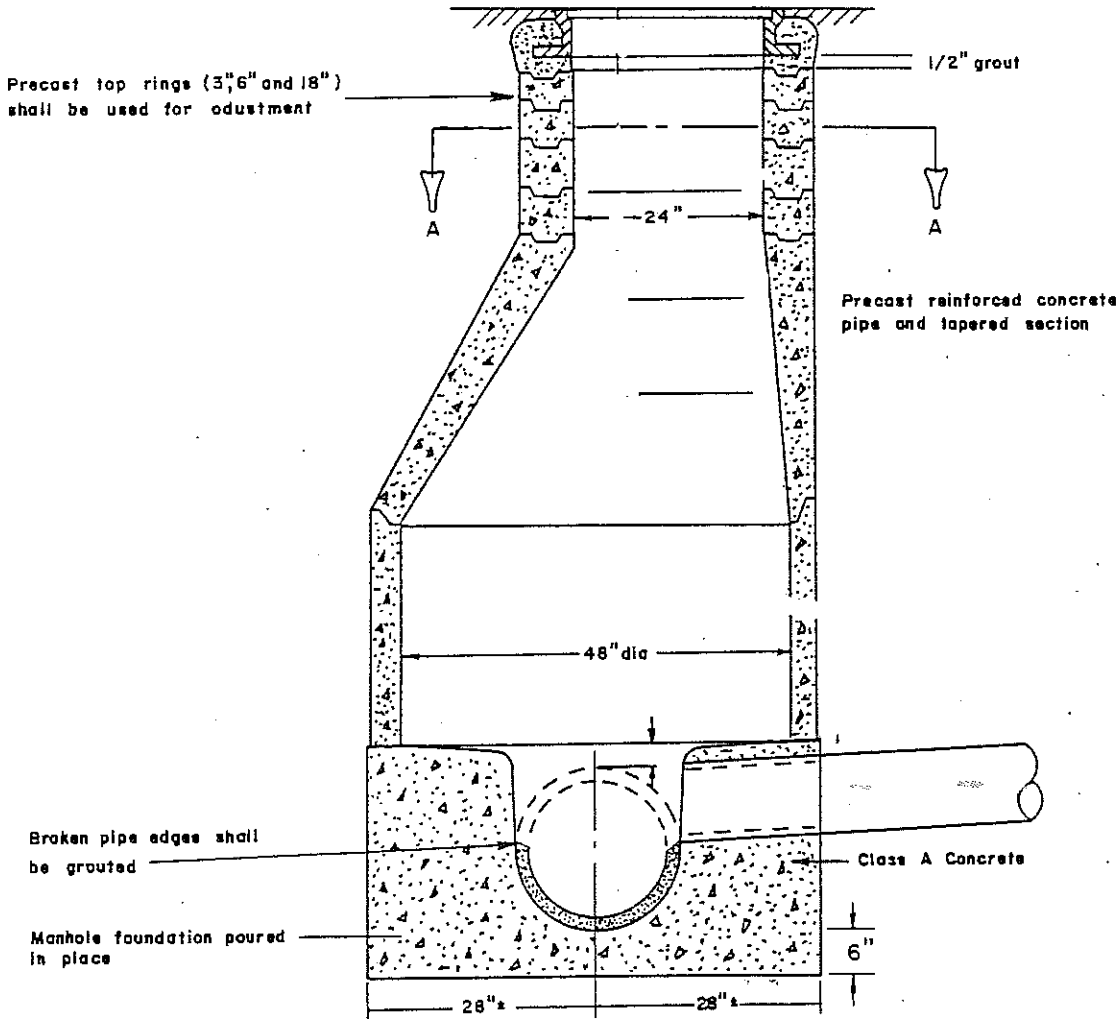

ECCENTRIC MANHOLE

8" to 33" PIPE

**CITY OF CUPERTINO
STANDARD DETAILS**

APPROVED BY :

[Signature]
CITY ENGINEER

DATE :

2/10/89

3-12

ECCENTRIC MANHOLE

36" - 48" DIA. PIPE

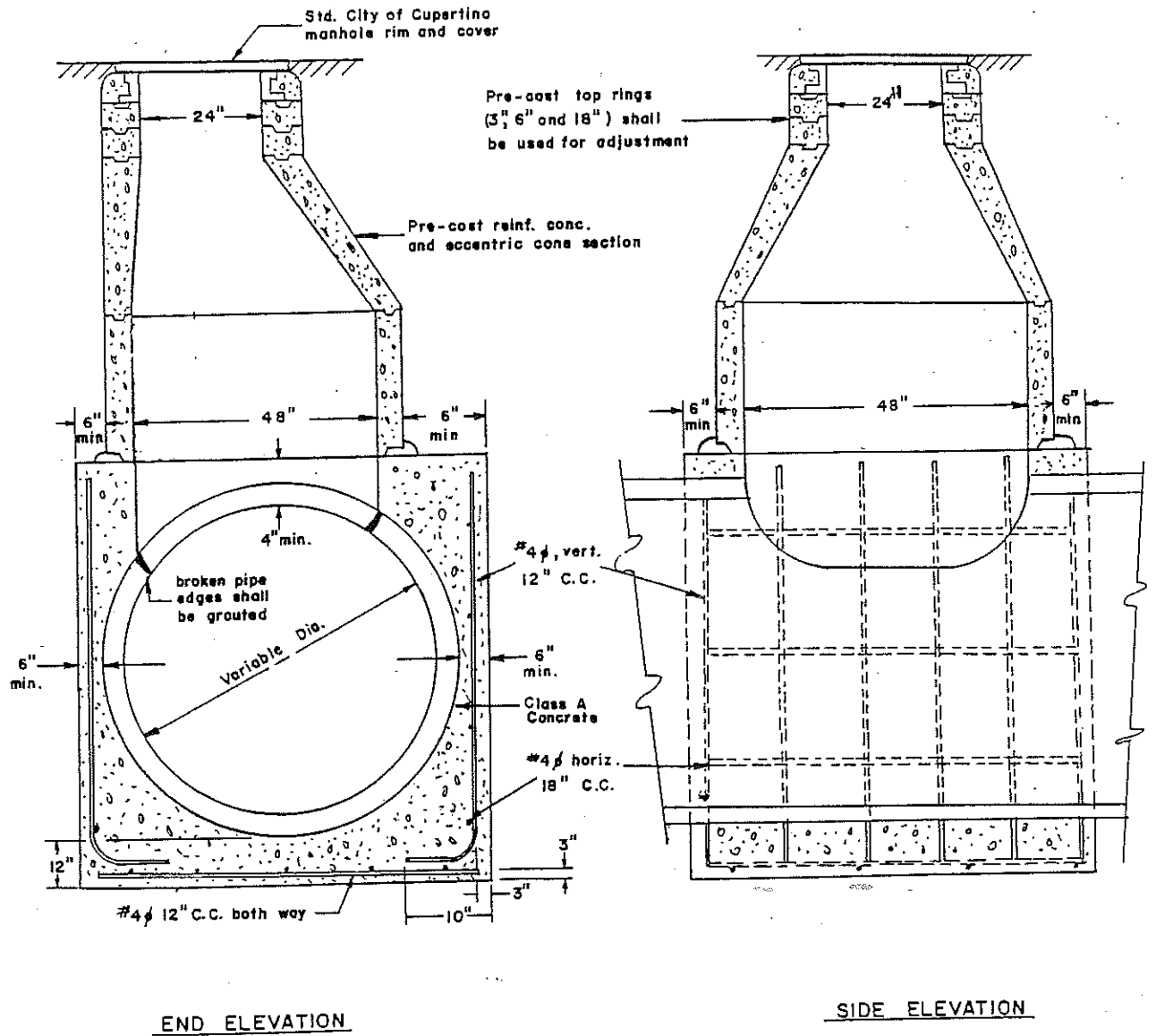

**CITY OF CUPERTINO
STANDARD DETAILS**

APPROVED BY :

[Signature]
CITY ENGINEER

DATE :

2/10/89

3-14

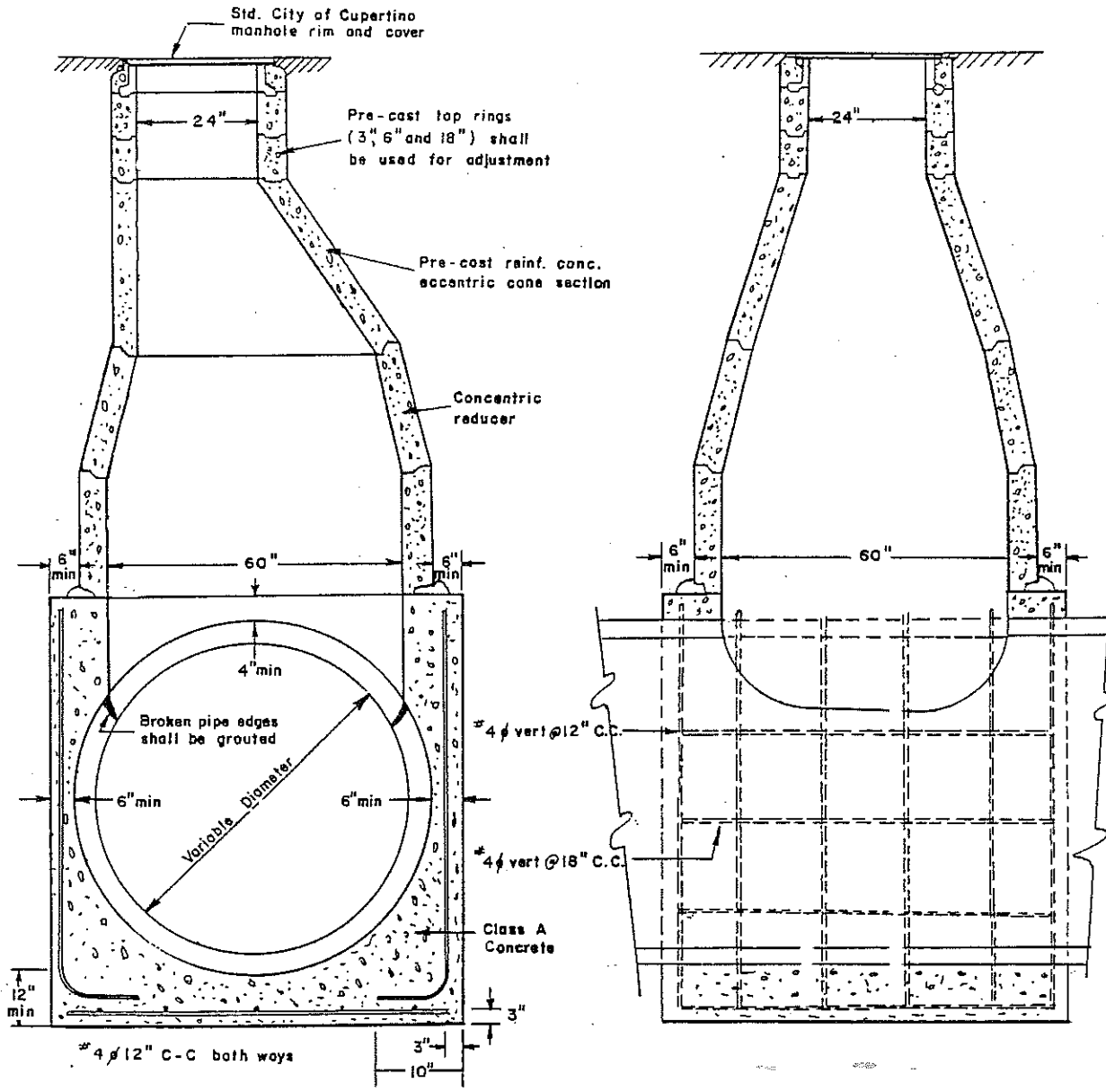

END VIEW

SIDE VIEW

ECCENTRIC MANHOLE

51" PIPE OR LARGER

[Signature]
CITY ENGINEER

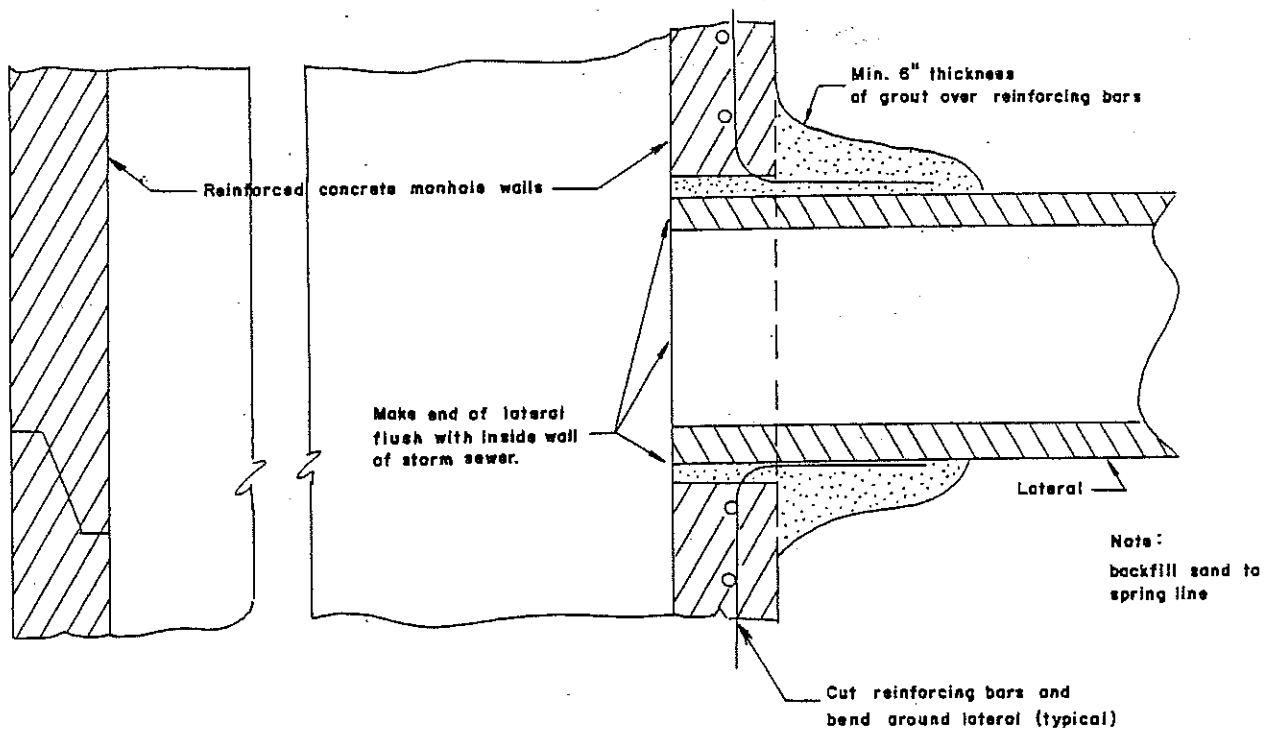

STANDARD CONNECTION TO MANHOLE WALL

CITY OF CUPERTINO
STANDARD DETAILS

APPROVED BY :

[Signature]
CITY ENGINEER

DATE :

2/10/89

3-18

Note:
backfill sand to
spring line.

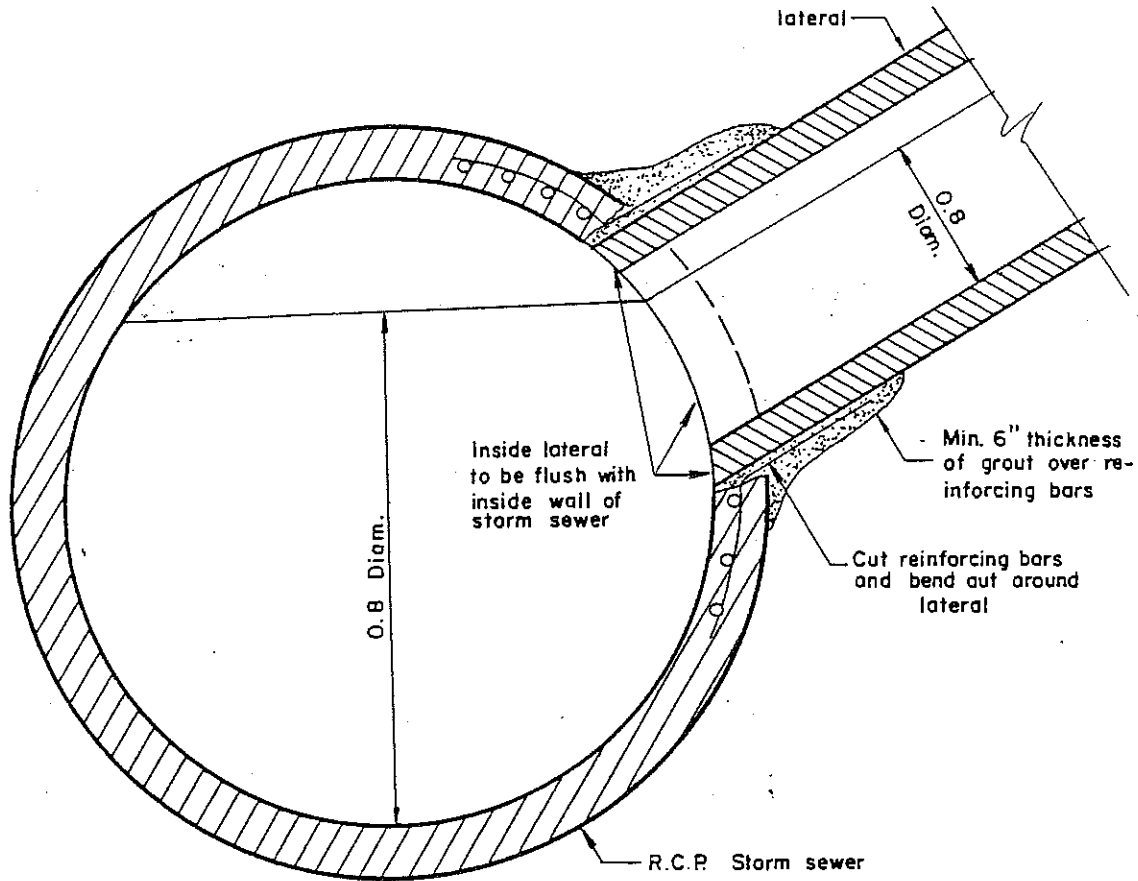

NOTE: Subject to approval of City Engineer.
Smaller pipe diameter shall not exceed
1/4 of the diameter of the larger pipe.

STANDARD CONNECTION TO REINFORCED CONCRETE
PIPE - 48" R.C.P. and LARGER

CITY OF CUPERTINO
STANDARD DETAILS

APPROVED BY

[Signature]
CITY ENGINEER

DATE:

2/10/84

3-20

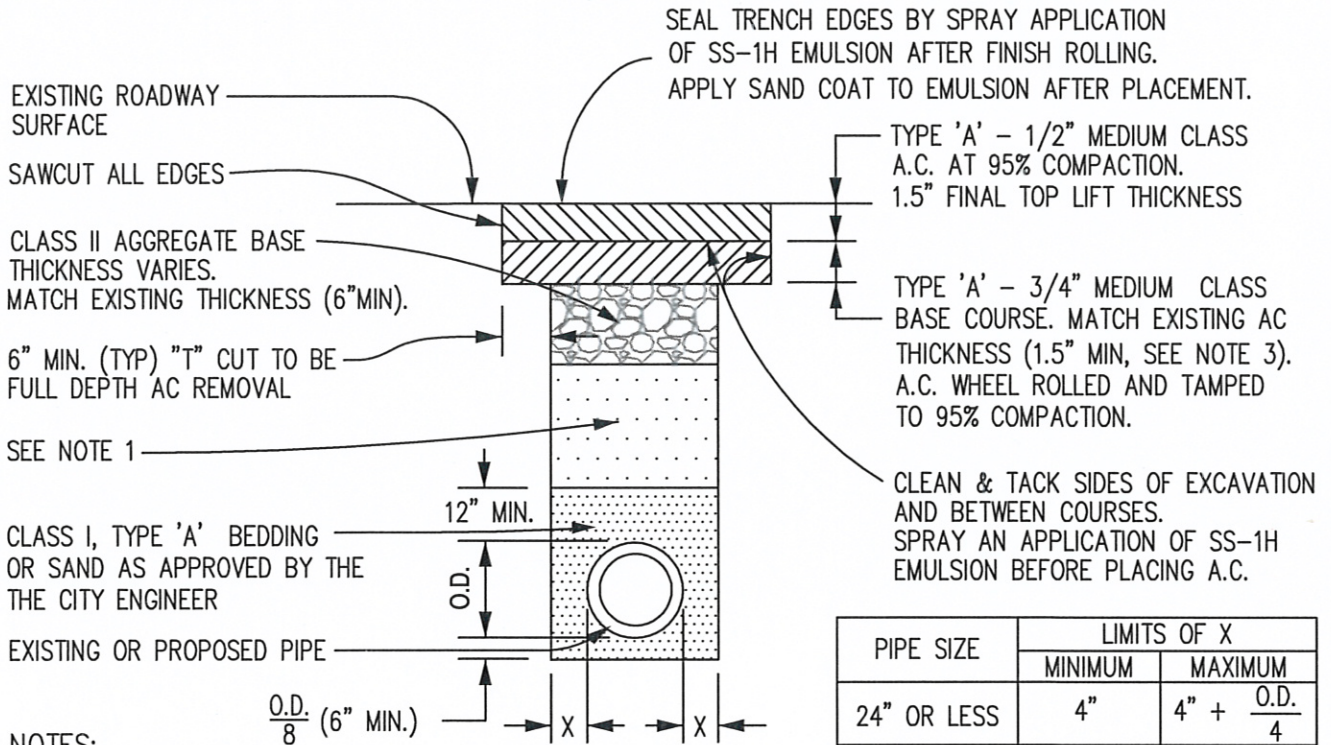

PIPE SIZE	LIMITS OF X	
	MINIMUM	MAXIMUM
24" OR LESS	4"	4" + $\frac{O.D.}{4}$
27" AND GREATER	6"	6" + $\frac{O.D.}{4}$

NOTES:

1) TRENCH BACKFILL:

CLASS II OR CLASS III AGGREGATE BASE AT 95% COMPACTION, OR CONTROLLED DENSITY BACKFILL, SHALL BE USED FOR TRENCH BACKFILL.

NATIVE MATERIALS MAY BE USED AS BACKFILL ONLY WITH WRITTEN CONSENT FROM THE CITY ENGINEER. NATIVE BACKFILL COMPACTION SHALL BE 95%, UNLESS OTHERWISE PERMITTED IN WRITING BY THE CITY ENGINEER. RELATIVE COMPACTION PER ASTM D1557, D2922, D2216 AND 03017. CONTRACTOR SHALL VERIFY SUITABILITY OF NATIVE BACKFILL PRIOR TO BEGINNING CONSTRUCTION.

2) IF EDGE OF TRENCH IS 3' OR LESS FROM THE LIP OF GUTTER, THE CONTRACTOR SHALL REPAVE TO THE LIP OF GUTTER.

3) NEW ASPHALT THICKNESS SHALL MATCH EXISTING ASPHALT THICKNESS (3" MINIMUM TOTAL THICKNESS IS REQUIRED).

EXISTING STREET TRENCH RESTORATION

TO BE USED FOR ALL PUBLIC STORM DRAIN PIPE

REV 2/6/17

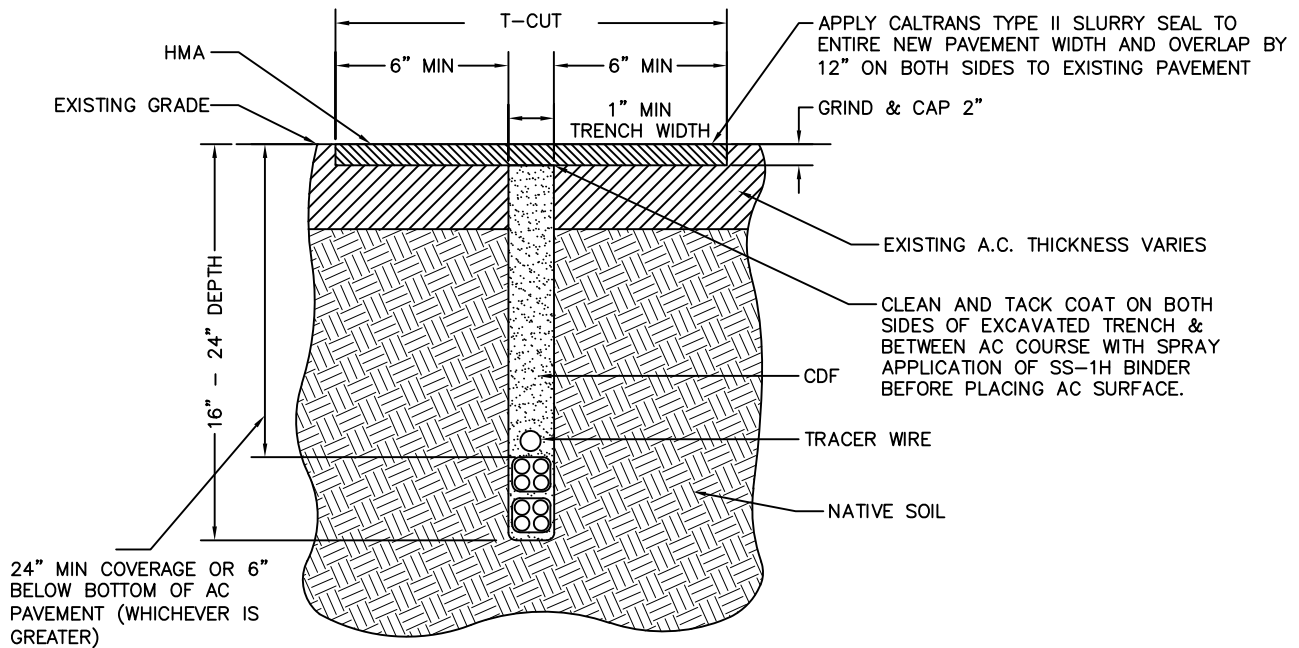

SPECIFICATIONS

LIMITS OF REMOVALS, TRENCH WIDTH AND LOCATION

1. MICROTRENCHING SHALL ONLY BE USED TO INSTALL TELECOMMUNICATION CONDUITS AND WITH APPROVAL AT THE SOLE DISCRETION OF THE CITY ENGINEER.
2. THE MICROTRENCH SHALL BE CONSTRUCTED WITH CONTINUOUS UNIFORM, STRAIGHT AND NEAT EDGES.
3. MICROTRENCH ALIGNMENTS SHALL CONSIST OF RUNS PARALLEL TO THE CENTERLINE OF THE STREET UNLESS APPROVED BY THE CITY ENGINEER. STREET CROSSINGS MAY BE DONE PROVIDED THE ALIGNMENT IS PERPENDICULAR TO THE STREET CENTERLINE TO THE EXTENT POSSIBLE.
4. PREFERRED LOCATION FOR MICROTRENCHES SHALL BE AT THE EXISTING LIP OF GUTTER. FOR ANY MICROTRENCH WITHIN 3- FEET OF THE LIP OF GUTTER, THE PERMITTEE, IN ADDITION TO THE TRENCH T-CUT, SHALL GRIND 2-INCHES DEEP OF PAVEMENT FROM THE EDGE OF THE MICROTRENCH TO THE LIP OF GUTTER AND SHALL RESTORE THE AREA WITH 2" OF HMA.
5. THE MICROTRENCH WIDTH SHALL BE A MINIMUM OF 1".
6. MICROTRENCHING IS NOT ALLOWED THROUGH EXISTING CURB, GUTTER, BUS PAD, PCC STREET SECTIONS, SIDEWALK, PARKSTRIP, SPECIAL PAVEMENTS, SUCH AS DECORATIVE ASPHALT OR PAVERS, OR SIMILAR ELEMENTS.
7. MICROTRENCHING THROUGH A PAVEMENT MORATORIUM STREET IS NOT ALLOWED.
8. THE CONDUIT SHALL BE INSTALLED AT A MINIMUM DEPTH OF 24" BELOW THE EXISTING AC PAVEMENT SURFACE, OR AT LEAST 6" BELOW THE BOTTOM OF THE AC PAVEMENT, WHICHEVER IS GREATER.

BACKFILL

1. ALL MICROTRENCHES SHALL BE COMPLETELY BACKFILLED TO FINISH GRADE BY THE END OF THE WORK DAY WITH CONTROL DENSITY FILL (CDF) THAT MEETS THE BELOW REQUIREMENTS:
 - A. 24 HOUR MINIMUM STRENGTH: 100 PSI
 - B. FULLY CURED (28 DAY) MAXIMUM STRENGTH: 1000 PSI
2. PRIOR TO APPLICATION IN FIELD, SUBMIT CDF MIX DESIGN WITH STRENGTH DATA FOR REVIEW AND APPROVAL. MIX DESIGN MAY ALSO BE SUBJECT TO TESTING.
3. UPON FULL PAVEMENT RESTORATION, APPLY CALTRANS TYPE II SLURRY SEAL TO ENTIRE NEW PAVEMENT WIDTH AND AN ADDITIONAL 12" OF EXISTING PAVEMENT ON BOTH SIDES OF T-CUT.

GRIND AND RESURFACE SECTION

1. COMMENCEMENT OF SURFACE RESTORATION SHALL OCCUR NO SOONER THAN 48 HOURS (BUT NO LATER THAN 30 DAYS) AFTER CDF BACKFILL, AND AS NECESSARY TO ENSURE PROPER CURING OF MATERIAL. AS SOON AS CDF BACKFILL HAS CURED, EXISTING AC PAVEMENT AND CDF BACKFILL SHALL BE GROUND DOWN 2", FOR NO LESS THAN 6" FROM BOTH EDGES OF THE MICROTRENCH AND RESURFACE WITH HMA.
2. THE 2" SURFACE CAP SHALL BE PLACED THE SAME DAY AS THE PAVEMENT GRINDING. ALL LOCATIONS OPENED WITH A GRINDER MUST BE PAVED BY THE END OF THE DAY. NO PORTION OF ROADWAY SHALL REMAIN BELOW SURFACE GRADE AFTER WORKING HOURS UNLESS APPROVED BY THE CITY ENGINEER.

VAULTS AND SERVICE CONNECTORS

1. CONNECTION TO SERVICE LATERALS, JUNCTION BOXES, ETC., SHALL BE DONE SUCH THAT THE CURB AND GUTTER IS NOT DISTURBED, SETTLED, OR DAMAGED. REMOVAL LIMITS OF SIDEWALK SHALL FOLLOW APPLICABLE STANDARD AND REQUIREMENTS AS APPROVED BY THE CITY ENGINEER.

MICROTRENCHING - DETAIL AND SPECIFICATIONS

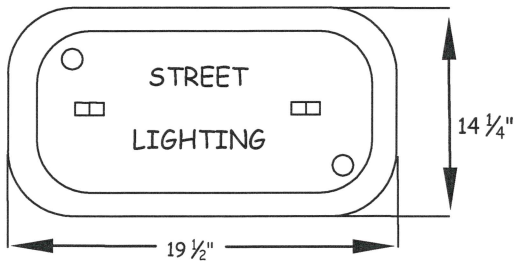
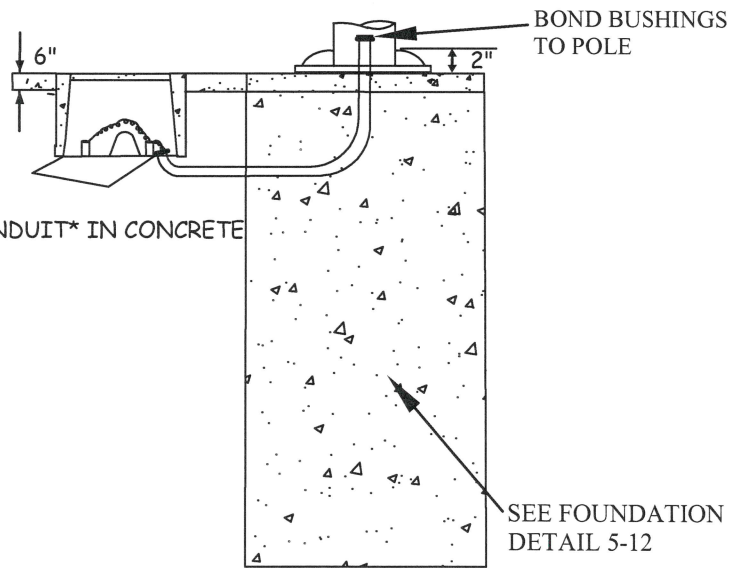
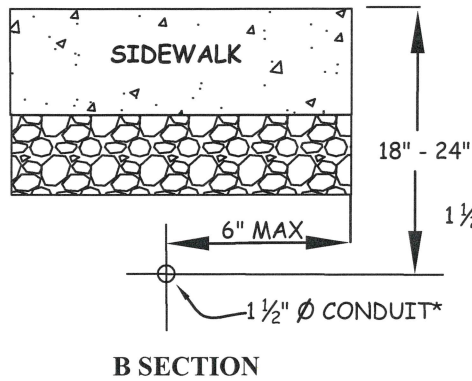
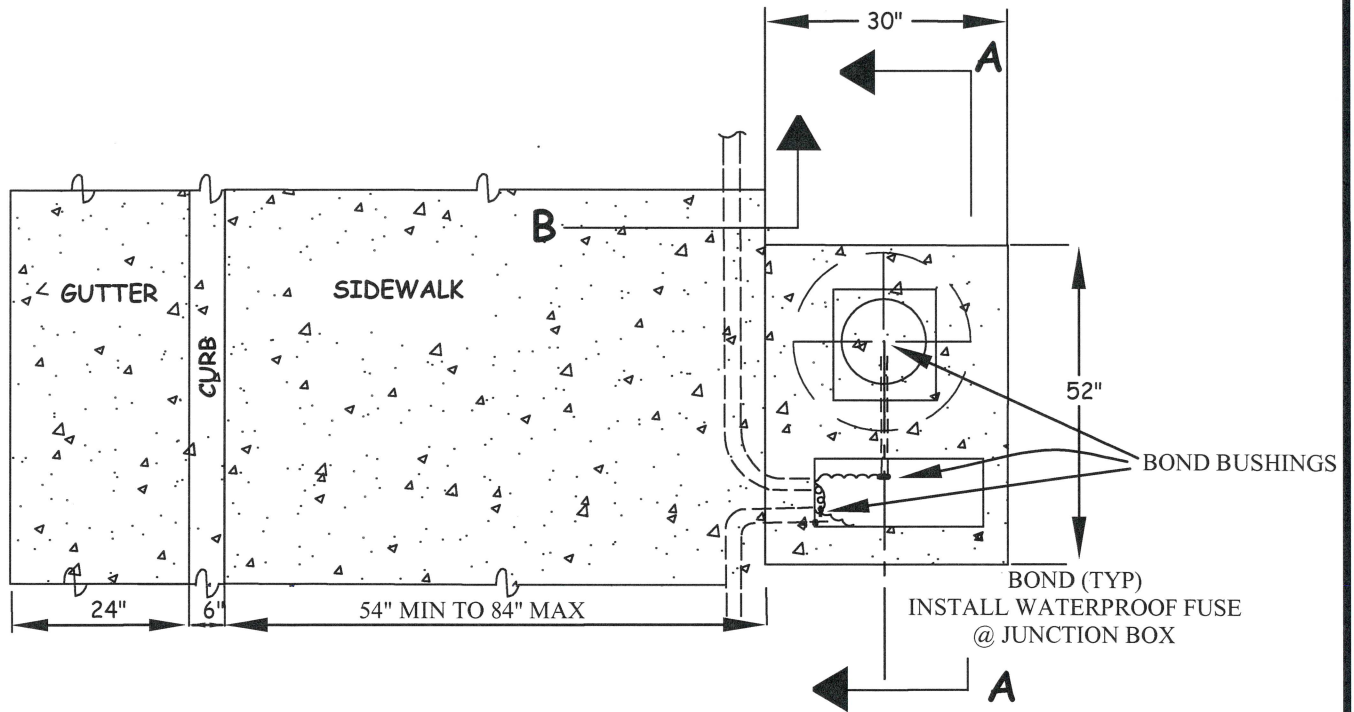

JUNCTION BOX
 STATE OF CALIFORNIA #3 1/2 - CONCRETE BOX
 NOTE: BOTTOM OF BOX SHALL BE LINED WITH CONCRETE. A 3/4" DRAIN HOLE SHALL BE PLACED AT LOW POINT IN CONCRETE

***CONDUIT SHALL BE RIGID METAL UNLESS PVC IS APPROVED BY THE PUBLIC WORKS DEPARTMENT (PVC IS PROHIBITED WITHIN POLE FOUNDATION)**

ELECTROLIER AND CONDUIT LOCATION

SEE LIGHTING NOTES FOR OTHER ADDITIONAL INFORMATION

CITY OF CUPERTINO
 STANDARD DETAILS

APPROVED BY:

[Signature]
 City Engineer

DATE:

6/5/19

5-2

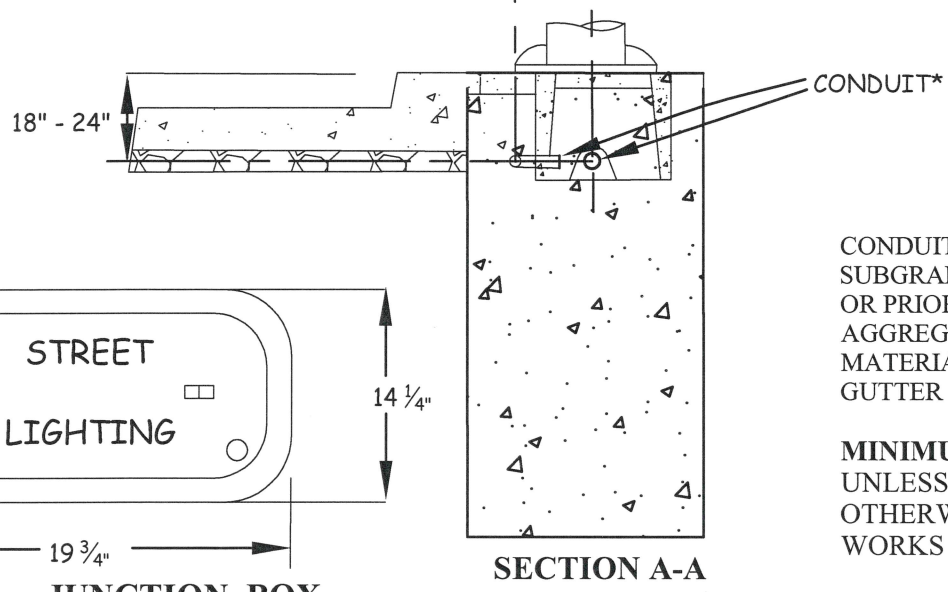
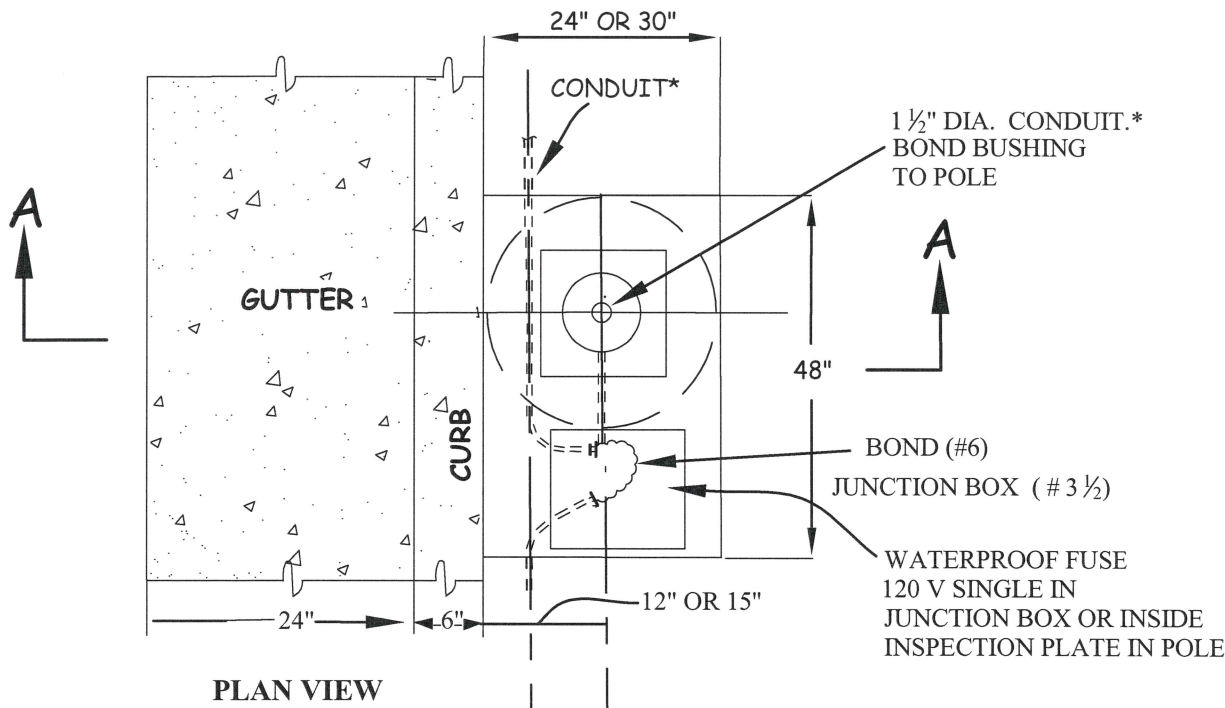

CONDUIT* TO BE PLACED ON
SUBGRADE BY TRENCHING
OR PRIOR TO PLACEMENT OF
AGGREGATE BASE
MATERIAL FOR CURB AND
GUTTER

MINIMUM DEPTH 24"
UNLESS APPROVED
OTHERWISE BY PUBLIC
WORKS DEPARTMENT

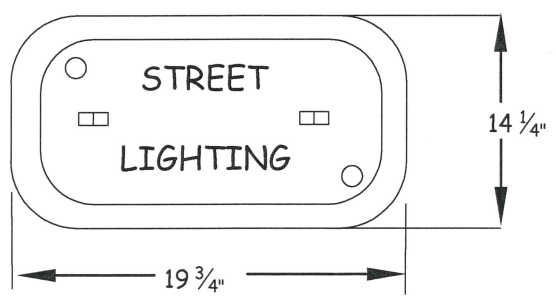

STATE OF CALIFORNIA #3 1/2 - CONCRETE BOX
NOTE: BOTTOM OF BOX SHALL BE LINED WITH
CONCRETE. A 3/4" DRAIN HOLE SHALL BE PLACED
AT LOW POINT IN CONCRETE

***CONDUIT SHALL BE RIGID METAL UNLESS PVC IS
APPROVED BY THE PUBLIC WORKS DEPARTMENT
(PVC IS PROHIBITED WITHIN POLE FOUNDATION)**

ELECTROLIER AND CONDUIT LOCATION

SEE LIGHTING NOTES FOR OTHER ADDITIONAL INFORMATION

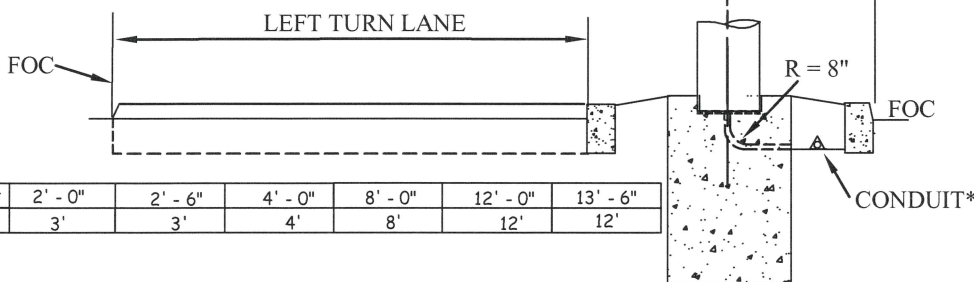
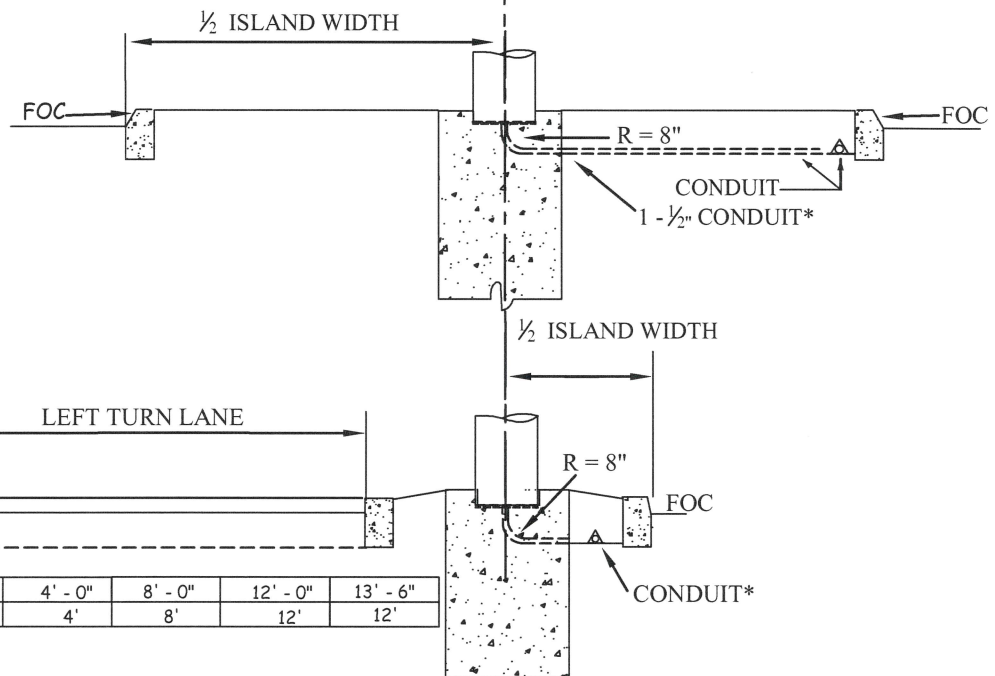
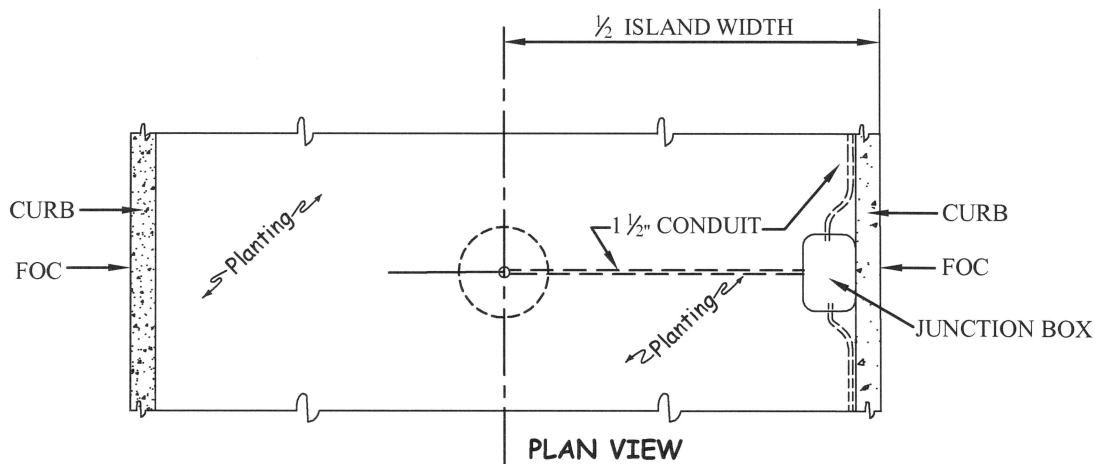

FOC to \mathcal{C} elect	2' - 0"	2' - 6"	4' - 0"	8' - 0"	12' - 0"	13' - 6"
Arm Length	3'	3'	4'	8'	12'	12'

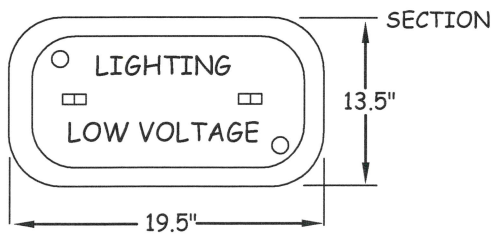

JUNCTION BOX

STATE OF CALIFORNIA #3 1/2 - CONCRETE BOX
 NOTE: BOTTOM OF BOX SHALL BE LINED WITH CONCRETE AND A 3/4" DRAIN HOLE SHALL BE PLACED AT LOW POINT IN CONCRETE

MINIMUM DEPTH 24"
 UNLESS APPROVED OTHERWISE BY PUBLIC WORKS DEPARTMENT

CONDUIT* TO BE PLACED ON SUBGRADE BY TRENCHING OR PRIOR TO PLACEMENT OF AGGREGATE BASE MATERIAL FOR CURB AND GUTTER

*CONDUIT SHALL BE RIGID METAL UNLESS PVC IS APPROVED BY THE PUBLIC WORKS DEPARTMENT

ELECTROLIER AND CONDUIT LOCATION IN MEDIAN ISLANDS

***CONDUIT SHALL BE RIGID METAL UNLESS PVC IS APPROVED BY THE PUBLIC WORKS DEPARTMENT**

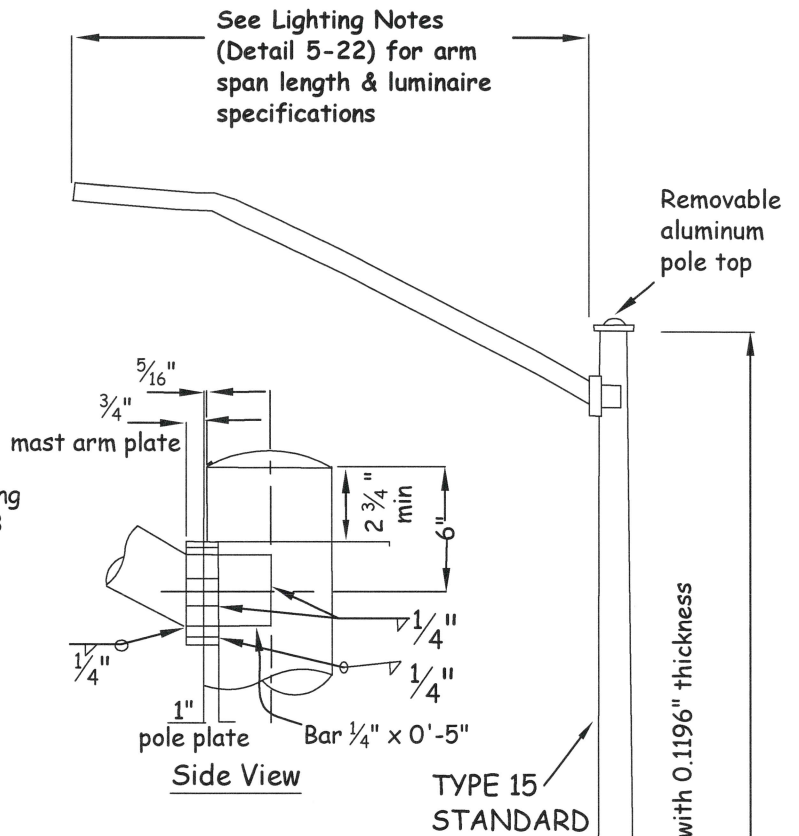
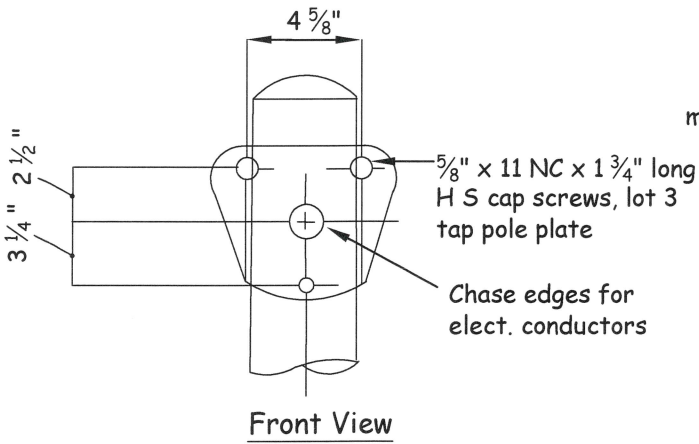

ARM ATTACHMENT DETAIL

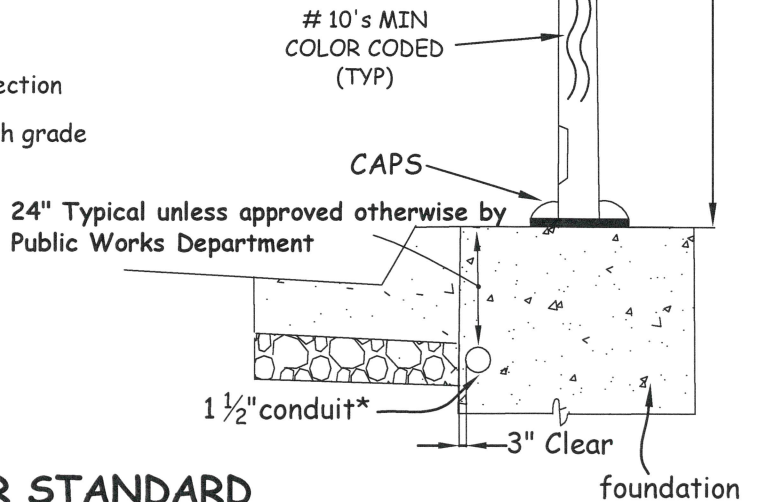
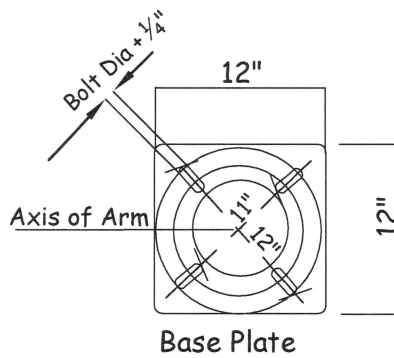
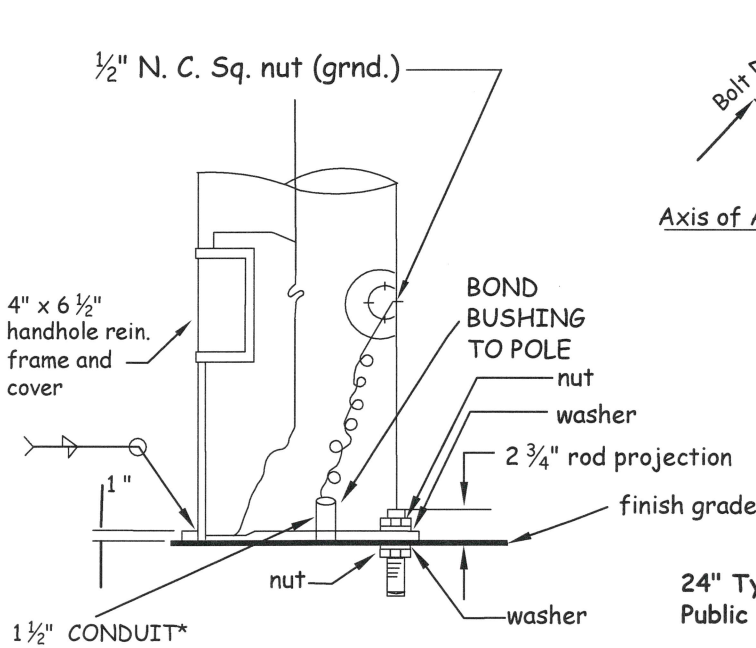

35' ELECTROLIER STANDARD

SEE LIGHTING NOTES FOR ADDITIONAL INFORMATION

***CONDUIT SHALL BE RIGID METAL UNLESS PVC IS APPROVED BY THE PUBLIC WORKS DEPARTMENT (PVC IS PROHIBITED WITHIN POLE FOUNDATION)**

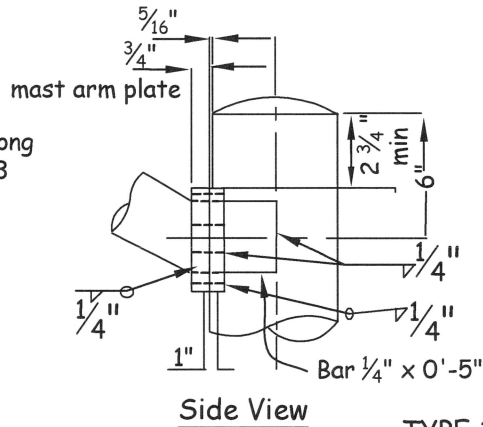
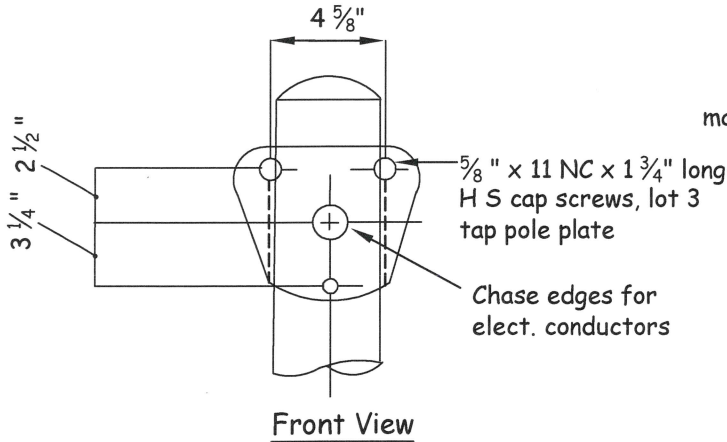
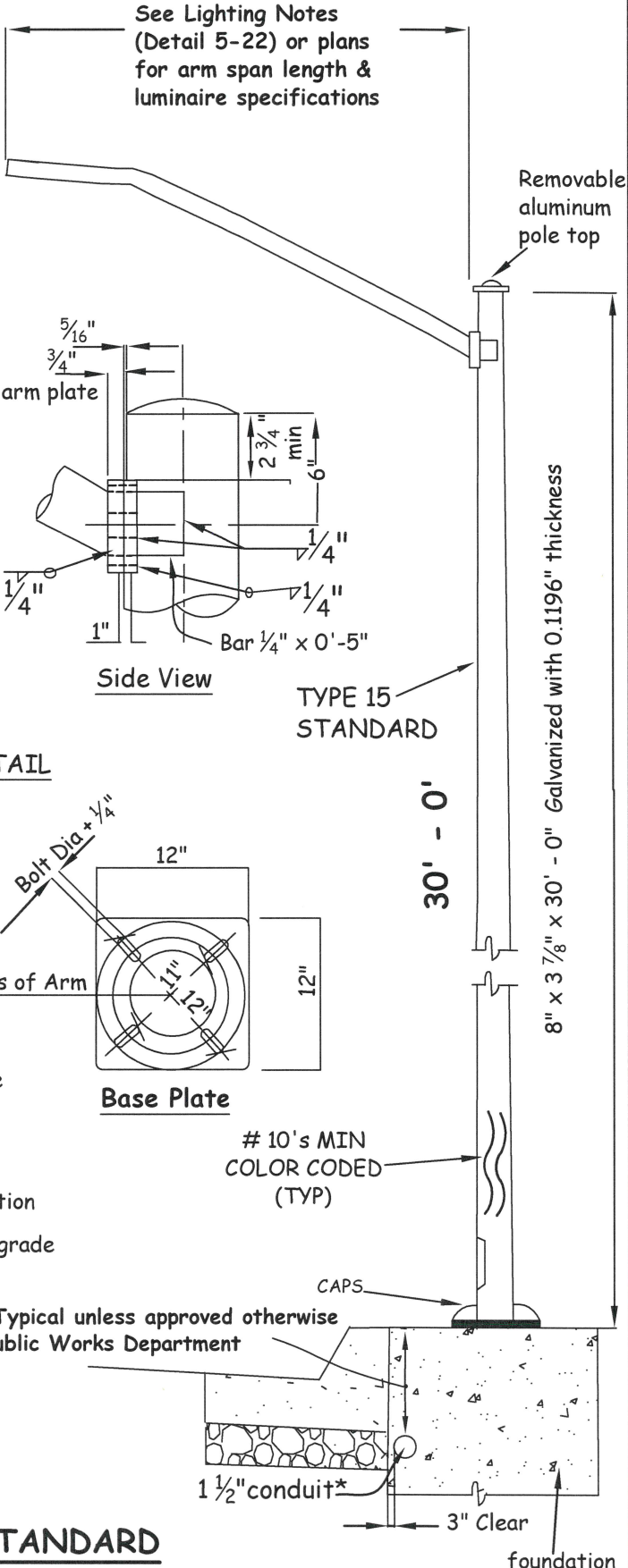

ARM ATTACHMENT DETAIL

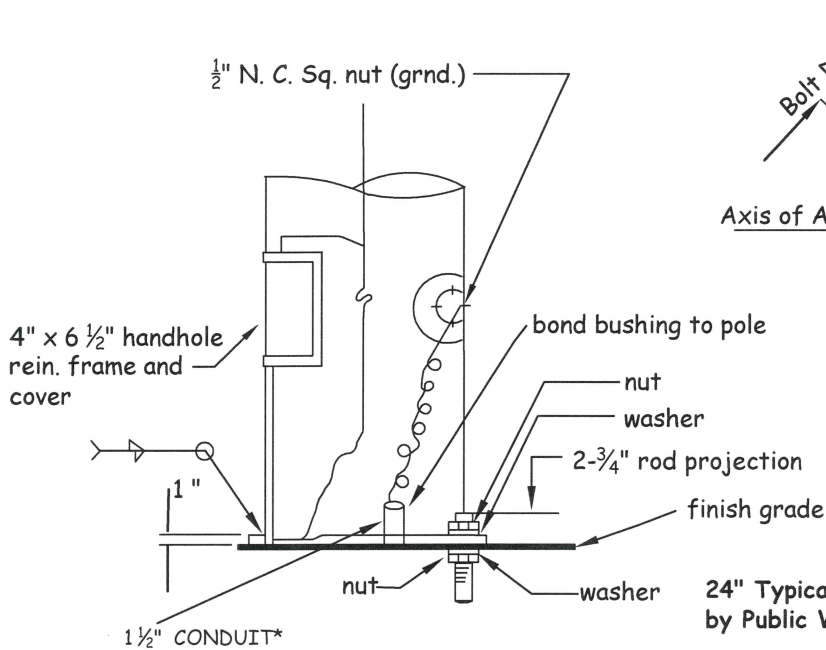

Note: Handhole shall be located on down stream side of traffic.

30' ELECTROLIER STANDARD

SEE LIGHTING NOTES FOR ADDITIONAL INFORMATION
30' POLE IS STANDARD POLE HEIGHT UNLESS OTHERWISE NOTED

SEE OTHER SHEETS
FOR BOX DETAILS

1" or 1 1/2" bolt
circle

FOUNDATION DIAMETER

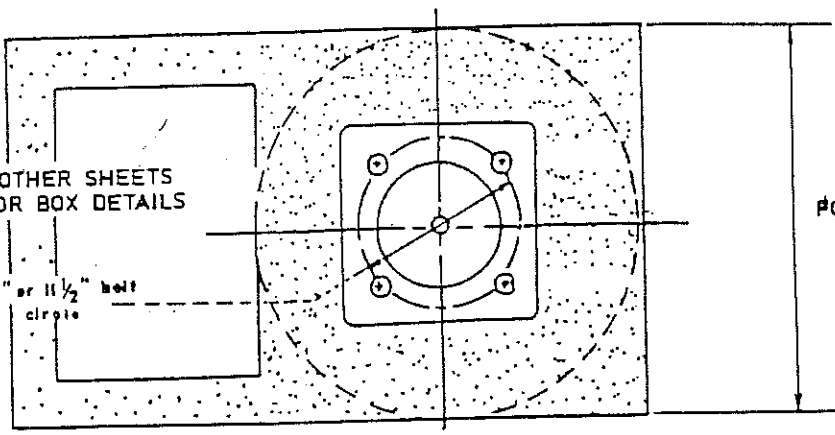

GROUND CLAMP ON CONDUIT

GROUND LUG ON POLE

GROUND CONDUCTOR W/18"
OF SLACK

BOLT AND BASE COVERS
SHALL BE INSTALLED

finish
pour

rod projection

SEE OTHER DETAILS FOR LOCATION

GROUND CLAMP
BOND (TYP)

18" OR 24"

ALL 4 BOLTS
GROUNDED

1 1/2" DIA. RIGID METAL
CONDUIT IN CONCRETE
FOUNDATION

60"
min.

tie wire

For 30'0" standard:
(4) 1" dia. x 36" x 4" galvanized
anchor rods with 2 galvanized hex
nuts and flat washers per rod.

For 35'0" standard:
(4) 1 1/4" dia. x 40" x 4" galv.
anchor rods.

(4) 1/2" reinforcing rods

24"
over
lap

#6 A.W.G. COPPER GROUND
CONDUCTOR

8'-5/8" DIA. COPPER
GROUND ROD WITH
CLAMP

NOTES:

- 1) 2500 PSI CONCRETE
- 2) NO BENDING OF ANCHOR BOLTS WILL BE ALLOWED
- 3) BOND ALL METAL PER NEC

30" sq. or round for 35' stand.
24" sq. or round for 30' stand.

ELECTROLIER FOUNDATION

REVISED 9/16/99

***CONDUIT SHALL BE RIGID METAL UNLESS PVC IS APPROVED BY THE PUBLIC WORKS DEPARTMENT**

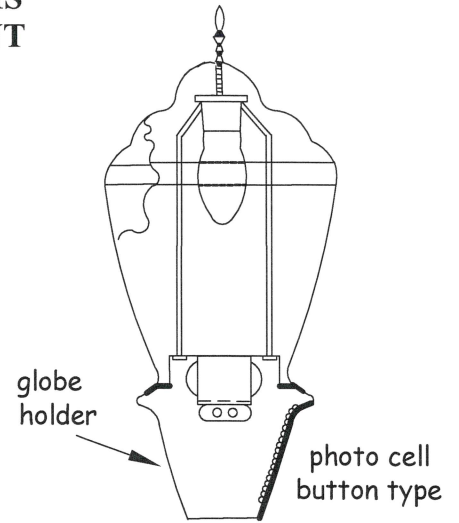
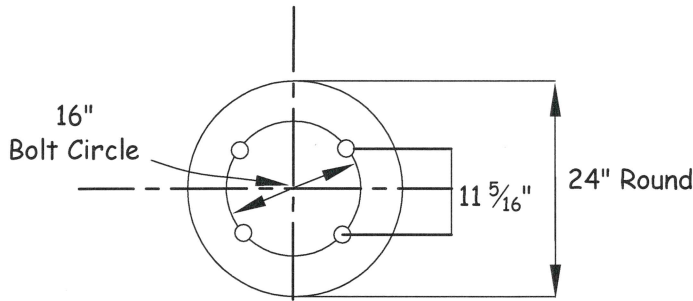

Switch (PEC)

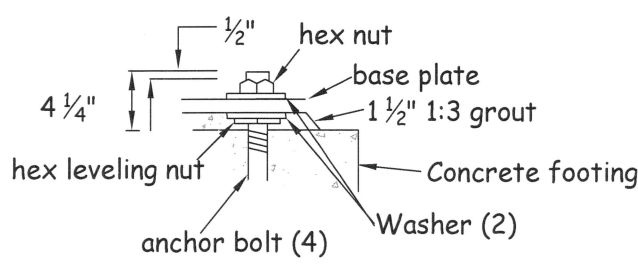
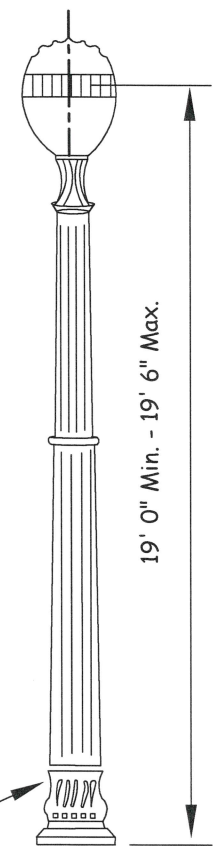
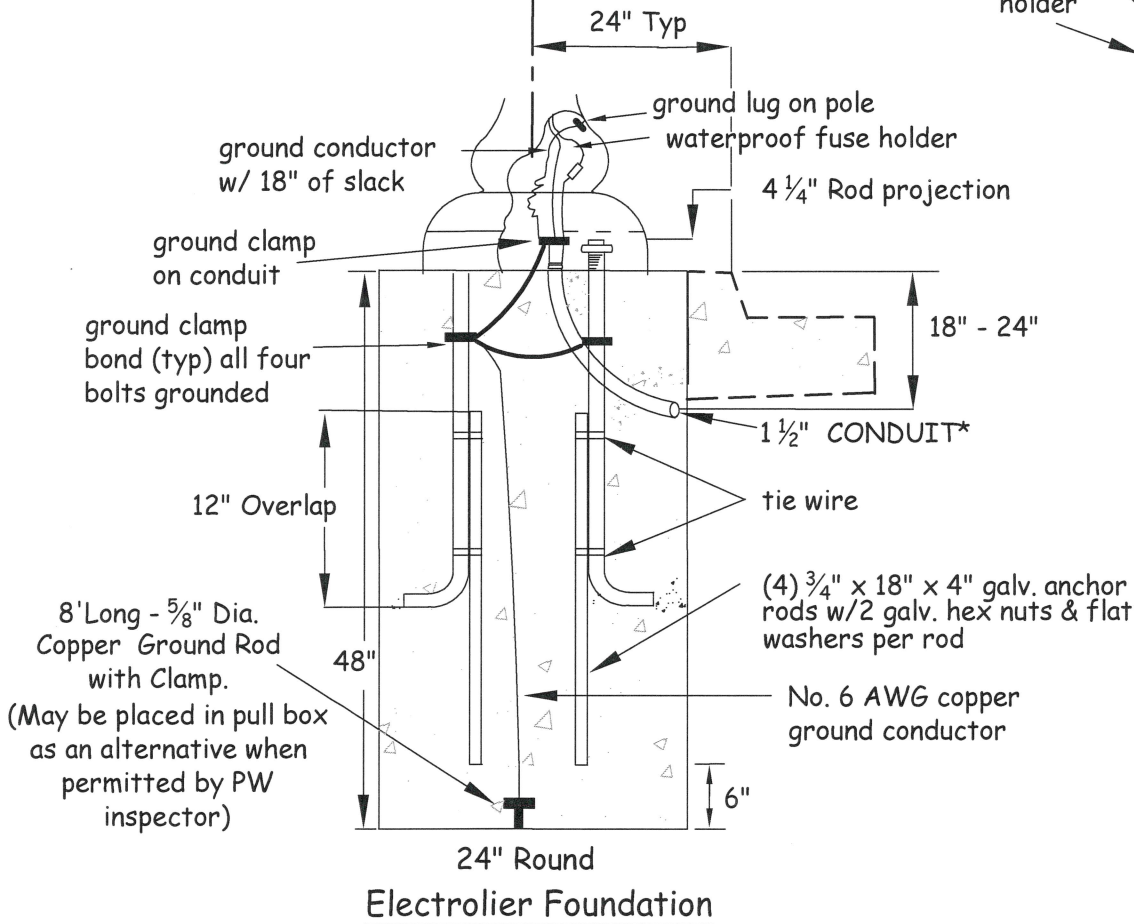

Base Plate & Anchor Bolt

TRADITIONAL ELECTROLIER

CONDUIT DETAIL LOOP DETECTOR LEAD-IN WIRES

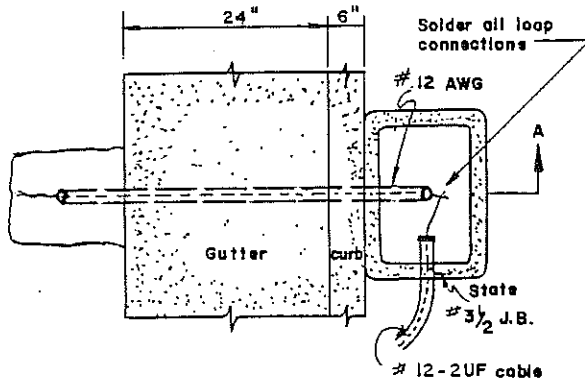

PLAN

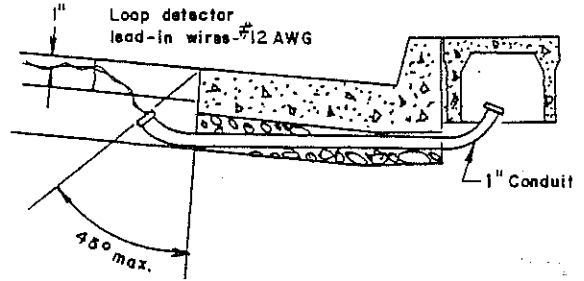

SECTION A

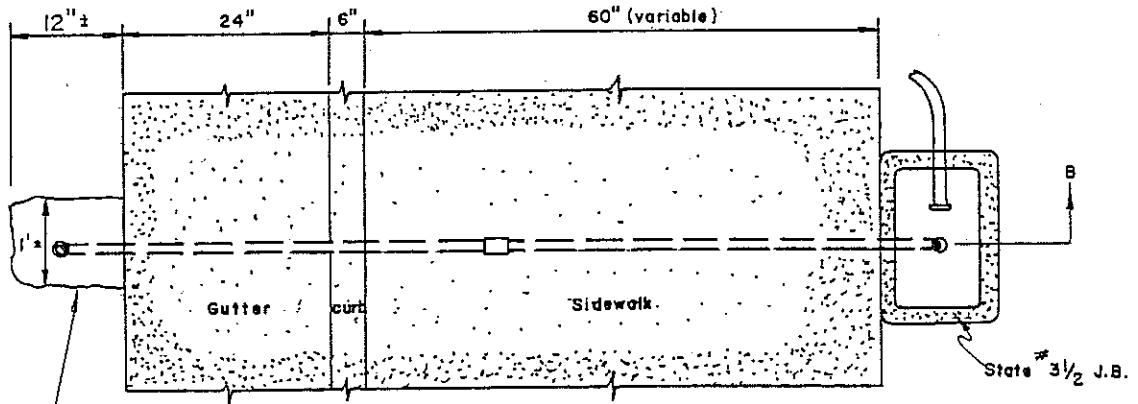

PLAN

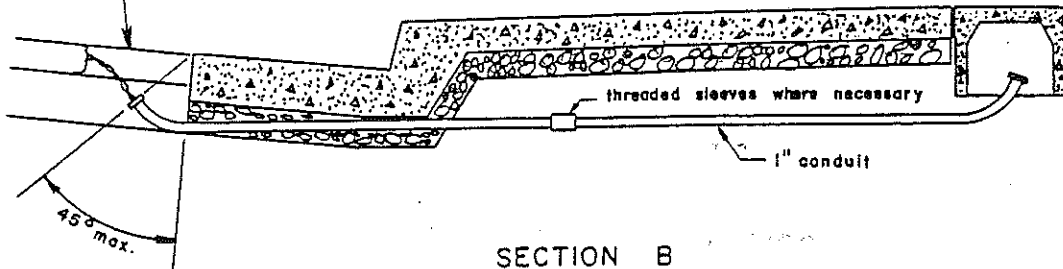

SECTION B

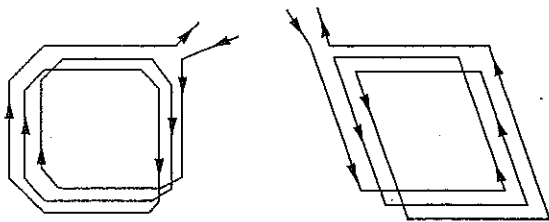

WINDING DETAIL

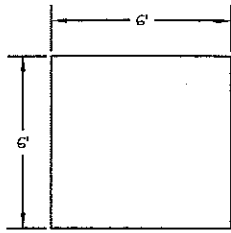

SAWCUT DETAIL

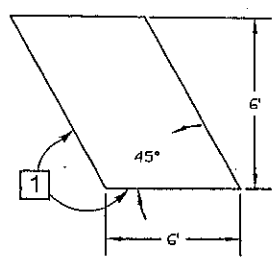

1 ROUND CORNERS OF ACUTE ANGLES TO PREVENT DAMAGE TO CONDUCTORS.

TERMINATION

TYPE 3S

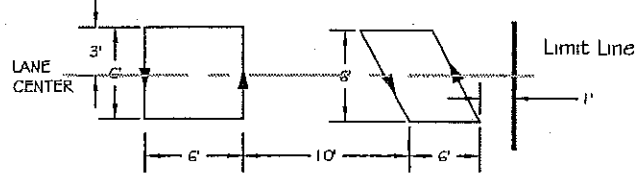
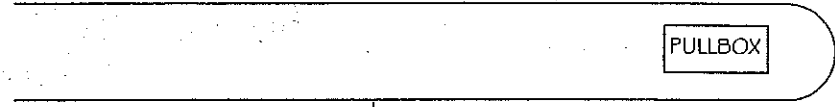

TYPE 4S

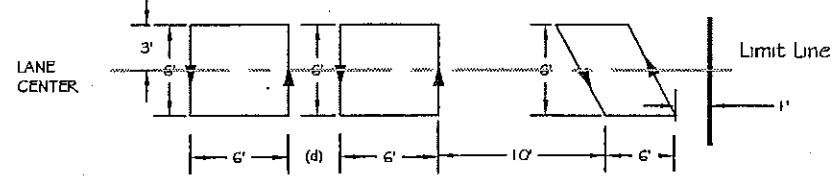

TYPE 5S

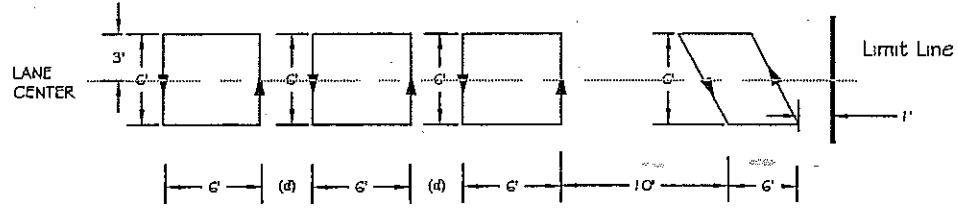

GENERAL NOTES:

d = 10' unless noted otherwise

TYPICALLY USED IN LEFT TURN POCKETS.
HOWEVER, MAY BE USED FOR LIMIT LINE
DETECTION.

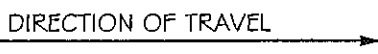

TYPE 'S A' LOOP INSTALLATION

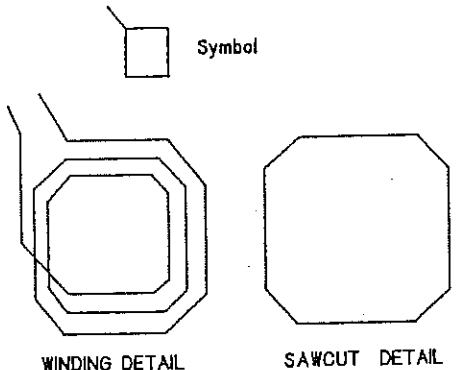

TYPE A LOOP DETECTOR CONFIGURATION

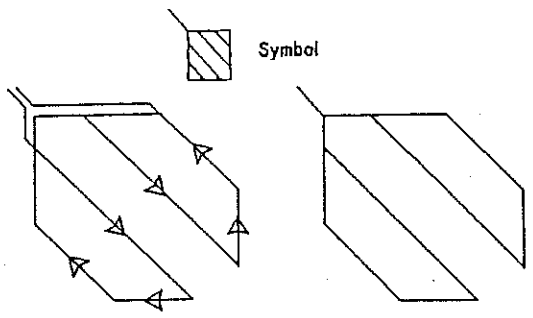

TYPE D LOOP DETECTOR CONFIGURATION

- 1 ROUND CORNER OF ACUTE ANGLES TO PREVENT DAMAGE TO CONDUCTORS
- 2 INSTALL FIVE (5) TURNS WHEN ONE TYPE D LOOP IS IN SERIES WITH AN ADDITIONAL 6' X 6' LOOP ON A SENSOR UNIT CHANNEL FOR SLOT DETAIL. SEE, LOOP INSTALLATION PROCEDURE, STANDARD PLAN, ES - 5A

TYPE 3DA

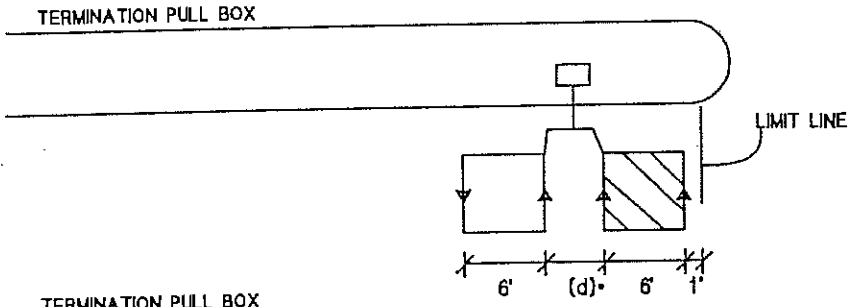

TYPE 4DA(d)

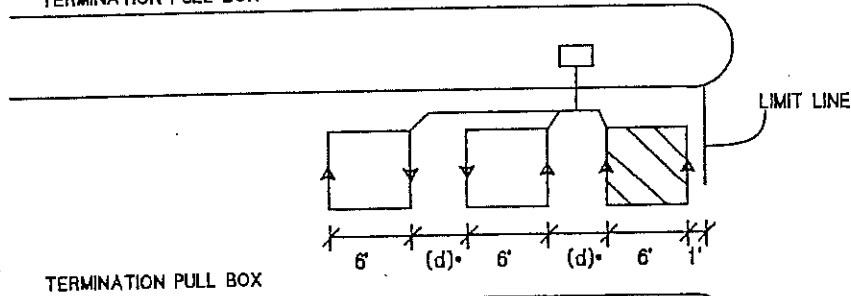

TYPE 5DA(d)

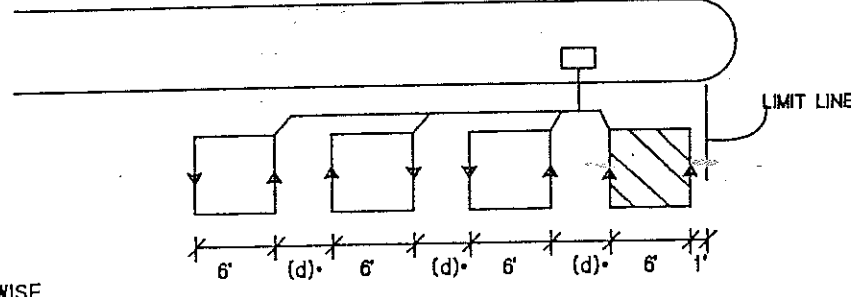

• d= 10", UNLESS NOTED OTHERWISE

→ DIRECTION OF TRAVEL

TYPE 'DA' LOOP INSTALLATION

<p>CITY OF CUPERTINO STANDARD DETAIL</p>	<p>APPROVED: <i>[Signature]</i> DATE: <u>7/27/94</u> CITY ENGINEER</p>	<p>5-18</p>
--	--	-------------

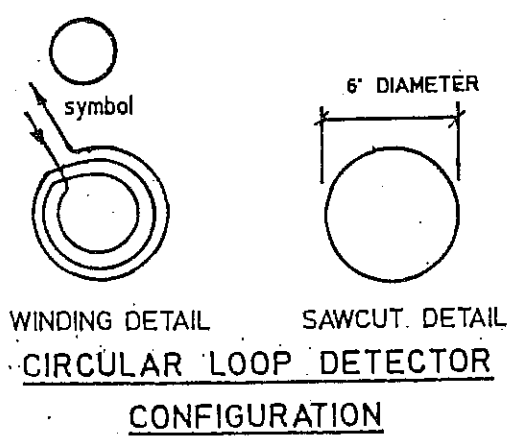

WINDING DETAIL SAWCUT DETAIL
CIRCULAR LOOP DETECTOR
CONFIGURATION

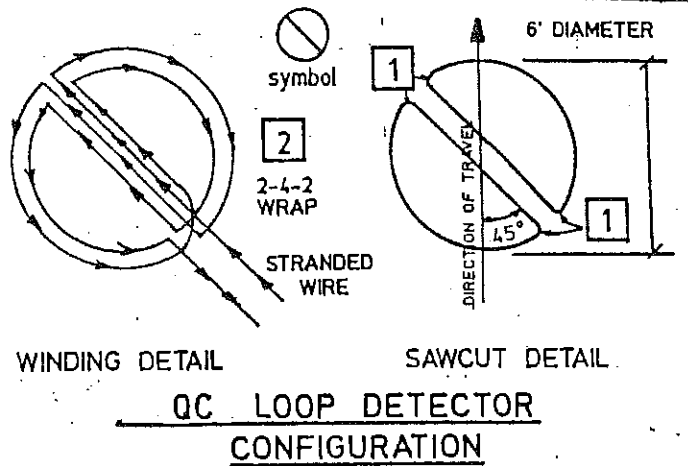

WINDING DETAIL SAWCUT DETAIL
QC LOOP DETECTOR
CONFIGURATION

- 1 ROUND CORNERS OF ACUTE ANGLES TO PREVENT DAMAGE TO CONDUCTORS
- 2 INSTALL 2-4-2 TURNS WHEN ONE TYPE PHASE LOOP IS IN SERIES WITH AN ADDITIONAL CIRCULAR LOOP ON A SENSOR UNIT CHANNEL FOR SLOT DETAIL SEE, LOOP INSTALLATION PROCEDURE, STANDARD PLAN, ES-5A

TYPE 3 QC / CIRCULAR (d) *

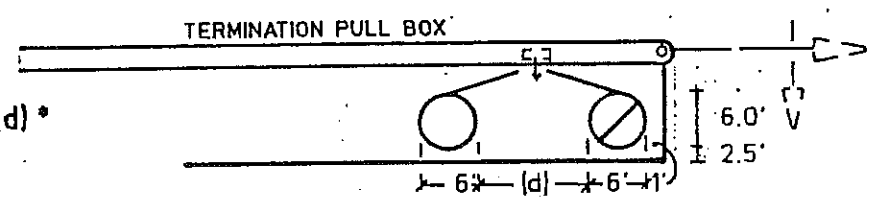

TYPE 4 QC / CIRCULAR (d) *

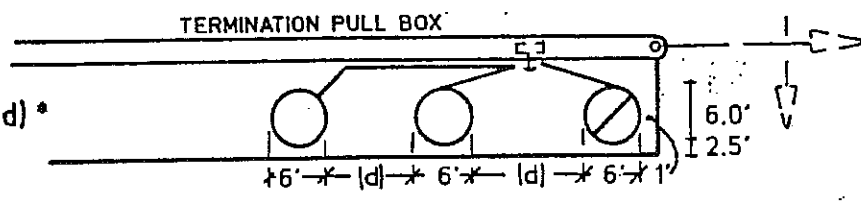

TYPE 5 QC / CIRCULAR (d) *

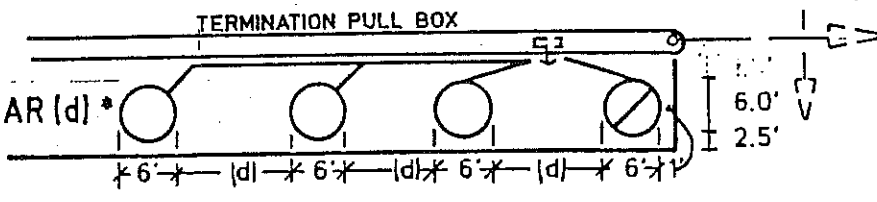

DIRECTION OF TRAVEL →

TYPE QC / CIRCULAR LOOP INSTALLATION

*d = 10' Unless noted otherwise

***CONDUIT SHALL BE RIGID METAL UNLESS PVC IS APPROVED BY THE PUBLIC WORKS DEPARTMENT (PVC IS PROHIBITED WITHIN POLE FOUNDATION)**

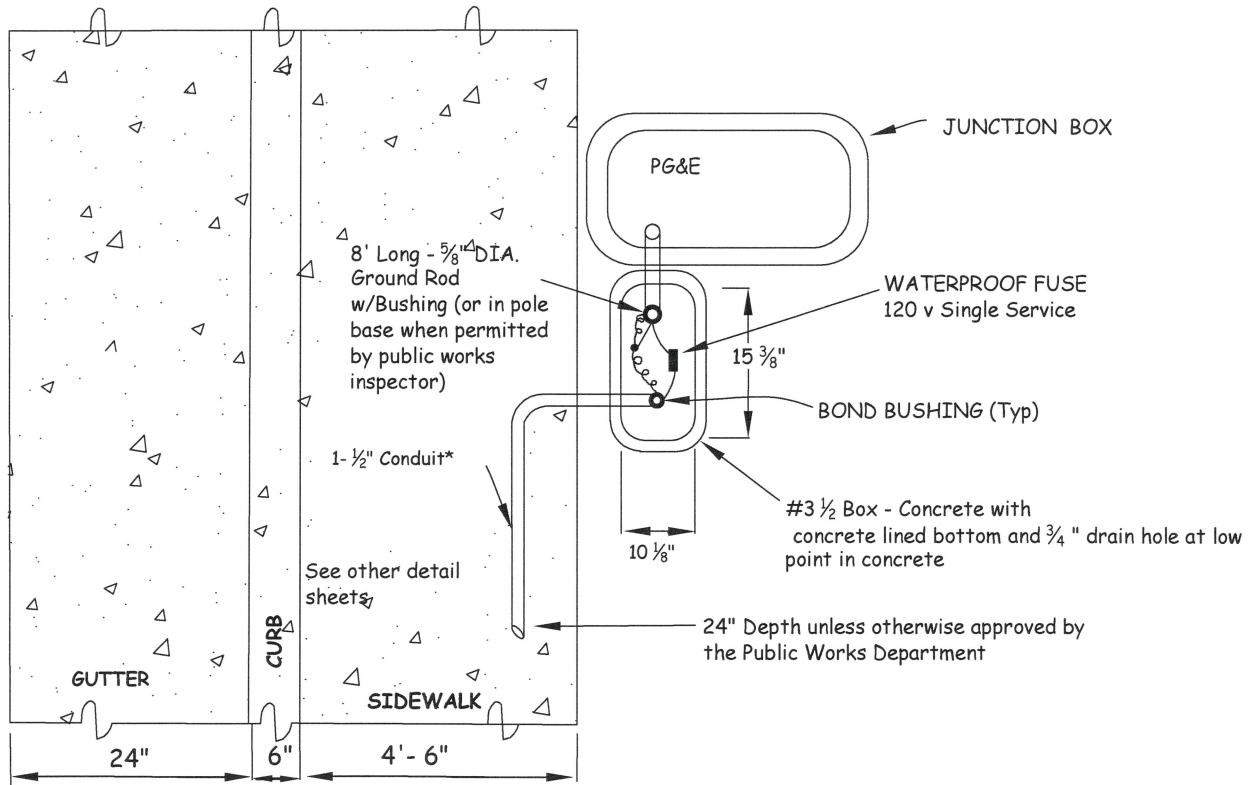

NOTES:

1. Conductors to be spliced in accordance with State Detail ES-13 "Pressure Connector" and "Waterproof"
2. See Lighting Notes (Detail 5-22)
3. Contact PG&E for additional information.
4. Fuses to be KTK-R type or equal.
5. Color code wires per State Specification.
6. Feeder conductors are to be a #8 min. with THW insulation
7. Contact U.S.A. prior to doing any work.
8. 8' - 5/8" diameter copper ground rod with bushing shall not be placed less than 6" to other grounding rods.
9. PVC Schedule 40 electrical type shall carry a separate grounding wire size of conductors.

SERVICE DETAIL

CITY OF CUPERTINO LIGHTING NOTES:

1. Luminaires, junction boxes, 1 ½" rigid metal conduit, 1 ½" PVC conduit, and poles shall comply with Section 86 of the Caltrans Standard Specifications (latest edition) and City Standard Details unless otherwise noted.
2. Luminaires may be cut off, Type M-II or M-III I.E.S. light distribution, unless otherwise noted. At cul-de-sacs M-III or better is required unless otherwise noted. See the plans.
3. The electrolier arm length shall be twelve feet (12') for forty foot (40') street widths with sidewalks, eight feet (8') for forty foot (40') street widths without sidewalks, and shall be fifteen feet (15') at cul-de-sacs. See plans for other applications.
4. The service supplying any electrolier circuit shall be fused and grounded in accordance with National Electrical Code at the first junction box. An additional fuse is required at each electrolier on any ungrounded conductor. Conductors shall be #8 THW unless otherwise noted and all services should be 120V. Photo electric unit control is to be at luminaire unless otherwise noted.
5. The electrical contractor shall obtain a service point confirmation and a clearance from Public Works Department prior to installing any foundations, poles, conduits, and conductors. Also, U.S.A. shall be used to verify locations of other utilities.
6. Prior to placing any work other than curb and gutter, the developer shall supply the Public Works Department with a Pacific Gas and Electric Company electrical power design with electrical services points and pole numbers.
7. A Public Works Department connection order is required to energize any electrolier. A connection order is provided by the City of Cupertino after completion and inspection for submittal to PG&E.
8. Contact Pacific Gas & Electric Company for additional requirements and contact Public Works Department for inspection of foundations forty eight (48) hours prior to foundation pouring, and electrical inspection.
9. The electrical contractor shall supply to the City for approval, manufacturer's submittals on all Luminaires. Induction is the City Standard. Wattage as directed by engineer. Typical wattage shall be 40W on residential roads, 120 W on major collectors and 150 W at signalized intersections.
10. Street lights are to be installed, inspected and turned on as soon as possible.
11. All conductors shall be sized in accordance with the National Electrical Code.
12. All overload protection (fuses) shall be sized in accordance with the National Electrical Code.
13. Whenever a new installation is near any overhead wires, a clearance must be obtained from PG&E prior to foundation installations.
14. Conduit depth to be 18" (min) to 24" (max) unless otherwise approved by the City Engineer.

CITY OF CUPERTINO TREE PROTECTION REQUIREMENTS:

1. Prior to any construction operations contractor shall construct and maintain, for each protected tree on a construction site, protective fencing which encircles the outer limits of the Tree Protection Zone (TPZ). The TPZ is calculated to be a radius of 6 times the diameter of the tree's trunk measured 4.5 feet above the natural grade, or as otherwise approved by the Director of Public Works.
2. All protective fencing shall be in place prior to commencement of any site work and remain in place until all exterior construction activity at the site has been completed.
3. Protective fencing shall be at least four (4) feet high, clearly visible, affixed to 2 inch galvanized posts driven into the ground no less than 8' on center, and shall have a tree protection sign affixed to the fence every twenty (20) feet in such a manner to be clearly visible and legible to workers on the site at a distance of twenty-five (25) feet. The sign(s) shall read "Keep Out Tree Protection Zone".
4. Install a 5-inch layer of mulch within the TPZ to aid in retaining moisture
5. Trees shall be kept well watered, especially during dry summer months. A long, slow soak over the entire root zone is the preferred method of watering. Frequent, shallow watering should be avoided, and water should not be directed at or near the trunks of trees.
6. The Contractor shall cause the required fencing and signage to be installed and maintained for the duration of the construction.
7. In situations where a protected tree remains in the immediate area of intended construction and the tree may be in danger of being damaged by construction equipment or other activity, the contractor or subcontractor shall protect the tree with 2"x4" lumber encircled with wire or other means that do not damage the tree. The intent is to protect the trunk of the tree against incidental contact by large construction equipment.
8. Material Storage: No storage or placement of materials intended for use in construction or waste materials accumulated due to excavation or demolition shall be placed within the limits of the TPZ of any protected tree.
9. Equipment Cleaning/Liquid Disposal: No equipment shall be cleaned or other liquids, including, without limitation, paint, oil, solvents, asphalt, concrete, mortar or similar materials shall be deposited or allowed to flow into the TPZ of a protected tree.
10. Tree Attachments: No signs, wires or other attachments, other than those of a protective nature, shall be attached to any protected tree.
11. Vehicular Traffic: No vehicular and/or construction equipment traffic or parking shall take place within the TPZ of any protected tree other than on existing street pavement.
12. No heavy equipment, including but not limited to trucks, tractors, trailers, bulldozers, excavators, skid steer tractors, trenchers, compressors, and hoists, shall be allowed inside the TPZ of any protected tree on any construction site.
13. Grade Changes: No grade changes shall be allowed within the limits of the TPZ of any protected tree unless adequate protective construction methods are approved in advance in writing by the city.
14. Impervious Paving: No paving with asphalt, concrete or other impervious materials shall be placed within the limits of the TPZ of a protected tree.
15. Root Pruning: Any roots two inches or larger in diameter which are exposed as a result of trenching or other excavation and which are permitted to be cut shall be cut off square with a sharp medium tooth saw and covered with natural fiber burlap within two hours of initial exposure.
16. All public sidewalks shall remain open, free and clear for public access, unless closure is permitted by the Public Works Department.

- Note:
- 1- See Tree Protection Requirements (Detail 6-2) for additional tree protection requirements.
 - 2- If there is no existing irrigation, see Tree Protection Requirements for watering requirements.
 - 3- No pruning shall be performed except by approved arborist.
 - 4- Use of this detail in lieu of Detail 6-4 may only be acceptable where installation of fencing will restrict ingress and egress of public streets, sidewalks or pathways that are to remain open. Approval by the Director of Public Works, or his or her designee, is required prior to use of this standard.

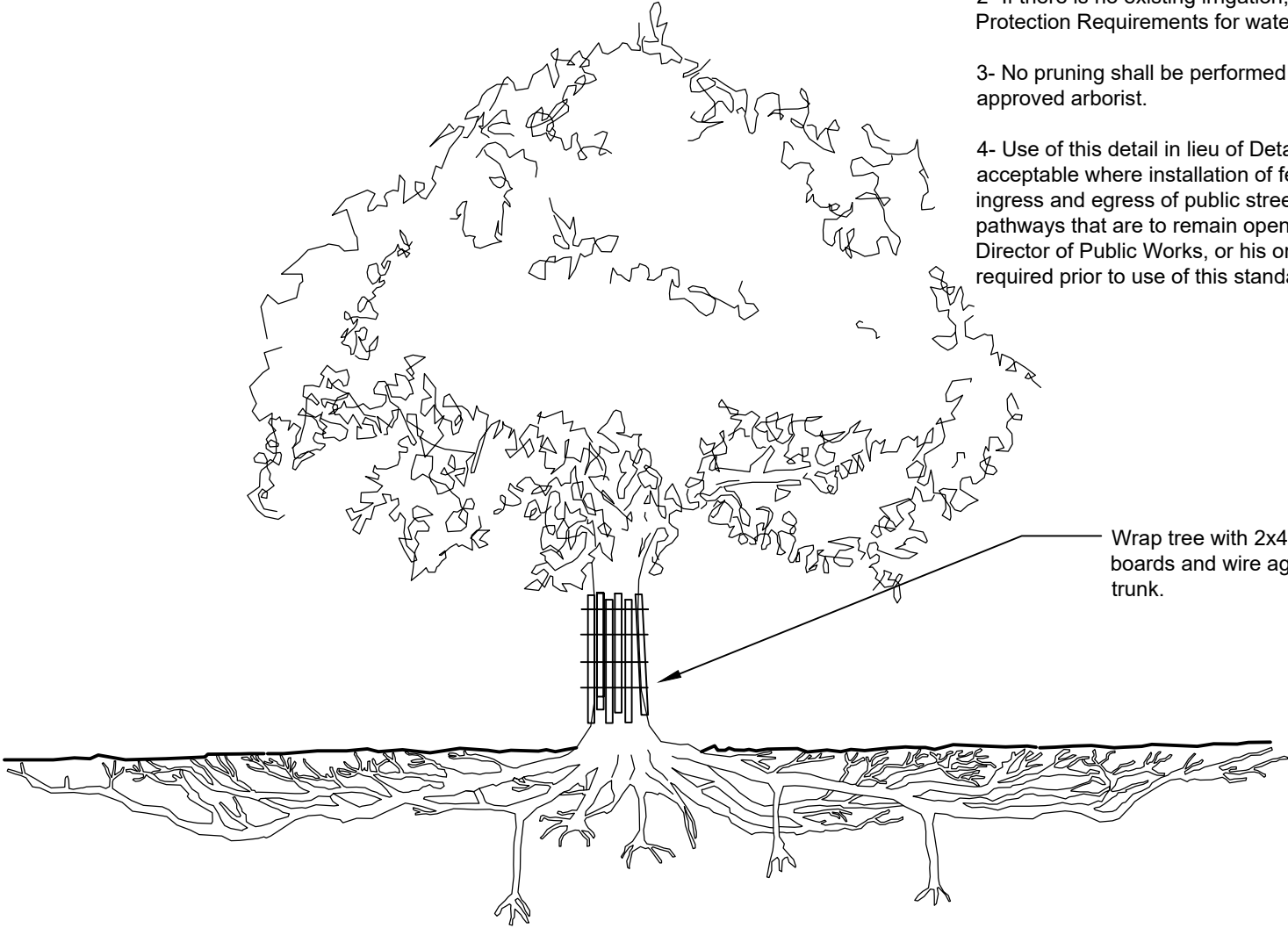

Wrap tree with 2x4 boards and wire against trunk.

CITY OF CUPERTINO
STANDARD DETAIL

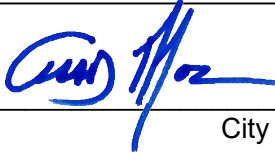
Approved By  Date 5/27/2020
City Engineer

6-3

Tree Protection Area shall be 6 times the DBH of the tree in all directions from the face of the trunk.

Notes:

- 1- See Tree Protection Requirements (Detail 6-2) for additional tree protection requirements.
- 2- If there is no existing irrigation, see Tree Protection Requirements for watering requirements.
- 3- No pruning shall be performed except by an approved arborist.
- 4- No equipment shall operate inside the protective fencing including during fence installation and removal.
- 5- Any modification must be approved by the Director of Public Works.

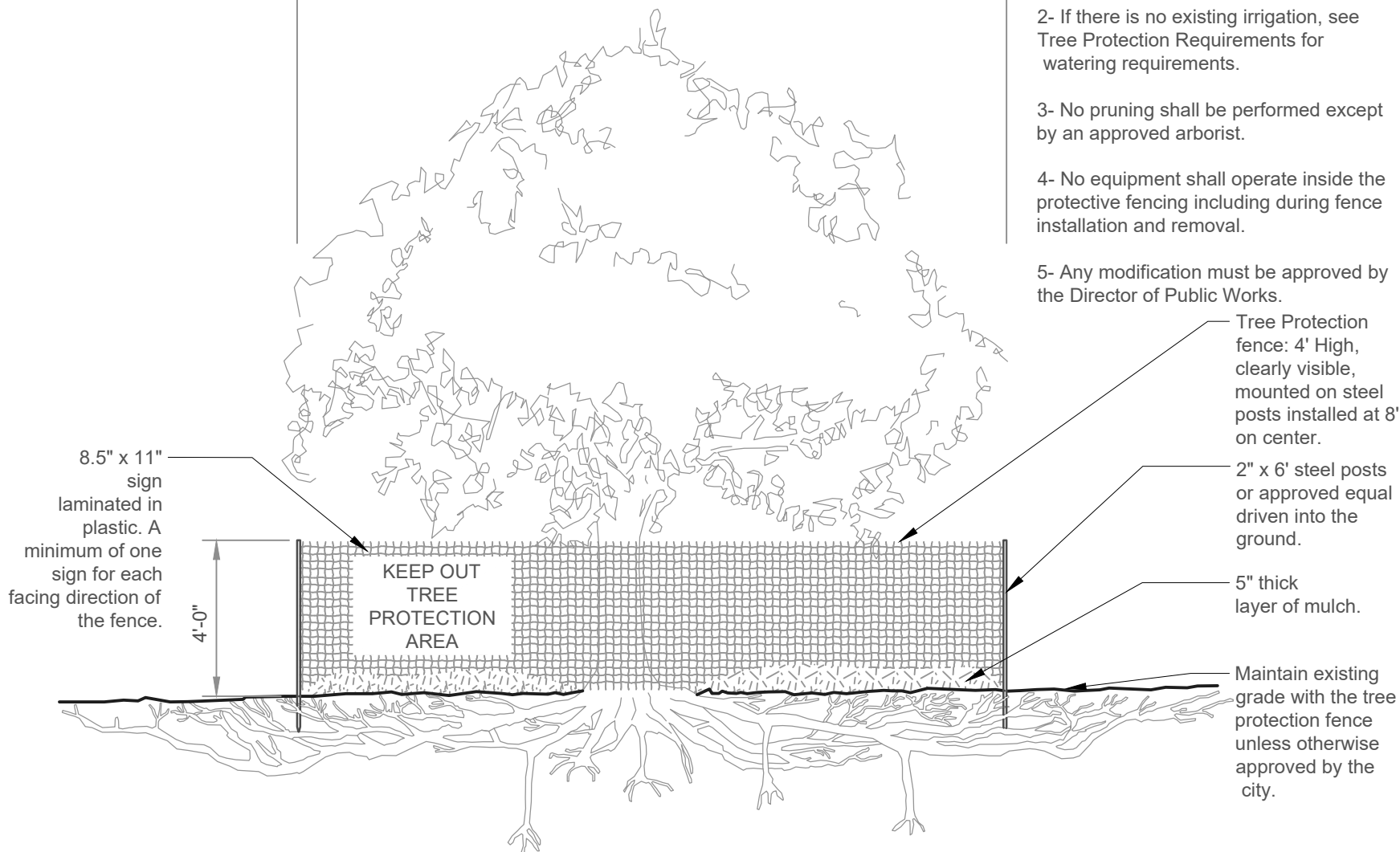

City of Cupertino
Standard Detail

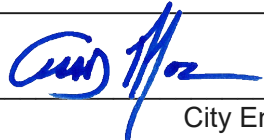
Approved By  City Engineer

Date 5/27/2020

6-4

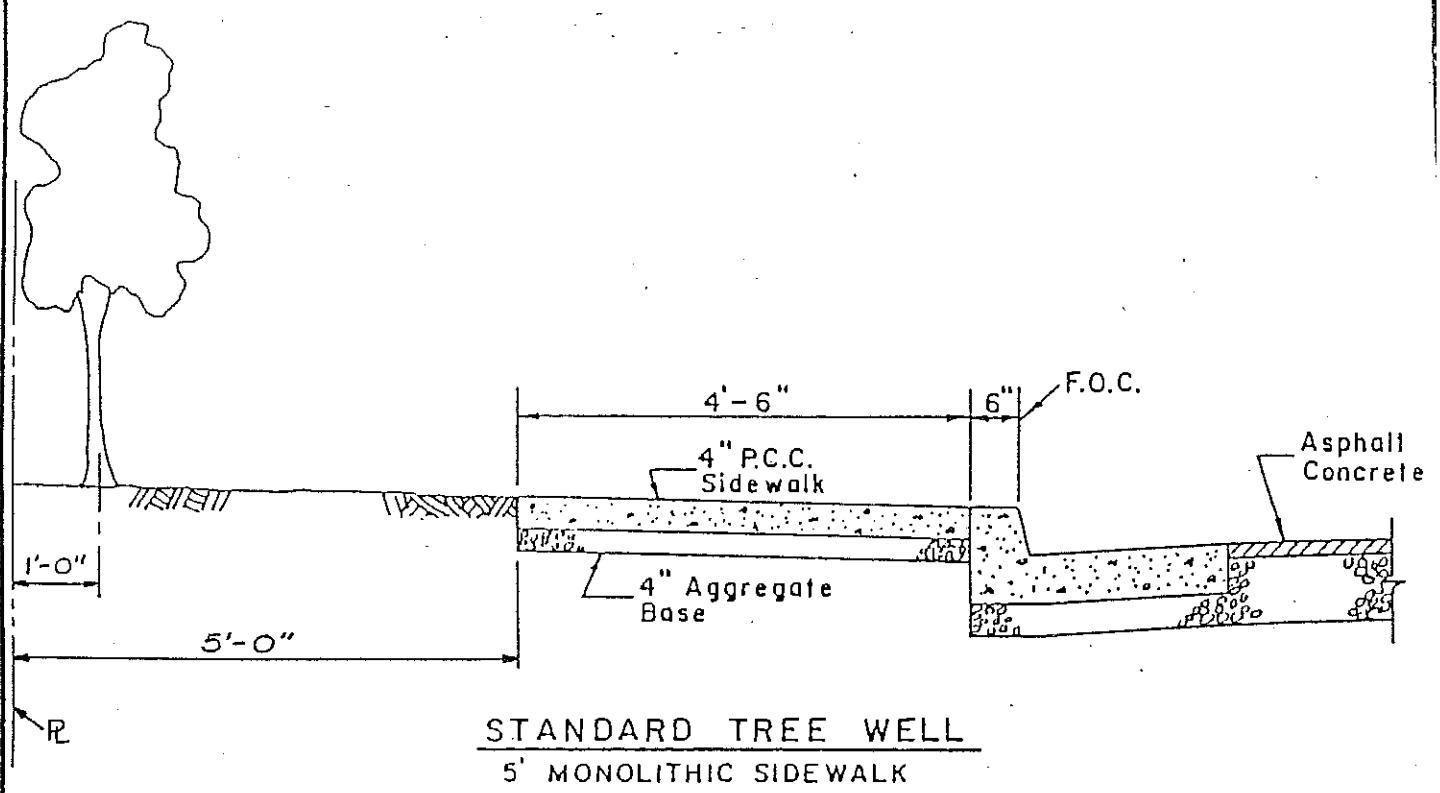

STANDARD TREE WELL
5' MONOLITHIC SIDEWALK

STREET TREE PLANTING REQUIREMENTS:

1. TREE SPACING 40' MIN TO 60" MAX.
2. PLANT 25' MIN. FROM B.C.R AT INTERSECTIONS.
3. PLANT 10' MIN. FROM EDGE OF DRIVE APPROACH.
4. PLANT 10' MIN. FROM UTILITY AND SEWER LINES.
5. PLANT 21' MIN. FROM STREET LIGHT STANDARDS.
6. PLANT 18' MIN. FROM POWER POLES.
7. PLANT 10' MIN. FROM FIRE HYDRANTS.
8. 4'-6" x 6' TREE WELL STANDARD, UNLESS OTHERWISE SPECIFIED

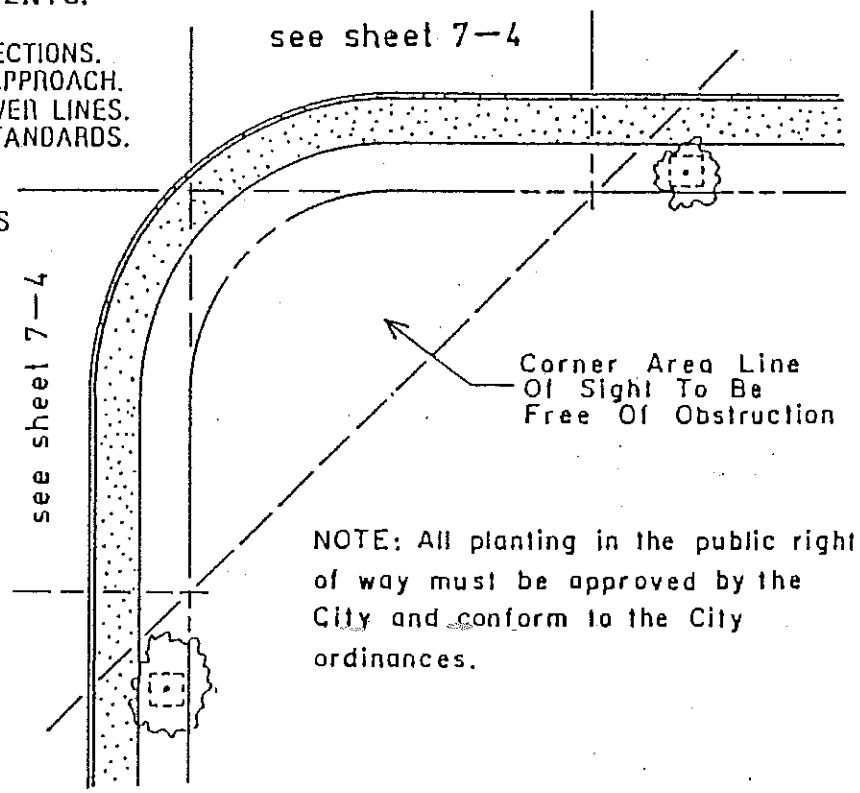

TREE PLANTING IN PUBLIC RIGHT OF WAY

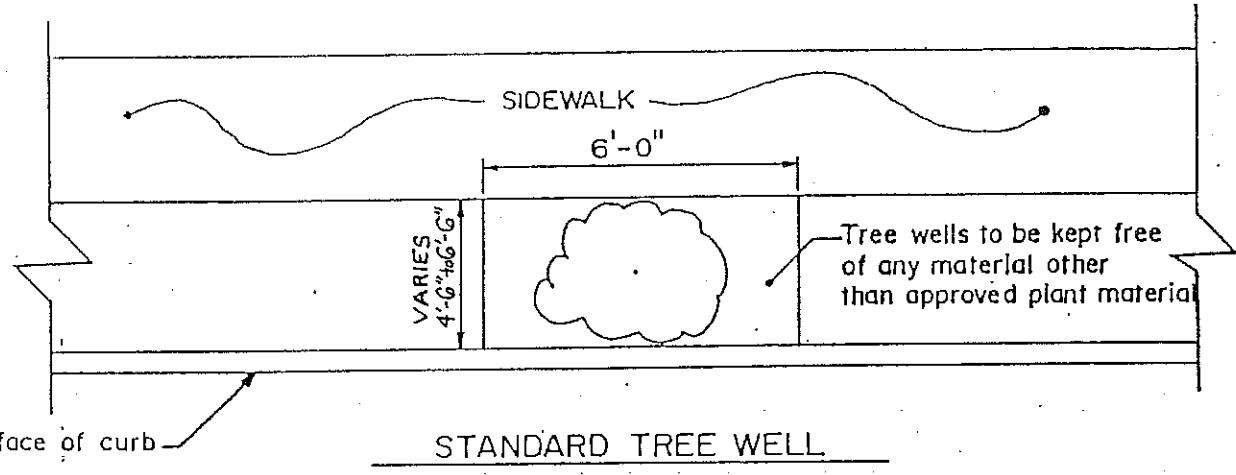
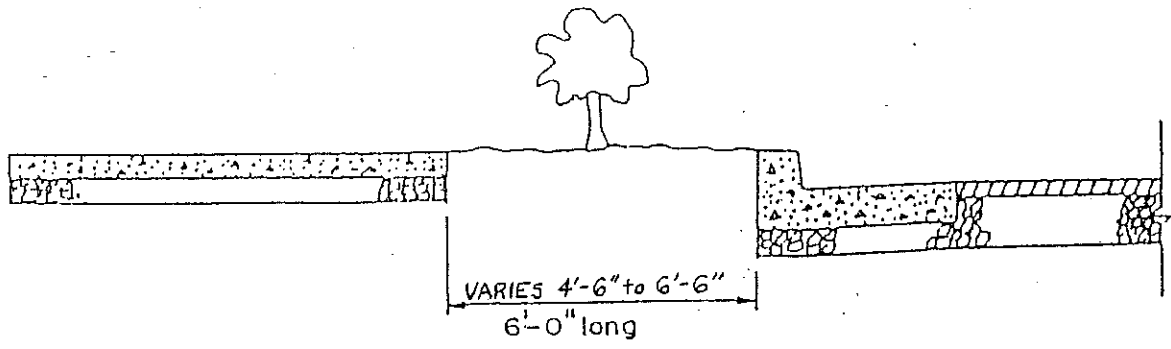

STANDARD TREE WELL

STREET TREE PLANTING REQUIREMENTS:

1. TREE SPACING 40' MIN TO 60' MAX.
2. PLANT 25' MIN. FROM D.C.R. AT INTERSECTIONS.
3. PLANT 10' MIN. FROM EDGE OF DRIVE APPROACH.
4. PLANT 10' MIN. FROM UTILITY AND SEWER LINES.
5. PLANT 21' MIN. FROM STREET LIGHT STANDARDS.
6. PLANT 10' MIN. FROM POWER POLES.
7. PLANT 10' MIN. FROM FIRE HYDRANTS.
8. 4'-6" x 6' TREE WELL STANDARD, UNLESS OTHERWISE SPECIFIED

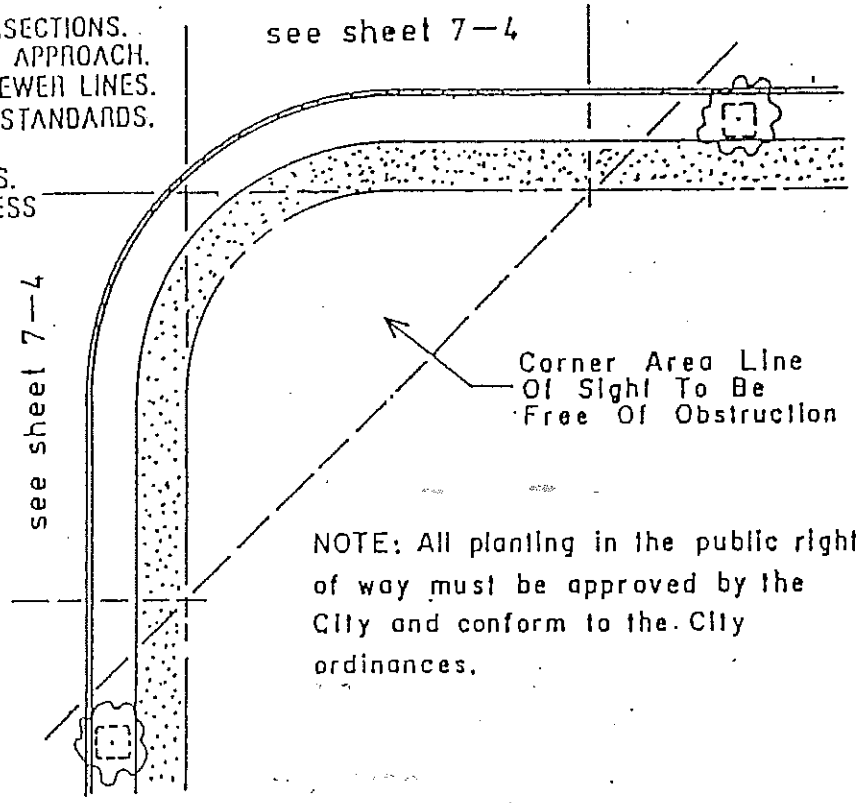

TREE PLANTING IN PUBLIC RIGHT OF WAY

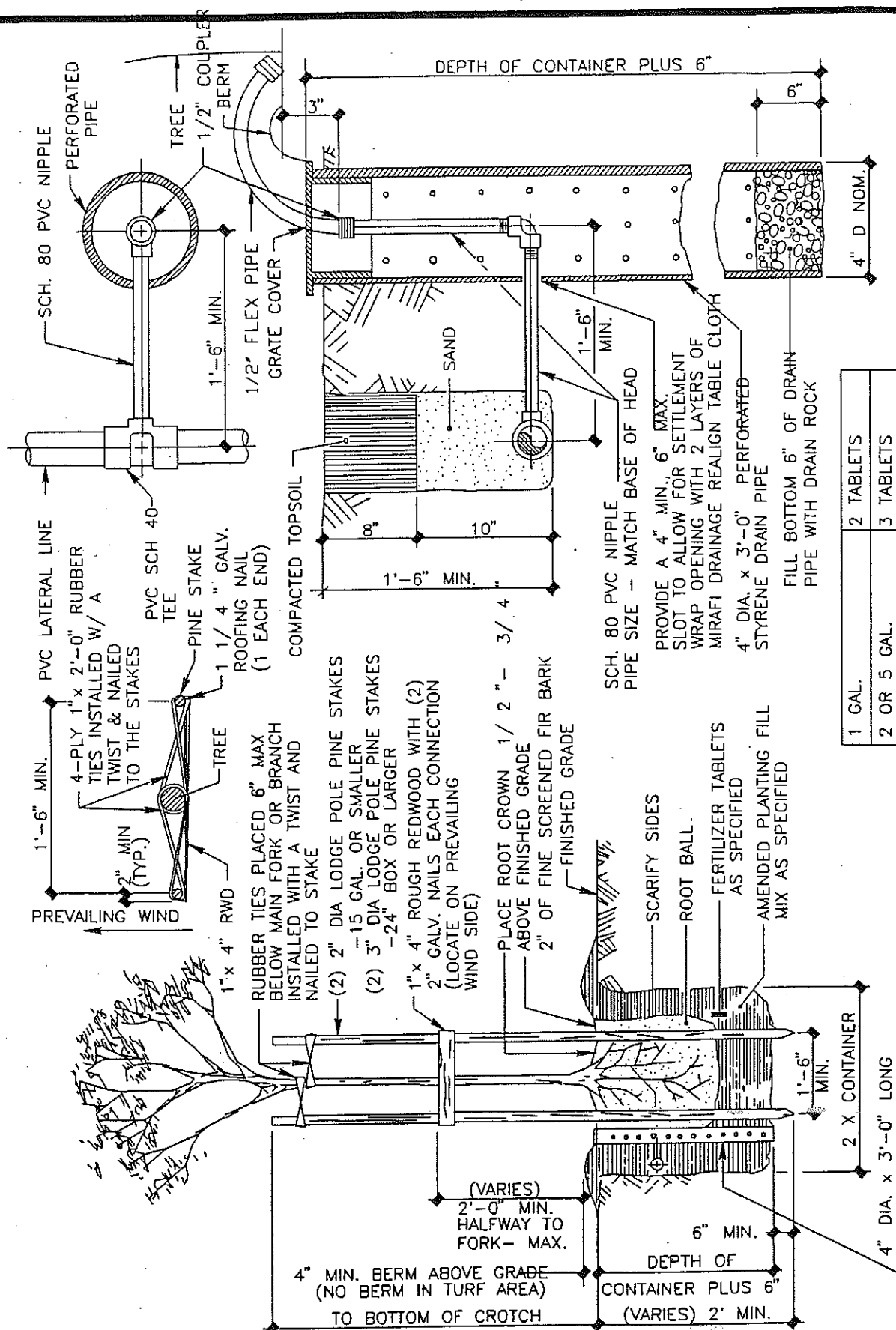

BUBBLER DETAIL

1 GAL.	2 TABLETS
2 OR 5 GAL.	3 TABLETS
15 GAL.	6 TABLETS
24" BOX OR LARGER	10 TABLETS

FERTILIZER

NOTES:
 1. USE 2 PIPES IN CONCRETE CUT-OUT AREAS. PUT PIPE ON UPHILL SIDE OF TREE. LEVEL SITE NORTH OF TREE.

TREE PLANTING WITH BUBBLER IRRIGATION

CORNER SIGHT DISTANCE

DESIGN 85 th PERCENTILE SPEED	SD
25	275
30	330
35	385
40	440
45	495
50	550

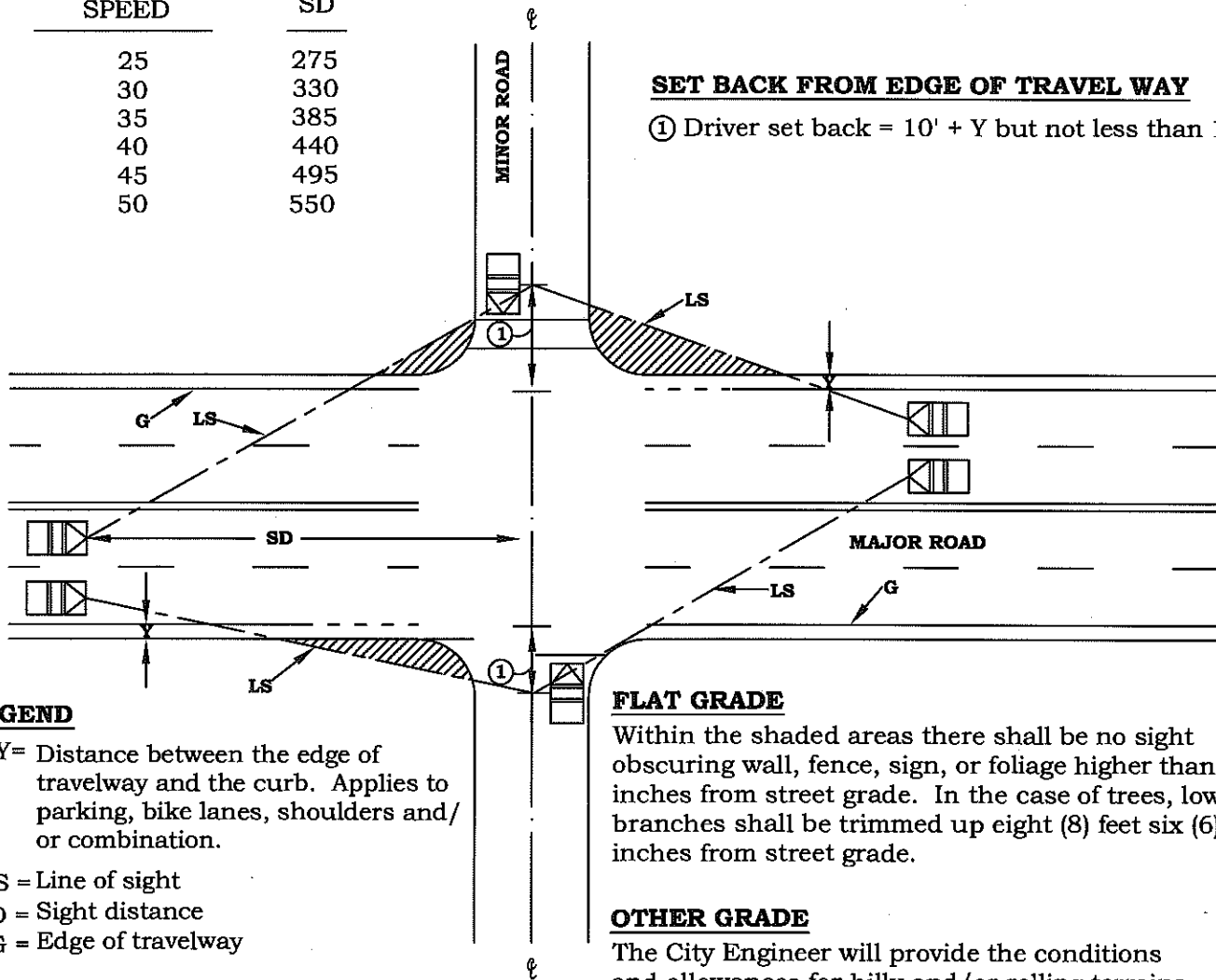

SET BACK FROM EDGE OF TRAVEL WAY

① Driver set back = 10' + Y but not less than 15'

LEGEND

Y = Distance between the edge of travelway and the curb. Applies to parking, bike lanes, shoulders and/or combination.

LS = Line of sight

SD = Sight distance

G = Edge of travelway

FLAT GRADE

Within the shaded areas there shall be no sight obscuring wall, fence, sign, or foliage higher than 42 inches from street grade. In the case of trees, lower branches shall be trimmed up eight (8) feet six (6) inches from street grade.

OTHER GRADE

The City Engineer will provide the conditions and allowances for hilly and/or rolling terrains.

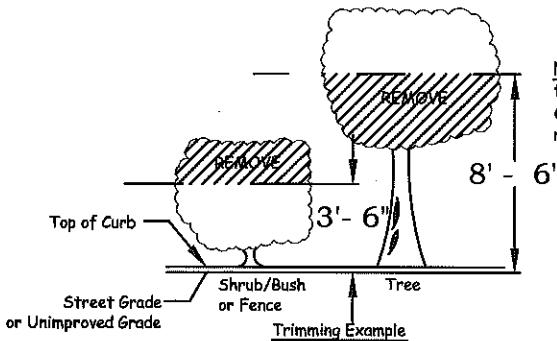

Note: Street trees shall be trimmed by City staff only. Call 408-777-3269 to request service.

Note: If no curb/gutter exist, the measurement is 3' from existing grade.

CONTROLLED INTERSECTIONS

FLAT GRADE

Within the shaded areas there shall be no sight obscuring wall, fence, sign, or foliage higher than 42 inches from street grade. In the case of trees, lower branches shall be trimmed up eight (8) feet six (6) inches from street grade.

OTHER GRADE

The City Engineer will provide the conditions and allowances for hilly and/or rolling terrains.

LEGEND

LS = Line of sight

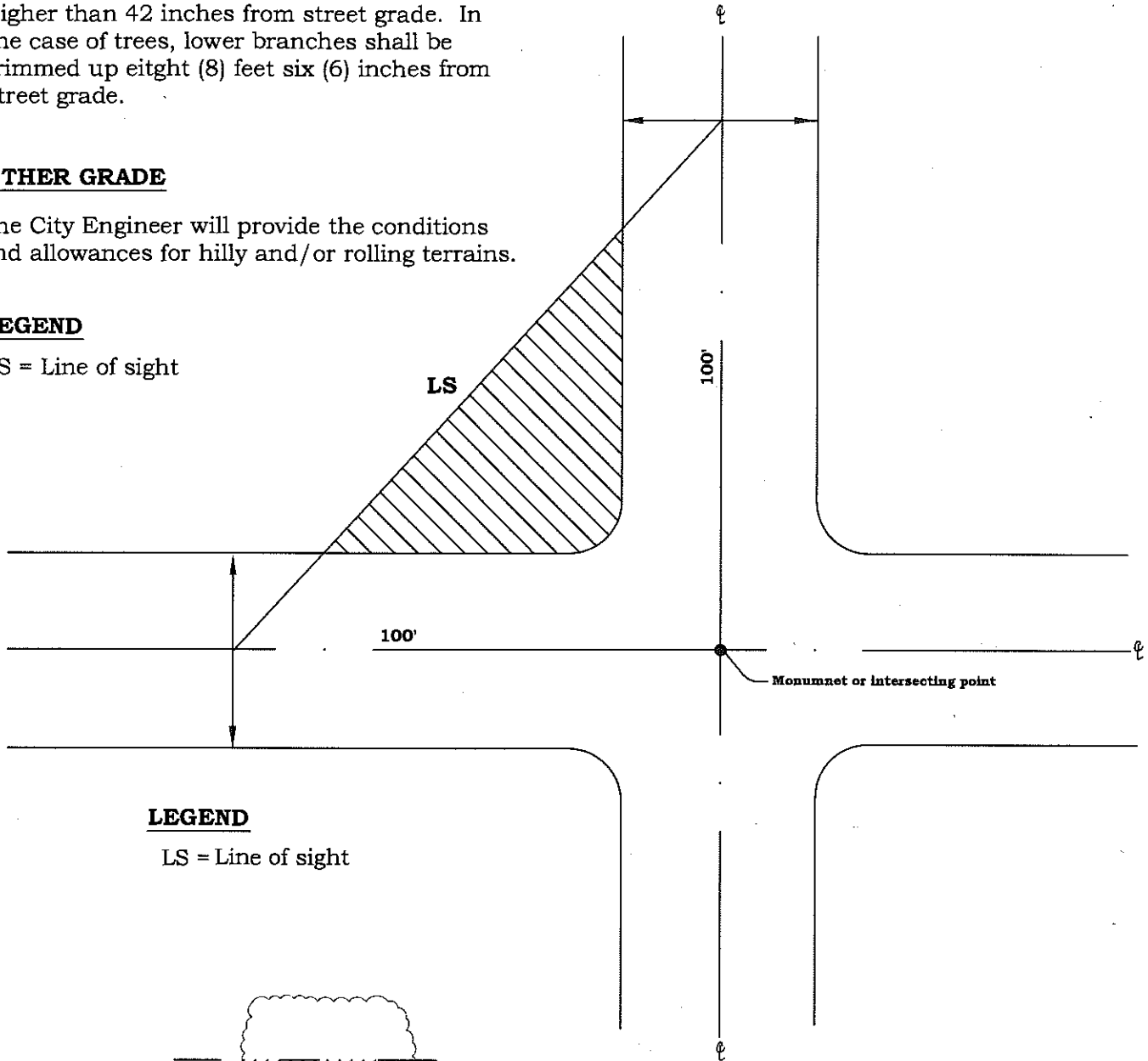

LEGEND

LS = Line of sight

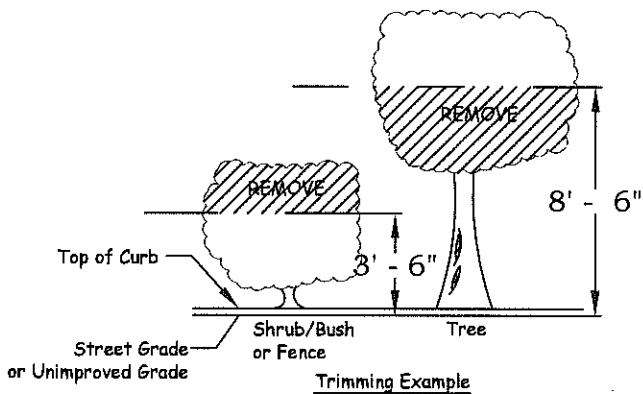

Note: Street trees shall be trimmed by City staff only. Call 408-777-3269 to request service.

Note: If no curb/gutter exist, the measurement is 3' from existing grade.

UNCONTROLLED INTERSECTIONS

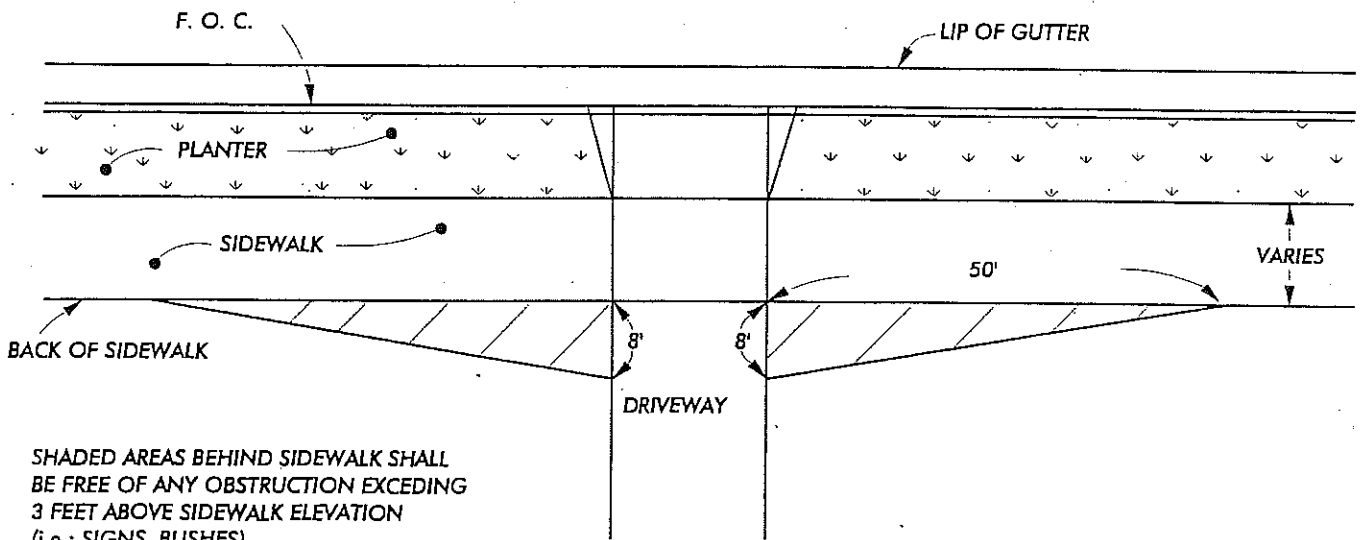

SHADED AREAS BEHIND SIDEWALK SHALL BE FREE OF ANY OBSTRUCTION EXCEEDING 3 FEET ABOVE SIDEWALK ELEVATION (i.e.: SIGNS, BUSHES). ALSO SEE DETAIL 7-2 (CONTROLLED INTERSECTIONS) FOR FURTHER RESTRICTIONS.

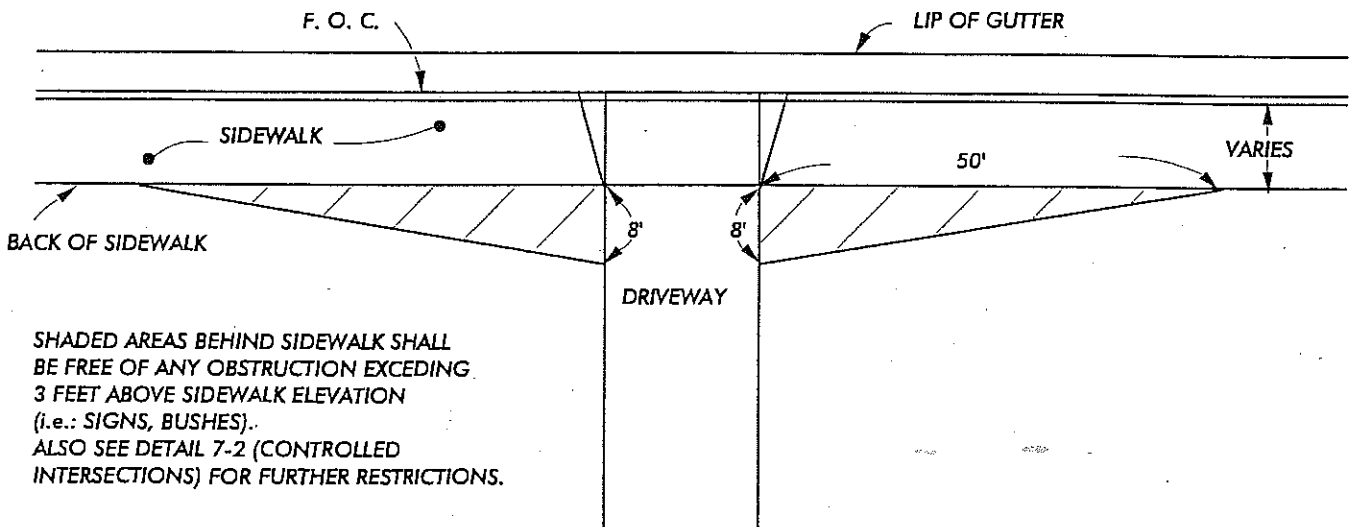

SHADED AREAS BEHIND SIDEWALK SHALL BE FREE OF ANY OBSTRUCTION EXCEEDING 3 FEET ABOVE SIDEWALK ELEVATION (i.e.: SIGNS, BUSHES). ALSO SEE DETAIL 7-2 (CONTROLLED INTERSECTIONS) FOR FURTHER RESTRICTIONS.

SIDEWALK CLEARANCE AT DRIVEWAYS

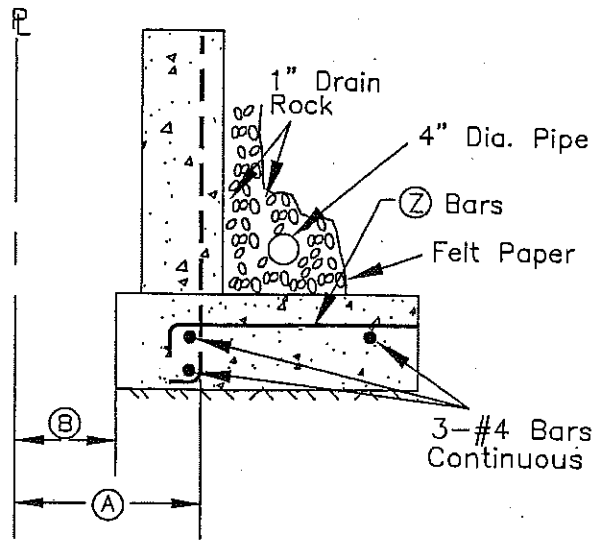
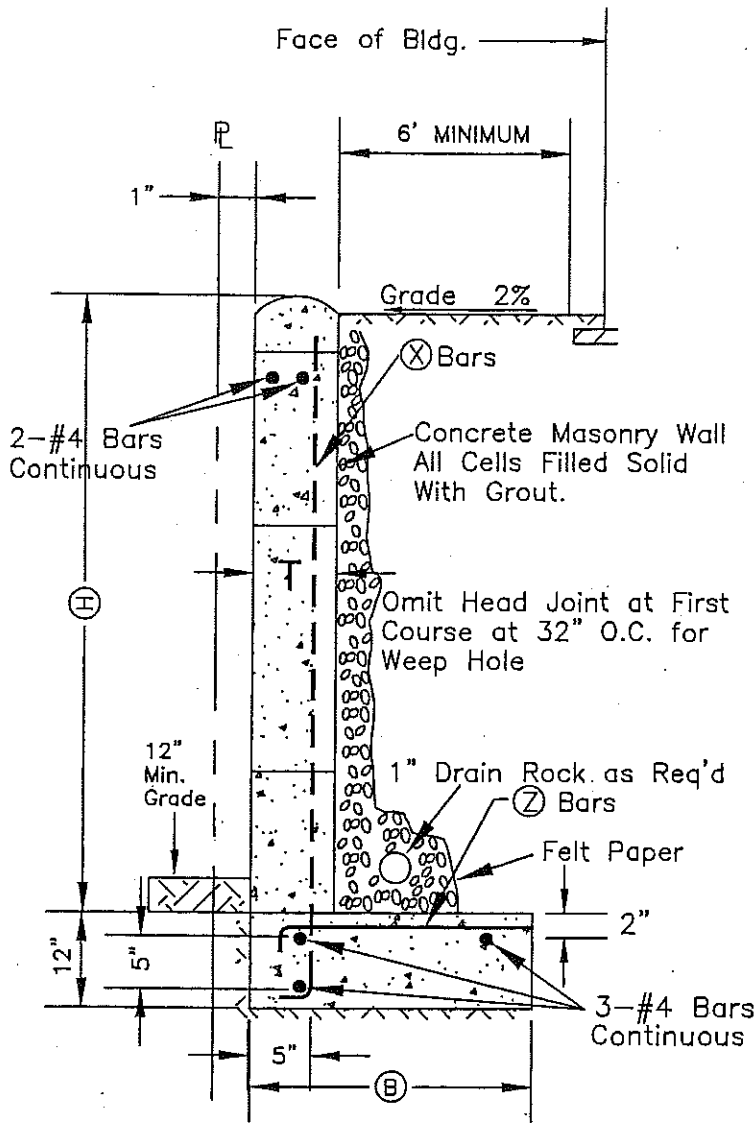

NOTE: Drains are required on ALL walls.

	A	B
PUBLIC R/W	3	1.5
ADJACENT PROPERTY	1.5	0.5

Pour Footing Against Undisturbed Natural Soil

RETAINING WALL GREATER THAN 3' HIGH SHALL BE DESIGNED BY A CIVIL/STRUCTURAL ENGINEER.

SPECIFICATIONS:
 GRADE "N" MASONRY UNITS
 TYPE = "M" or "S" GROUT
 GRADE = 40 STEEL
 E.F.P. = 30 #/FT³
 LATERAL SIDING = .35

⊕	⊖	⊗	⊙
3'max.	6"	1'-10"	#4 at 18"
			#4 at 48"

NOTES:

- Contact Public Works Department for Permit Requirements.
- Plans indicating Top of Wall (T.W.) Elevation, Existing and Finished Grades are required on all Retaining Wall Permits.

CONCRETE BLOCK RETAINING WALLS

REVISED 7/5/00

CITY OF CUPERTINO
STANDARD DETAILS

APPROVED BY:

[Signature]
CITY ENGINEER

DATE: 7/9/2000

8-2

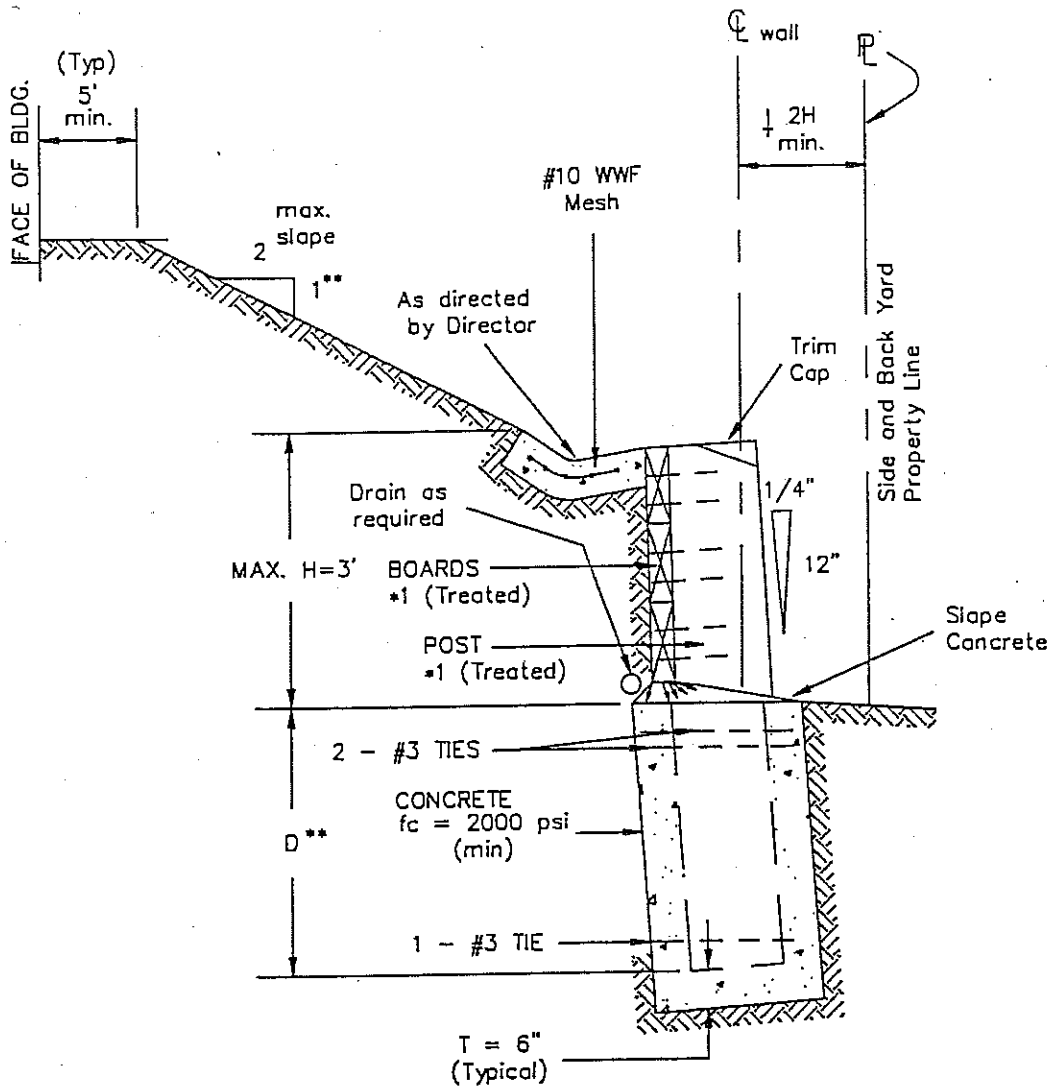

CROSS SECTION

H FT.	D** FT.	POSTS SIZE	MAX. SPACING	BOARDS SIZE
3	3	8" x 8"	6'	2' x 12"
2	2	6" x 6"	6'	2' x 12"
1	1	6" x 6"	6'	2' x 12"

- NOTES:
- *1. PRESERVATIVE TREATMENT (CREOSOTE or EQUAL) IN ACCORDANCE WITH SECTION 58, STANDARD SPECIFICATIONS (STATE OF CALIFORNIA, DEPARTMENT OF TRANSPORTATION, CURRENT EDITION).
 - **2. IF CERTIFIED BY SOILS ENGINEER.
 - ‡3. BLOCK WALL IS REQUIRED IF WALL IS WITHIN 2 x H FROM PROPERTY LINE (P).

TIMBER RETAINING WALL

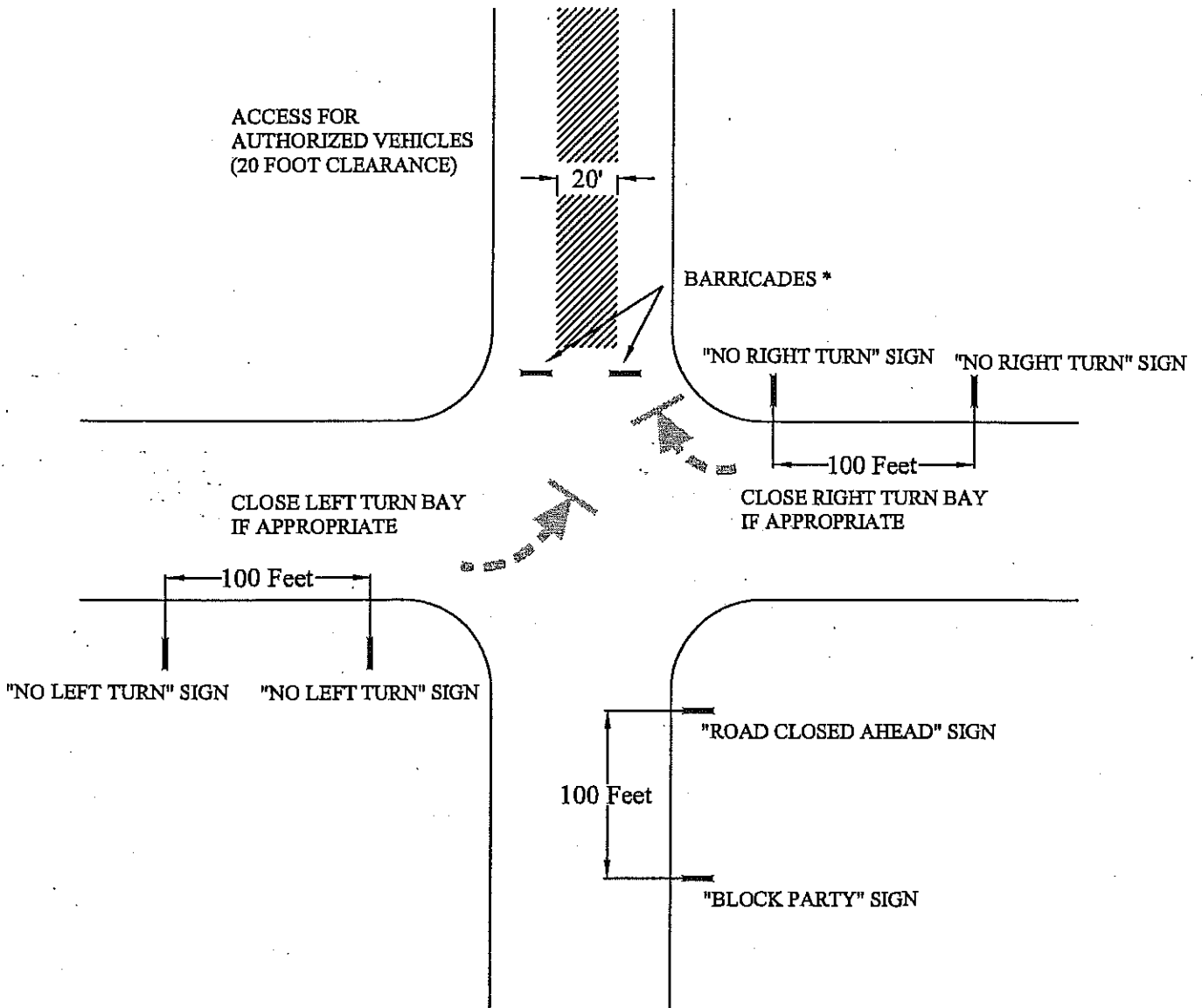

* BARRICADES WITH "ROAD CLOSED" AND "BLOCK PARTY" SIGNS
 (PERMITTEE SHALL POST A COPY OF THE INSURANCE & PERMIT AT EACH
 APPROACH CLOSED)

NOTES:

1. CITY SHALL FURNISH ALL BARRICADES AND SIGNS.
2. BLOCK PARTY PERMITTEE SHALL MAINTAIN
 A 20 FOOT CLEARANCE PATH IN THE TRAVEL WAY
 AT ALL TIMES.

LEGEND:

▬ BARRICADE W/SIGN

TYPICAL CLOSING OF BLOCK

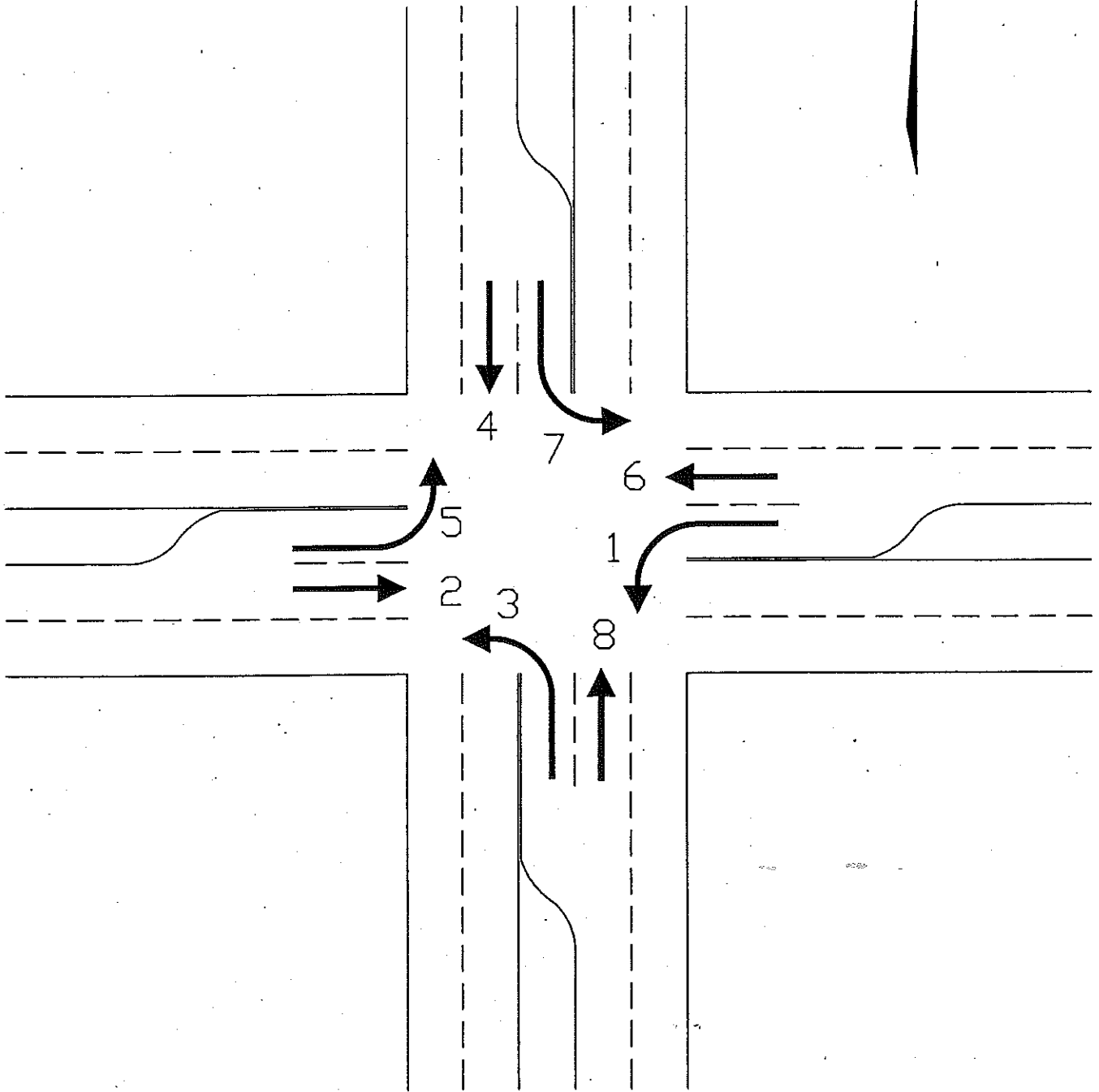
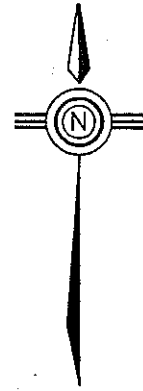

TRAFFIC SIGNAL PHASING

CITY OF CUPERTINO
STANDARD DETAILS

APPROVED BY:

[Signature]
CITY ENGINEER

DATE:

1/5/99

8-8

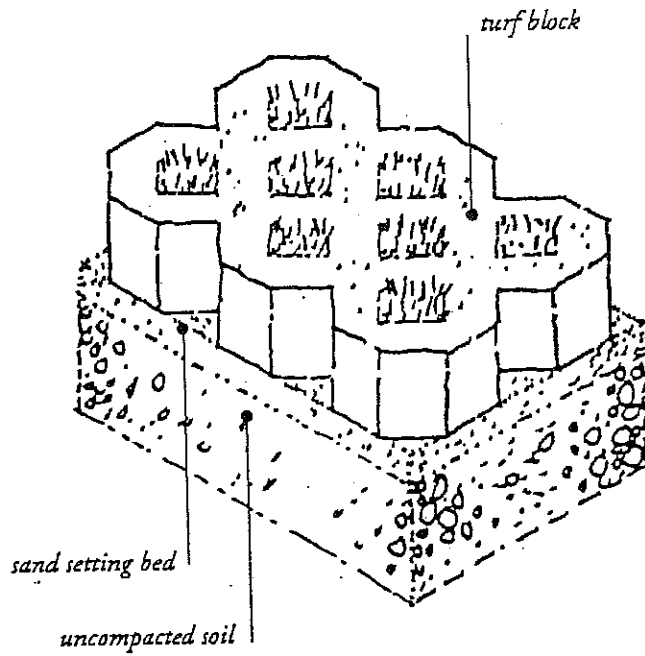

NOTES:

1. SHALL BE USED ONLY ON OVERFLOW PARKING AREAS, DRIVEWAYS, AND EMERGENCY ACCESS ROADS.
2. TYPES OF PLANTS/TURFS SHALL BE APPROVED BY PLANNING DEPARTMENT.
3. SHALL MEET MINIMUM WHEEL LOADING CAPACITY. OWNER TO PROVIDE SPECIFICATIONS.

TURF BLOCK

1. Bury the top end of the jute strip in a trench 6 in or more in depth.

2. Tamp the trench full of soil. Secure with row of staples: 6-in spacing, 4 in down from the trench.

3. Overlap: bury upper end of lower strip as in (1) and (2). Overlap end of top strip 4 in and staple.

See parking stall standards

4. Erosion stop: bury fold of jute in slit trench and tamp; staple double row of staples.

Overlap jute strips 4 in where two or more strip widths are required. Staple on 18-in centers.

See parking stall standards

Staple outside edge on 2-ft centers.

$S = 0.02 \text{ MAX}; 0.01 \text{ MIN.}$

Typical staples
No. 11 gauge wire

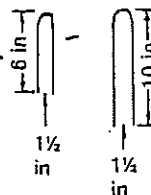

Tree planting is required at 25' o.c.

- Finish grade shall match flow line and not prevent run-off from draining.
- Type of tree shall be approved by Planning Department

GRASSED WATERWAYS WITH JUTE MAT

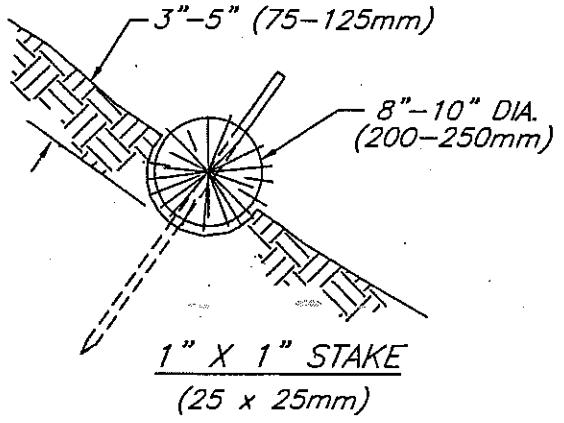
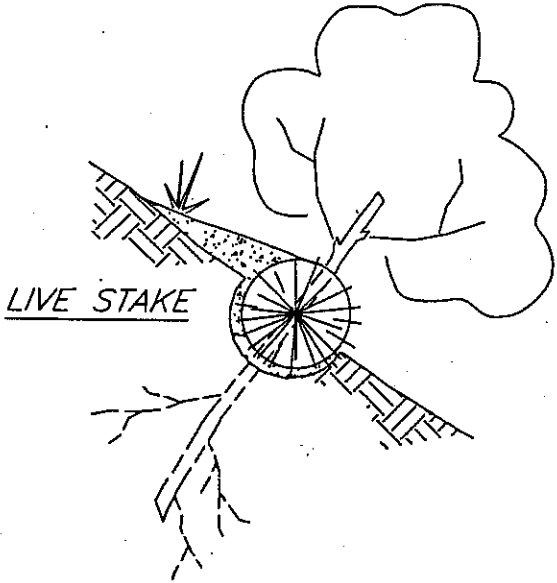
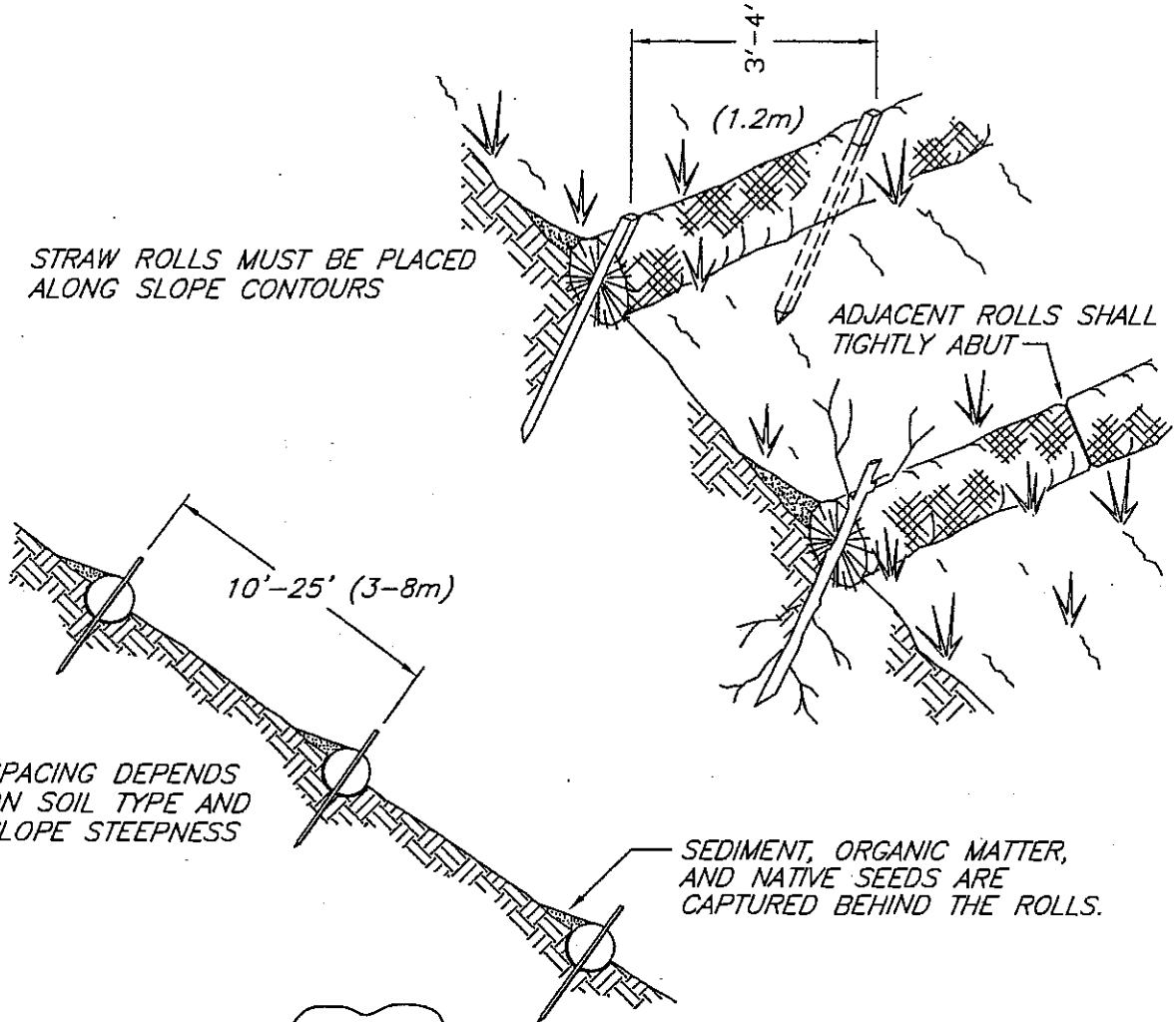

NOT TO SCALE

NOTE:
 1. STRAW ROLL INSTALLATION REQUIRES THE PLACEMENT AND SECURE STAKING OF THE ROLL IN A TRENCH, 3"-5" (75-125mm) DEEP, DUG ON CONTOUR. RUNOFF MUST NOT BE ALLOWED TO RUN UNDER OR AROUND ROLL.

STRAW ROLLS

© 1996 JOHN McCULLAH

FILE: STRWROLL