



PUBLIC WORKS DEPARTMENT • 10300 TORRE AVENUE • CUPERTINO,
CALIFORNIA 95014

TECHNICAL SPECIFICATIONS

FOR THE
CAPITAL IMPROVEMENT PROGRAMS'
**All-Inclusive Playground
at Jollyman Park Project**

MARCH 28, 2024

**00 01 10
TABLE OF CONTENTS**

(ALSO SEE CITY OF CUPERTINO PROJECT MANUAL)

DIVISION 1 – GENERAL REQUIREMENTS

01 57 13 TEMPORARY EROSION AND SEDIMENT CONTROL

DIVISION 2 – EXISTING CONDITIONS

02 41 00 DEMOLITION

DIVISION 3 – CONCRETE

03 00 00 LANDSCAPE CAST-IN-PLACE CONCRETE

03 20 00 CONCRETE REINFORCING

DIVISION 5 – METALS

05 50 00 METAL FABRICATIONS

DIVISION 11 – EQUIPMENT

11 68 00 PLAYGROUND EQUIPMENT

DIVISION 12 – FURNISHINGS

12 93 00 SITE FURNISHINGS

DIVISION 13 – SPECIAL CONSTRUCTION

13 00 00 PREFABRICATED RESTROOM BUILDING

DIVISION 22 – PLUMBING

22 11 16 DOMESTIC WATER PIPING

DIVISION 26 – ELECTRICAL

26 05 00 GENERAL REQUIREMENTS FOR ELECTRICAL SYSTEMS

26 05 19 LOW-VOLTAGE ELECTRICAL POWER CONDUCTORS AND CABLES

26 05 26 GROUNDING AND BONDING FOR ELECTRICAL SYSTEMS

26 05 33.13 CONDUIT FOR ELECTRICAL SYSTEMS

26 05 33.16 BOXES FOR ELECTRICAL SYSTEMS

26 27 26 WIRING DEVICES

DIVISION 31 – EARTHWORK

31 10 00 SITE CLEARING

31 20 00 EARTH MOVING

31 21 00 UTILITY TRENCHING AND BACKFILL

31 22 00 GRADING

DIVISION 32 – EXTERIOR IMPROVEMENTS

32 09 00 TEMPORARY TREE AND PLANT PROTECTION

32 11 00 BASE COURSES

32 13 00 RIGID PAVING

32 15 40 DECOMPOSED GRANITE PAVING

32 18 16 PLAYGROUND PROTECTIVE SURFACING

32 31 19 DECORATIVE METAL FENCES AND GATES

32 80 00 IRRIGATION

32 93 00 PLANTING

32 94 50 LANDSCAPE STONE

DIVISION 33 – UTILITIES

33 40 00 STORM DRAINAGE UTILITIES

33 46 00 BIORETENTION SUBDRAINAGE

SECTION 015713

TEMPORARY EROSION AND SEDIMENT CONTROL

PART 1 - GENERAL

1.1 SUMMARY

- A. Section Includes: requirements for temporary utilities, support facilities, storm water pollution prevention, erosion control, traffic control, support, and security and protection facilities.
- B. Related Requirements
 - 1. Refer to City of Cupertino Project Manual.

1.2 PRICE AND PAYMENT PROCEDURES

- A. Refer to City of Cupertino Project Manual.

1.3 WATER POLLUTION CONTROL PLAN

- A. Temporary Erosion and Sediment Control: Contractor shall implement and maintain temporary erosion and sediment control (Water Pollution Control Plan) for the project that shall conform to these special provisions, the Plans and the Bay Area Stormwater Management Agencies Association Blueprint for a Clean Bay.
- B. Water Pollution Control Plan Implementation: Contractor shall implement erosion and sediment control practices detailed in the Erosion Control and Sediment Control Field Manual, 3rd Edition and the California Stormwater Best Management Practices (BMP) Handbook, Construction, prepared by the California Regional Water Quality Control Board, San Francisco Bay Region.

1.4 EROSION CONTROL

- A. The project shall conform to the provisions listed in the City of Cupertino General Conditions.
- B. Temporary erosion and sediment control within the total project shall conform to the provisions in Section 21, Erosion Control, of the Caltrans Standard Specifications, these Special Provisions and the Plans.

PART 2 - PRODUCTS

2.1 BMP PRODUCTS

- A. Shall be as specified in the most current California Stormwater Quality Association (CASQA) BMP Handbook.

PART 3 - EXECUTION

3.1 WATER POLLUTION CONTROL PLAN

- A. Erosion and sediment control work shall consist of applying BMP's to control the discharge of stormwater pollutants in full compliance with the revised state regulations. BMP's shall be used to cover all temporary erosion and sediment control situations that arise during construction including unanticipated field conditions year-round. These erosion and sediment control measures shall control and contain erosion-caused silt deposits and provide for the safe discharge of silt-free storm water into existing and proposed storm drain facilities.
- B. Contractor shall implement and maintain all Water Pollution Control Plan work for the project that shall include:
 - 1. Prohibition of illicit discharge (non-rain water) into the storm drainage system.
 - 2. Construction of any and all necessary systems to eliminate contaminants from entering the storm water system.
 - 3. Clean up and control of work site materials, spoils and debris.
 - 4. Removal of contaminants produced by equipment used for the construction of the project.
 - 5. Provision of all labor, materials, equipment and apparatus not specifically mentioned herein or noted on the plans, but which are incidental and necessary to complete the work specified.
- C. Contractor shall be responsible for ensuring that all sub-contractors, and suppliers are aware of all storm water quality measures and that they implement such measures. Failure to comply with the stormwater quality regulations and specifications will result in the issuance of correction notices, citations and/or a project stop order.
- D. Contractor shall maintain erosion and sediment control measures daily. The name of the person responsible for the daily maintenance of these facilities shall be on record with the City of Cupertino Department of Public Works along with a phone number where they can be reached twenty four (24) hours a day.

3.2 EROSION AND SEDIMENT CONTROL

- A. Temporary erosion and sediment control work shall consist of applying erosion control materials to embankment slopes, excavation slopes and other areas designated on the plans, installing silt fence, inlet protection, gravel bags, headwall protection and stabilized construction entrance ways, or other measures as specified in the project or necessary for compliance with the Construction General Permit(CGP).

3.3 EMERGENCY EROSION AND SEDIMENT CONTROL

- A. Shall consist of any measures that the City's Representative deems necessary for compliance with the CGP including, but not limited to all erosion control measures necessary to prevent degradation to water quality.
- B. Sediment Control including unforeseen measures not addressed in the Storm Water Pollution Plan pay item in accordance with the National Pollution Discharge Elimination System (NPDES), the City of Cupertino and the Plans and Specifications and to the satisfaction of the City's Representative.

END OF SECTION

SECTION 024100

DEMOLITION

PART 1 - GENERAL

1.1 SUMMARY

- A. Section Includes: All labor, materials, equipment, tools, accessories, transportation, and services as required for Demolition. This work shall consist of measures that may or may not be shown on the plans to remove existing surface improvements and underground utilities encountered during construction of the improvements.
- B. Project Includes
 - 1. Demolition
 - 2. Disconnection, capping, and removal of utilities.
 - 3. Notification to Engineer of schedule of shut-off of utilities which serve occupied spaces.
 - 4. Removal and legal disposal of materials.
- C. Related Requirements
 - 1. Refer to City of Cupertino Project Manual
 - 2. Section 311000, Site Clearing
 - 3. Section 312200, Grading

1.2 PRICE AND PAYMENT PROCEDURES

- A. Refer to City of Cupertino Project Manual.

1.3 REFERENCES

- A. Reference Standards
 - 1. ANSI A10.6 Safety Requirements for demolition operations.
 - 2. City of Cupertino General Conditions
 - 3. Geotechnical Report: Geotechnical Evaluation, Jollyman Park All-Inclusive Playground, Ninyo & Moore Geotechnical & Environmental Sciences Consultants, February 18th 2022.

1.4 ADMINISTRATIVE REQUIREMENTS

- A. Coordination: Coordinate continued occupancy and accessibility of adjacent building, and other portions of the site.
- B. Meetings: Prior to commencing the work, Contractor shall perform a site review with the Engineer to determine the exact extent of this portion of work to identify existing areas of damage to existing items to remain.

- C. Provide a minimum of forty-eight (48) hours advance notice to Engineer of demolition activities. Do not begin demolition activities until receipt of notification to proceed from Engineer.
- D. Do not commence demolition activities until temporary erosion and sediment control measures are in place.

1.5 SUBMITTALS

- A. Record Documentation: Accurately record actual locations of capped and active utilities and subsurface construction. Submit record drawings to Engineer.
- B. Schedule
 - 1. Contractor shall submit a schedule indicating proposed methods and sequence of operations for selective demolition work. Schedule shall include coordination for shut-off, capping, and continuation of utility services as required. See Section 013000, Administrative Requirements.

PART 2 - PRODUCTS

2.1 MATERIALS

- A. Fill Materials: Shall be as specified in Section 312200, Grading.

PART 3 - EXECUTION

3.1 EXAMINATION

- A. Hazardous Materials: If hazardous materials are discovered during demolition activities, stop work and notify the Engineer immediately.

3.2 PREPARATION

- A. Protection of In-Place Conditions
 - 1. Surrounding areas, surfaces and appurtenances already in place shall be protected during demolition.
 - 2. Provide temporary barricades and other forms of protection as required to protect general public from injury due to selective demolition work.
 - 3. Provide protective measures as required to provide free and safe passage of general public to and from occupied portion of park.
- B. Surface Preparation: All work on this project shall conform to the Geotechnical Report.

3.3 DEMOLITION

- A. All deleterious material shall be removed and cleared from the site. See City of Cupertino General Conditions.
- B. Selective Demolition: Perform selective demolition work in a systematic manner. Use methods required to complete work indicated on the drawings in accordance with demolition schedule and governing regulations. Conduct selective demolition operations and debris removal in a manner to ensure minimum interference with roads, streets, walks, and other adjacent occupied or used facilities. Perform demolition with a manner that maximizes salvaged and recycling of materials.
 - 1. Dismantle existing construction and separate materials.
 - 2. Set aside reusable, recycled, and salvaged materials; store and deliver to collection point or point of reuse.
 - 3. All items so indicated on drawings shall be carefully removed and returned to the City storage yard as directed by the Engineer to facilitate possible reuse by the City.
- C. Contractor Salvage: Items indicated to be removed but of salvageable value to the Contractor may be removed from structure as work progresses. Transport Contractor salvage items from site as they are removed. Storage or sale of removed items on site will not be permitted.
- D. Extent: Demolish walls and footings to a depth of not less than twelve inches (12") below finish grade. Demolish and remove below-grade wood or metal construction. Break up below grade concrete slabs. Completely fill below-grade areas and voids resulting from demolition work. Provide fill consisting of approved earth, gravel or sand, free of trash and debris, stones over 6 inch diameter, roots or other organic matter.
- E. Partial Removal of Paving and Curbs: Neatly saw cut at right angle to surface.

3.4 REPAIR

- A. Damages: Promptly repair damage by demolition work caused to adjacent facilities at no additional cost to the City.
- B. Fill excavations, open pits, and holes in ground areas generated as result of removals, using specified fill; compact fill as required per Section 312200, Grading.

3.5 CLEANING

- A. Remove debris, rubbish and other materials resulting from demolition operations from building site. Transport and legally dispose of materials off site. Leave site in clean condition, ready for subsequent work.

END OF SECTION

SECTION 032000
CONCRETE REINFORCING

PART 1 - GENERAL

1.1 SUMMARY

- A. Section Includes: All labor, materials, equipment, tools, accessories, transportation, and services as required for furnishing and placing reinforcing steel and welded wire fabric reinforcing for concrete structures including roadway and pavement, as indicated.
- B. Related Requirements
 - 1. Section 321100, Base Courses
 - 2. Section 321300, Rigid Paving

1.02 PRICE AND PAYMENT PROCEDURES

- A. Refer to City of Cupertino Project Manual.

1.03 REFERENCES

- A. Reference Standards
 - 1. AISC, Specifications for Design, Fabrication, and Erection of Structural Steel for Buildings.
 - 2. American Welding Society, Code for Arc and Gas Welding, latest edition.
 - 3. Standard Specifications of the ASTM Latest Edition for Structural Steel for Buildings.
 - 4. ASTM A-615, Specification for Deformed and Plain Billet-Steel Bars for Concrete Reinforcement.
 - 5. ASTM A-706, Specification for Low Alloy Steel Deformed Bars for Concrete Reinforcement.
 - 6. City of Cupertino General Conditions
- B. Caltrans Standard Specifications, 2018
 - 1. Section 51: Concrete Structures
 - 2. Section 73: Concrete Curbs and Sidewalks
 - 3. Section 90: Concrete

1.04 ADMINISTRATIVE REQUIREMENTS

- A. Sequencing: Installation of concrete reinforcing shall occur prior to placement of concrete.

1.05 SUBMITTALS

- A. Certificates
 - 1. The Contractor shall provide Mill Certificates for reinforcing steel in accordance with the requirements of Section 013000, Administrative Requirements, of these specifications.

- a. The Contractor shall provide Mill Certificates for each size of bar for each heat to be used on project.
 - b. Mill Certificates shall include name of mill, date of rolling, date of shipping to fabricator and shall be signed by fabricator certifying that each material complies with or exceeds the specified requirements. A Mill Certificate shall be furnished with each lot of material delivered to the project and the lot shall be clearly identified in the Certificate.
- B. Shop Drawings: Location, spacing, and site of concrete reinforcement to be included in shop drawings as required bends, splices, and embedment length shall also be included in shop drawings.

1.06 QUALITY ASSURANCE

- A. Qualifications
1. Fabrication and welding shall be licensed operations.

PART 2 - PRODUCTS

1.07 CONCRETE REINFORCING

- A. Description
1. Materials and fabrication shall be in accordance with the standards as shown in Section 1.03A.
 2. Bars for reinforcement shall conform to the requirements of ASTM A706, Grade 60. No. 3 ties or spirals may conform to the requirements of ASTM A706 or A615, Grade 60.
 3. All other materials, not specifically described by these specifications but required for complete and proper placement of reinforcement shall be new, first quality of their respective kinds, and subject to the approval of the City's Representative.

1.08 SOURCE QUALITY CONTROL

- A. Tests and Inspections
1. Product Test Reports: Tests of reinforcing steel may be made by a Testing Laboratory approved by the City's Representative if requested by the City. The cost of the required tests shall be paid by the City. Three (3) copies of verified reports showing results on the tests shall be submitted to the City's Representative. Said reports shall state definitely whether or not materials tested conform to the aforementioned specifications and/or standards.
 - a. The Contractor shall cooperate with the Testing Laboratory making the required tests.
 - b. Laboratory test reports shall show the name of testing agency; date of testing, types of tests performed and shall be signed by a principal of the testing agency who is a registered Civil City's Representative in the State of California.
 - c. When required by other portions of these specifications, laboratory test reports shall be submitted for each size of bar tested for each heat to show compliance with appropriate ASTM Standards and these specifications.

PART 3 - EXECUTION

1.09 EXAMINATION

- A. Verification of Conditions: In the event conduits, pipes, inserts, sleeves, or any other items interfere with placing the reinforcement as indicated on the drawings or approved shop drawings, or as otherwise required, immediately notify the City's Representative and obtain approval on procedure before placement of reinforcement is started.
- B. Evaluation and Assessment
 - 1. All reinforcement, at the time concrete is placed, shall be free from rust, scale, oil, mortar, or other coatings that will destroy or reduce the bond.

1.10 PREPARATION

- A. Protection of In-Place Conditions
 - 1. Surrounding areas, surfaces and appurtenances already in place shall be protected during installation of concrete reinforcing.
- B. Cleaning Reinforcement
 - 1. Take all means necessary to ensure that steel reinforcement, at the time concrete is placed around it, is completely free from rust, dirt, loose mill scale, oil, paint and all coatings which will destroy or reduce the bond between steel and concrete.

1.11 INSTALLATION

- A. Placing Steel Reinforcement
 - 1. Bars shall be free of mortar, oil, dirt, excessive mill scale and scabby rust and other coatings of any character that would destroy or reduce the bond. All bending shall be done cold, to the shapes shown on the plans. The length of lapped splices shall be as follows:
 - a. Reinforcing bars No. 8, or smaller, shall be lapped at least 45 bar diameters of the smaller bar joined, and reinforced bars Nos. 9, 10, and 11 shall be lapped at least 60 bar diameters of the smaller bars joined, except when otherwise shown on the plans.
 - b. Splice locations shall be made as indicated on the plans.
 - 2. Accurately place reinforcement as shown on the plans and hold firmly and securely in position by wiring at intersections and splices, and by providing precast mortar blocks or ferrous metal chairs, spacers, metal hangers, supporting wires, and other approved devices of sufficient strength to resist crushing under applied loads. Provide supports and ties of such strength and density to permit walking on reinforcing without undue displacement.
 - 3. Place reinforcing to provide the following minimum concrete cover:
 - a. Surfaces exposed to water: 4 inches.
 - b. Surfaces poured against earth: 3 inches.
 - c. Formed surfaces exposed to earth or weather: 2 inches.
 - d. Slabs, walls, not exposed to weather or earth: 1 inch.
 - 4. Minimum spacing, center of parallel bars shall be two and one half (2 ½) times the diameter of the larger sized bar. Accurately tie reinforcing securely in place prior to pouring concrete. Placing of dowels or other reinforcing in the wet concrete is not permitted.
- B. Special Techniques

1. Welding shall conform to best modern practice, be of adequate strength, with jointing made tight and flush and in true planes.
 2. Bending: Bends for reinforcing steel shall be made in accordance with ACI 318 latest edition. Bend all bars cold. Do not field bend reinforcing steel in a manner that will injure material, cause the bars to be bent on too tight a radius, or that is not indicated as allowed on drawings or permitted by City's Representative. Do not straighten bent or kinked bars for use on project without permission of City's Representative.
 3. Placing of reinforcement shall conform to Concrete Reinforcing Steel Institute (CRSI), Placing Reinforcement Bars and ACI 301 as they apply to this project.
 - a. All reinforcement shall be placed in strict conformity with the requirements of the drawings, both as to location, position and spacing members. It shall be supported and secured against displacement by the use of adequate and proper wire supporting and spacing devices, tie wires, etc. so that it will remain in its proper position in the finished structure.
 - b. Preserve clear space between parallel bars of not less than one and one half (1-1/2) times the nominal diameter of round bars and in no case let the clear distance be less than one and one half inches (1-1/2") nor less than one and one third (1-1/3) times the maximum size of aggregate for concrete.
 4. Cutting: Bars shall not be cut by gas torch.
 5. Splicing shall be at least 40 bar diameters for reinforcing bars and six inches (6") for welded wire fabric.
 - a. All splices not shown on the Project Drawings shall be shown on the shop drawings and approved by the City's Representative.
 6. Unless otherwise noted, welding of crossing bars (tack welding) for assembly of reinforcement is prohibited.
 7. Support and fasten together all reinforcement to prevent displacement by construction loads or placing of concrete.
 8. Lifting of bars and welded wire fabric into position during placement of concrete is not permitted.
 9. Where the concrete surface will be exposed to the weather in the finished structure, the portions of all accessories within one half inch (1/2") of the concrete surface shall be non-corrosive or protected against corrosion.
 10. Provide minimum protective cover given in of ACI 318 if not indicated on Drawings.
 11. All embedment lengths not shown on the Project Drawings shall be shown on the shop drawings and approved by the City's Representative.
- C. Interface with Other Work
1. Jointing and intersections of metals shall be accurately made.

1.12 SITE QUALITY CONTROL

- A. Correction During Pouring: Capable steel setters shall be kept at the work site at all times during the placing of concrete and shall properly reset any reinforcement displaced by runways, workmen, or other causes.
- B. Non-Conforming Work
1. Defective Work: At the discretion of the City's Representative, all defective work shall be replaced at no extra cost to the City.

1.13 CLEANING

- A. Exposed reinforcing at construction joints shall be cleaned and/or bent at least twenty four (24) hours after concrete is placed.

END OF SECTION

SECTION 03 30 00

LANDSCAPE CAST-IN-PLACE CONCRETE

PART 1 - GENERAL

1.1 SUMMARY

- A. This section includes all labor, materials, equipment, etc., needed to complete the installation of site concrete work **in the All-Inclusive Playground scope** of the project, including base, reinforcing, color, finishes, etc., including, but not limited to, the following:
- Pedestrian and Vehicular paving (refer to Civil specification for concrete work in the ADA improvements scope)
 - Concrete curbs, thickened edge at pavement, integral curbs and mow bands
 - Stair with cheek walls
 - Seatwalls
 - Concrete wall with Chalk art finish
 - Concrete Transfer Curb
 - Sign footings, grab rail footing, sand play table footing.
 - Footings for Site furnishings (benches, tables, bike racks).
 - Footings for Vine Arch, Metal Fence and gates, Nature Retreat and Communication board

1.2 RELATED DOCUMENTS

- A. Refer to the City of Cupertino's project manual for general provisions of the Contract .
- B. The City Specifications for Concrete work shall take precedence over this section of the specifications, where the two are in conflict. Contact the City Representative whenever conflicts or questions arise, prior to proceeding with the work.
- C. Structural engineering requirements per drawings S0.01 and S0.02 for concrete work including. footings, Conc. Wall with Chalk finish and Interactive Art Feature.
- D. CIP concrete footings for play equipment detailed on drawings L3.06, L3.07, L3.08 to be provided as a deferred submittal for review and approval.
- E. Related Specification Sections

Section 321300 Rigid Paving (For CIP concrete paving, curbs, ADA ramps, driveways and misc. concrete items in the ADA Improvements scope)

Section 055000 Metal Fabrications (for stair handrails)

Section 116800 Playground-Equipment

Section 129300 Site-Furnishings

1.3 ADMINISTRATIVE REQUIREMENTS

A. Notification

1. Notify other crafts so they may deliver anchors, inserts, etc., or other material required to be embedded in concrete.
2. Notify the City's Representative in writing at least forty-eight hours in advance of each concrete placement. The City's Representative will notify the geotechnical engineer and testing laboratory to order out the necessary concrete technicians to cover the work.
3. Once the concrete technicians are ordered out and a cancellation follows, the Contractor will be charged \$300 dollars for each technician so ordered to appear, unless a cancellation order is issued to the Laboratory by 3:00 pm the day before the concrete placement.
4. During the placement of the concrete, notify the City's Representative immediately of any delay at the concrete plant or at the job site. Do not mix concrete or add admixtures unless the Technician is present as per the Building Code.
5. Before submitting design mixtures, review concrete design mixture and examine procedures for ensuring quality of concrete materials.

- B. Sequencing: The Contractor shall notify the City's Representative at least forty eight (48) hours prior to placing any concrete. No concrete shall be placed in any unit of work until all form work and shoring has been constructed and all reinforcements and items to be built into concrete have been placed and secured and approved by the City's Representative.

C. Preinstallation Meeting:

1. Require representatives of each entity directly concerned with cast-in-place concrete to attend the preinstallation conference at Project site, including the following:
 - a. Contractor's superintendent
 - b. Concrete Subcontractor and concrete finisher.
 - c. Geotechnical Engineer
 - d. Landscape Architect
 - e. Civil Engineer
 - f. City's Representative
2. Review special inspection and testing and inspecting procedures. Review methods and procedures related to concrete wall Work, footings and slab Work including, but not limited to, the following:
 - a. Extent and sequence of Work
 - b. Field quality control plan and responsibilities
 - c. Mockup requirements
 - d. Forms and form removal limitations
 - e. Shoring and reshoring procedures
 - f. Materials and timing to be applied and removed
 - g. Mix designs, test of mixes, and Submittals
 - h. Placement methods, techniques, equipment, consolidation, and form pressures
 - i. Slump and placement time to maintain slump
 - j. Concrete finishes and finishing
 - k. Cold and hot weather concreting procedures

- l. Curing procedures and curing times
- m. Construction, contraction and isolation joints and joint-filler strips
- n. Semi-rigid joint fillers
- o. Anchor rod and anchorage device installation tolerances
- p. Steel reinforcement installation
- q. Methods for achieving specified surface flatness and levelness
- r. Concrete repair procedures
- s. Concrete protection and adjacent surface protection

1.4 SUBMITTALS:

A. ACTION SUBMITTALS

1. Design Mixtures: Each concrete mix design to be used on the project shall be reviewed and approved by the Testing Agency and Landscape Architect prior to concrete being delivered to site. Submit proposed mix designs for each class of concrete on the Mix Design schedule included at the end of this specification. Submit alternate design mixtures when characteristics of materials, Project conditions, weather, test results, or other circumstances warrant adjustments.
 - a. For each concrete mixture the following information shall be included:
 - 1) Where the mix is to be used. (site diagram)
 - 2) All materials and admixtures including their source and proportions in the mix.
 - 3) Water content.
 - 4) Water to cement ratio. W/C
 - 5) Slump.
 - 6) Aggregate grading.
 - 7) Whether the mixture is appropriate for pumping.
 - 8) Total chloride content.
 - b. Provide shrinkage test results for mixes with shrinkage criteria showing that mix meets performance criteria. The mix design number must match with the mix design number shown on the test data.
 - c. Indicate compressive strength and method used to determine strength. The compressive strength of the concrete shall be proportioned per ACI. Include all calculations and tests required by ACI 318 Section 5.3 and 5.4. Laboratory test data must be submitted along with calculations that show each mix design meets the strength requirement. Mix design number must match the mix design number shown on the test data. Include all test results or past-history back up data specific as part of the submittal. Test results within the past two years shall be used to indicate performance in accordance with past-history.
 - d. Addition of water to the mix after leaving the plant is not permitted.
2. Formwork and Jointing Review: Submit as markups on the landscape plans, any deviations from the intended location and layout of pavement contraction and expansion joints. Indicate pour sequence and construction joints required for each separate pour.

3. Product Data for each type of project indicated: Manufacturer's catalog sheets including instructions for use and description of application shall be provided for each type of product indicated, including each of the following materials:
 - a. Epoxies
 - b. Grout
 - c. Admixtures
 - d. Curing Compounds
 - e. Chemical Hardener
 - f. Integral Colors
4. Do not order and deliver product to job site until submittal has been approved.

B. SAMPLES

1. Concrete color and finish samples:
 - a. For each concrete color and finish, a minimum 2' x 2' sample shall be poured and finished for approval by the City Representative prior to beginning concrete work.
 - 1) Light Broom finish (pavement and curbs)
 - 2) Smooth rubbed finish (wall with chalk art)
 - 3) Exposed aggregate surface retarder finish (seatwalls and transfer curb)
 - b. All approved samples shall be kept at the job site for comparison with finished work.
2. Joint sealant samples:
 - a. Submit to City Representative manufacturer's literature, specification data, and color sample for all materials proposed for the project (see section 2.7A).
 - b. Identify their use and location.

C. INFORMATIONAL SUBMITTALS

1. Material Test and Evaluation Reports:
2. Material test report for coarse aggregate for concrete mix.
3. Material test report for small aggregate for concrete mix.
4. Batch Tickets: For each concrete load delivered to the Project site submit copy of the delivery ticket in accordance with ASTM C 94 requirements, and in addition including, but not limited to the following:
 - a. Mix type and strength.
 - b. Each material in load with quantities by weight.
 - c. Water cement ratio.
 - d. Slump.
 - e. Integral color, type, brand, and amount, if specified.
 - f. Fiber reinforcement type, brand, and amount, if specified.
5. Pour Sequence Plan:
6. Pour Schedule
7. Field Quality Control
 - a. Test Reports showing compressive strength of concrete test cylinders taken upon delivery of concrete.
 - b. Testing Laboratory slip resistance test reports for exposed aggregate paving finish.

8. Manufacturer's Instructions:
 - a. Round dowel sleeve installation instructions.
 - b. Concrete paving installer qualification statement:
 - 1) List of at least 5 projects of successfully installed cast-in-place concrete paving with exposed aggregate finishes utilizing surface retarders and/or or washing using other etching solutions totaling at least 20,000 square feet.
 - 2) Accompany Landscape Architect an Owner representative on visits to completed projects, if considered necessary to review workmanship and finishes in person.
 - 3) Include project contact person and phone number of project architect and/or landscape architect.
 - 4) Include color photos for each listed project that represent overall quality of finish, joint craftsmanship, and paving edge craftsmanship.

1.5 QUALITY ASSURANCE

- A. Manufacturer Qualifications: A firm experienced in manufacturing ready-mixed concrete products and that complies with ASTM C 94 requirements for production facilities and equipment.
- B. Source Limitations: Obtain each type or class of cementitious material of the same brand from the same manufacturer's plant, obtain aggregate from one source, and obtain admixtures through one source from a single manufacturer.
- C. ACI Publications: Comply with the following unless modified by requirements in the Contract Documents:
 1. ACI 301, "Specification for Structural Concrete," Sections 1 through 5.
 2. ACI 117, "Specifications for Tolerances for Concrete Construction and Materials."
- D. Mockups: Provide mockups for the following to verify selections made under sample submittals, to demonstrate aesthetic effects and to set quality standards for materials and execution:
 1. Seatwalls: Provide 18"W x 16"H x 36"L section for each with top, face and edge treatment, reveals and exposed aggregate surface retarder finish.
 2. Chalk Art Wall: 12"W x full height as detailed x 36"L section for each with top, face and edge treatment, reveals and smooth rubbed finish.
 3. Concrete Paving: Build mockup of concrete paving not less than 8 feet by 8 feet to effectively demonstrate typical joints and joint patterns; surface color, light broom finish; curing; and standard of workmanship. Approved samples shall serve as standard for the color and finish for all subsequent concrete work for the project.
 4. Concrete curbs: Build (1) mockup of raised concrete curb 8 linear feet and (1) mockup of a flush concrete curb 8 linear feet, to effectively demonstrate typical joints; surface color, light broom finish; curing; and standard of

workmanship. Approved samples shall serve as standard for the color and finish for all subsequent concrete work for the project.

5. Note: Allow for a minimum of 7 days of curing prior to review for color and finish.
 6. Approved mock-ups shall serve as standard for the color and finish and quality of execution for all subsequent concrete work for the project.
 7. Approval of mockups does not constitute approval of deviations from the Contract Documents contained in mockups unless City Representative and Landscape Architect specifically approves such deviations in writing.
 8. Contractor shall meet or exceed the quality of the approved finish in all subsequent work.
 9. Protect accepted mockups from the elements with weather-resistant membrane.
 10. Contractor shall remove the mock-ups at completion of the work.
 11. Approved mockups may become part of the completed Work if undisturbed at time of Substantial Completion.
- E. Patching: Any surface requiring patching shall be reviewed with the City Representative, prior to proceeding with the work, and shall be consistent and matching with the adjacent and surrounding surface in color and finish.
- F. Pre-installation Conference: Conduct conference at Project site with the City Representative.
1. Review methods and procedures related to decorative concrete paving, including but not limited to, the following:
 - a. Concrete mixture design.
 - b. Quality control of concrete materials and decorative concrete paving construction practices.
 - c. Mockup samples.
- G. Layout of the Work: Layout and establishment of lines, levels, grades, and positions of all items that include concrete shall be done by a licensed surveyor or registered civil engineer. Obtain approval of layout by City Representative prior to installation.

2. PRODUCTS

2.1 FORM-FACING MATERIALS

- A. Smooth-Formed Finished Concrete: Form-facing panels that will provide continuous, true, and smooth concrete surfaces. Furnish in largest practicable sizes to minimize number of joints. The following list of materials

1. Masonite, coated plywood, steel, or other suitable material may be used provided form does not imprint concrete with grain or pattern.
 2. Plywood shall be free from loose knots, holes, and other defects, grade B-B concrete form panels conforming to PS-1.
 3. Surfaces of steel forms shall be free from irregularities, dents, and sags.
- B. Rough-Formed Finished Concrete (only below grade applications): Plywood, lumber, metal, or another approved material. Provide lumber dressed on at least two edges and one side for tight fit.
- C. Forms for Curves: Use flexible or uniformly curved forms for curves with a radius of 100 feet or less. Do not use notched, kinked and bent forms.
- D. Form-Release Agent: Commercially formulated form-release agent that will not bond with, stain, or adversely affect concrete surfaces and will not impair subsequent treatments of concrete surfaces.
1. Formulate form-release agent with rust inhibitor for steel form-facing materials.
- E. Form Ties: Factory-fabricated, removable or snap-off metal or glass-fiber-reinforced plastic form ties designed to resist lateral pressure of fresh concrete on forms and to prevent spalling of concrete on removal.
1. Furnish units that will leave no corrodible metal closer than 1 inch (25 mm) to the plane of exposed concrete surface.
 2. Furnish ties that, when removed, will leave holes no larger than 1 inch (25 mm) in diameter in concrete surface.
 3. Furnish ties with integral water-barrier plates to walls indicated to receive dampproofing or waterproofing.

2.2 STEEL REINFORCEMENT

- A. Epoxy-Coated, Joint Dowel Bars: ASTM A 775; with ASTM A 615, Grade 60 (Grade 420) plain-steel bars.
- B. Reinforcing Bars: ASTM A 615/ A 615M, Grade 60 deformed.
- C. Tie Bars: ASTM A 615/A 615M, Grade 60 deformed.
- D. Bar Supports: Bolsters, chairs, spacers, and other devices for spacing, supporting, and fastening reinforcing bars and welded wire reinforcement in place. Manufacture bar supports from steel wire, plastic, or precast concrete according to CRSI's "Manual of Standard Practice."

2.3 CONCRETE MATERIALS

- A. Mix Design: Mix designs shall be signed by a testing laboratory approved by the City Representative. Each design shall be verified by tests on cylinders prior to placement

of the concrete, and compression tests shall show values at least 25% greater than the minimum strength indicated or specified, per ACI Standards, at no additional cost to the project.

Strength:

- a. Pedestrian Section Paving. Flush bands, Raised curbs: 3,000psi at 28 days
 - b. Vehicular Section Paving: 4,000psi at 28 days
 - c. Concrete wall w/ Chalk Art finish, and Interactive Feature footing: Per structural Engineer's requirements on drawings S0.01 and S0.02.
 - d. Seat walls and Concrete Transfer curb: 3,000psi at 28 days
 - e. Footings 3,000psi min., at 28 days
 - 1) Slump: 4 in.
 - 2) Max. aggregate size: 3/4in.
 - 3) Min. Sacks of cement per cubic yard: 5.5
 - 4) Water/Cementitious Material Ratio (maximum): 40 percent by weight.
- B. Cementitious Material: Use the following cementitious materials, of same type, brand, and source throughout Project:
1. Portland Cement: ASTM C 150, gray portland cement Type II. Supplement with any or all of the following:
 - a. Fly Ash: ASTM C 618, Class F. **20% of total cementitious material shall be Fly-Ash**
 - b. Ground Granulated Blast-Furnace Slag: ASTM C 989, Grade 100 or 120.
- C. Normal-Weight Aggregates: ASTM C 33, Class 3S coarse aggregate or better, uniformly graded. Provide aggregates from a single source.
1. Maximum Coarse-Aggregate Size: ASTM C33 Size 57,67 or 7
 2. Fine Aggregate: Free of materials with deleterious reactivity to alkali in cement.
- D. Base Course
1. Base course shall be installed under paving where indicated on the drawings. Unless shown otherwise, base course shall be Class 2 aggregate, as defined in the State of California Specifications (Section 26-1).
- E. Water: Clean, Potable and complying with ASTM C 94.

2.4 ADMIXTURES

- A. No admixtures shall be allowed without written acceptance by the City's Representative. Admixtures that have a negative impact on concrete finish shall not be used. When more than one admixture is used, admixtures shall be compatible. Provide letter from admixture manufacturer that it is appropriate for proposed mix design.
- B. Air-Entraining Admixture: ASTM C 260; "Daravair", "Micro-Air", manufactured by W.R. Grace, Master Builders or equal.

- C. Chemical Admixtures: Admixtures certified by manufacturer to be compatible with other admixtures and that will not contribute to water-soluble chloride ions exceeding those permitted in hardened concrete. Do not use calcium chloride or admixtures containing calcium chloride.
 - 1. Water-Reducing Admixture: ASTM C 494, Type A.
 - 2. Water-Reducing and Retarding Admixture: ASTM C 494, Type D.
 - 3. High-Range, Water-Reducing Admixture: ASTM C 494, Type F.
 - 4. High-Range, Water-Reducing and Retarding Admixture: ASTM C 494, Type G.
- D. Color Additives: ASTM C 979, synthetic mineral-oxide pigments or colored water-reducing admixtures; color stable, free of carbon black, non-fading, and resistant to lime and other alkalis.
 - 1. Manufacturers:
 - a. Davis Colors – website: <https://www.daviscolors.com>, Contact 323-265-8323)
 - b. Or equal approved by City Representative.
 - 2. Color pigments to be added as follows:
 - 1) Concrete Pavement, walls, seatwalls, steps, all curbs and flush bands and exposed concrete—1/2 Lb. lamp black
 - 3. Samples: Prior to constructing the mock-up, provide concrete material color sample panel for approval of each color. Owner reserves the right to change color based on review of sample.

2.5 CURING MATERIALS

- A. Absorptive Cover: AASHTO M 182, Class 2, burlap cloth made from jute or kenaf, weighing approximately 9 oz./sq. yd. when dry.
- B. Moisture-Retaining Cover: ASTM C 171, polyethylene film or white burlap-polyethylene sheet.
- C. Water: Potable.
- D. Clear, Waterborne, Membrane-Forming Curing Compound: ASTM C 309, Type 1, Class B, dissipating.
- E. Clear, Waterborne, Membrane-Forming Curing Compound: ASTM C 1315, Type 1, Class A.

2.6 NONSHRINK GROUT

- A. Non-Shrink Grout: Premixed compound consisting of non-metallic aggregate, cement, water reducing and plasticizing agents; capable of developing minimum compressive strength of 2,400 psi in 48 hours and 7,000 psi in 28 days. SIKAGROUT 212 or approved equal.
- B. Epoxy Grout: Two-part epoxy adhesive product that conforms to the requirements of Simpson SET-XP High Strength Epoxy (ICC-ES-ESR-2508) by Simpson Strong Tie or

equal product with prior written approval of the City’s Representative. Installation shall be in strict conformance with the manufacturer’s recommendations.

- C. Waterstops: self-adhesive bentonite waterstop strip intended to seal cold joints in concrete that conforms to the requirements of Superstop by Tremco Sealants or approved equal.

2.7 SURFACE RETARDER (for exposed aggregate finish)

- A. Surface Retarder: Water based top-surface retarder designed to retard the setting (hydration) of the upper layer of cement paste, producing an exposed-aggregate appearance of the concrete surface. **Product suitable for both horizontal and vertical surfaces**

Acceptable Manufacturers: Dayton Superior Corporation; 1125 Byers Road, Miamisburg, Ohio 45342; Tel: (877) 266-7732; Website: www.DaytonSuperior.com

Product Code	Package Color	Aggregate Size to Expose / Finish
03	Violet	Acid Etch Finish

Product: Dayton Superior "Top Cast" Surface Retarder, of one or more of the following Grade(s), as required to achieve intended aesthetic effect:

2.8 RELATED MATERIALS

- A. Expansion Joint Material: Asphalt-impregnated wood fiber board (with removable polystyrene strip on top edge).
- B. Backer Rod: Butyl rubber (of material that will not react chemically with sealant).
- C. Sealant: Self-leveling non-sagging, puncture-resistant polyurethane sealant, designed for this use. Colors to match adjacent concrete color.
- D. Semi-rigid Joint Fillers: Two-component, semirigid, 100 percent solids, epoxy resin with a Type A shore durometer hardness of 80 per ASTM D 2240.

2.9 CONCRETE MIXTURES

- A. Prepare design mixtures for each type and strength of concrete, proportioned on the basis of laboratory trial mixture or field test data, or both, according to ACI 301.
- B. Cementitious Materials: Use fly ash, pozzolan, ground granulated blast furnace slag, and silica fume as needed to reduce the total amount of portland cement, which would otherwise be used, but not less than 30 percent.
- C. Limit water-soluble, chloride-ion content in hardened concrete to 0.30 percent by weight of cement.
- D. Delivery Tickets: Submit delivery ticket (with copy for Contractor to keep) for each load of concrete delivered to the job, showing at least the following.
 1. Date, Name of ready-mix plant, job location.
 2. Contractor, and full name of Contractor’s representative receiving the concrete.

3. Type, brand, of cement.
4. Class and specified cement contents in bags per cubic yard of concrete.
5. Truck number.
6. Time of loading, time dispatched.
7. Time of arrival, time of unloading.
8. Amount of concrete in load (in cubic yards)
9. Admixtures, if any
10. Maximum aggregate size and amount of aggregate of each size (per cubic yard)
11. Water added at job, if any

2.10 FABRICATING REINFORCEMENT

- A. Fabricate steel reinforcement according to CRSI's "Manual of Standard Practice."

2.11 CONCRETE MIXING

- A. Ready-Mixed Concrete: Measure, batch, mix, and deliver concrete according to ASTM C 94 and furnish batch ticket information.
 1. When air temperature is between 85 and 90 deg F reduce mixing and delivery time from 1-1/2 hours to 75 minutes; when air temperature is above 90 deg F reduce mixing and delivery time to 60 minutes.

3. EXECUTION

3.1 FORMWORK

- A. Ensure formwork conforms to ACI 347R.
- B. Construct forms accurately to dimensions, plumb and true to line and grade.
- C. Use forms that are strong, mortar tight, braced and tied so as to maintain position and shape during placing of reinforcing and concrete.
- D. Set, brace and secure edge forms, bulkheads, and intermediate screed guides to required lines, grades, and elevations.
- E. Install forms to allow continuous progress of work and so form can remain in place at least 24 hours after concrete placement.
- F. Wavy surfaces and bulged walls or slab surfaces resulting from settlement or springing of formwork will be rejected.
- G. Carefully verify and check forms for alignment and level as the Work proceeds.
- H. Make needed adjustments or add additional bracing prior to pouring concrete

3.2 SUBGRADE

- A. Prepare and compact subgrade per the Geotechnical Engineer's report. Obtain approval from City Representative prior to placing base, concrete, etc.

3.3 BASE COURSE

- A. Base course shall be of the depth shown on drawings after compaction.
- B. Compact base to 95% by rolling or other approved method, unless noted otherwise.

3.4 EMBEDDED ITEMS

- A. Place and secure anchorage devices, water lines, access panels, and other embedded items required for adjoining work that is attached to or supported by cast-in-place concrete. Use setting drawings, templates, diagrams, instructions, and directions furnished with items to be embedded.

3.5 STEEL REINFORCEMENT

- A. General: Comply with CRSI's "Manual of Standard Practice" for placing reinforcement.

3.6 JOINTS

- A. General: Construct joints true to line with faces perpendicular to surface plane of concrete.
- B. Construction Joints: Install so strength and appearance of concrete are not impaired, at locations indicated or as approved by the Engineer.
- C. Isolation Joints in Slabs-on-Grade: After removing formwork, install joint-filler strips at slab junctions with vertical surfaces, such as column pedestals, foundation walls, grade beams, and other locations, as indicated.
- D. Contraction Joints: Sawcut score joints in straight lines and in curves as shown on drawings. Joints shall be consistent, cleanly made, and with cleanly cut edges.
- E. Expansion Joints:
 - 1. Shall be set as shown in drawings and between separate pours, straight and true to line, top flush with finish grade, with smooth edges at surface.
 - 2. Repair damaged joints as required and as approved by City Representative.
 - 3. Sealants shall be flush with adjacent surface of paving or wall.
 - a. Sealant shall be smooth, without voids or irregularities.

3.7 CONCRETE PLACEMENT

- A. Before placing concrete, verify that installation of formwork, reinforcement, and embedded items is complete and that required inspections have been performed.
- B. Deposit concrete continuously in one layer or in horizontal layers of such thickness that no new concrete will be placed on concrete that has hardened enough to cause seams or planes of weakness. If a section cannot be placed continuously, provide construction joints as indicated. Deposit concrete to avoid segregation.
 - 1. Consolidate placed concrete with mechanical vibrating equipment according to ACI 301.

- C. Cold-Weather Placement: Comply with ACI 306.1.
- D. Hot-Weather Placement: Comply with ACI 301.

3.8 FINISHING FORMED SURFACES

- A. Rough-Formed Finish (only for footings and concrete that remains unexposed): As-cast concrete texture imparted by form-facing material with tie holes and defects repaired and patched. Remove fins and other projections that exceed specified limits on formed-surface irregularities.
- B. Smooth Rubbed Finish (at Concrete wall with Chalk Art finish): Not later than one day after form removal, moisten concrete surfaces and rub with carborundum brick or another abrasive until producing a uniform color and texture. Do not apply cement grout other than that created by the rubbing process. Repair and patch tie holes and defects. Remove fins and other projections that exceed specified limits on formed-surface irregularities.
- C. Light Broom Finish: The direction of pattern shall be perpendicular to direction of travel on path, or to face of wall, where adjacent to building.
 - 1. Immediately after float finishing, slightly roughen trafficked surface by brooming with fiber-bristle broom perpendicular to main traffic route. Coordinate required final finish with Landscape architect before application.
 - 2. Apply to concrete stair riser and tread.
 - 3. Apply to concrete paving
 - 4. Apply to curbs
- D. Exposed Aggregate Finish: Wash off condition.
 - 1. Apply to Seatwalls and Concrete transfer curb.
 - 2. General: Follow all manufacturer's recommendations and written instructions when applying surface retarder.
 - 3. Application:
 - a. Begin application while surface is still wet, after the evaporation of all bleed water from the surface. Refer to manufacturer instructions on timing of retarder application for wall surfaces.
 - b. Apply surface retarder using low pressure sprayer to produce an even, continuous coating.
 - c. Follow manufacturer's recommended coverage rate; do not under-apply.
 - d. Comply with manufacturer's recommendations regarding rain protection until material is dry.
 - 4. Removal:
 - a. Begin removing retarded cement matrix after dwell time recommended by manufacturer, adjusted for field conditions. Unless field conditions substantially differ from those under which acceptable mockup was produced, begin removal after same time period as was used for mockup.
 - b. Remove cement matrix with garden hose or 25 degree nozzle power washer.
 - c. Stiff bristle broom or mechanical scrubber may be used as the primary or a supplementary means of removal.

- d. Take care not to mechanically remove more material than intended by using overly aggressive methods.

3.9 LINES AND LEVELS

- A. Finish grades on the drawings are shown in feet, to the top of all graded or paved surfaces, walls, curbs, etc. Slope uniformly between elevations shown and make transitions smooth and gradual, unless noted otherwise.
- B. Horizontal curves and radii shall be set tangent to adjacent straight lines or curves, unless noted otherwise. Curves shall be smooth and gradual.
- C. Other than minor field adjustments to meet the intent of the drawings, horizontal layout shall not vary from layout unless approved by City Representative.

3.10 CONCRETE PROTECTING AND CURING

- A. General: Protect freshly placed concrete from premature drying and excessive cold or hot temperatures. Comply with ACI 306.1 for cold-weather protection and ACI 301 for hot-weather protection during curing.
- B. Evaporation Retarder: Apply evaporation retarder to unformed concrete surfaces if hot, dry, or windy conditions cause moisture loss approaching 0.2 lb/sq. ft. x h before and during finishing operations. Apply according to manufacturer's written instructions after placing, screeding, and bull floating or darbying concrete, but before float finishing.
- C. Cure concrete according to ACI 308.1, by one or a combination of the following methods:
 1. Moisture Curing: Keep surfaces continuously moist for not less than seven days.
 2. Moisture-Retaining-Cover Curing: Cover concrete surfaces with moisture-retaining cover for curing concrete, placed in widest practicable width, with sides and ends lapped at least 12 inches, and sealed by waterproof tape or adhesive. Cure for not less than seven days. Immediately repair any holes or tears during curing period using cover material and waterproof tape.
 3. Curing Compound: Apply uniformly in continuous operation by power spray or roller according to manufacturer's written instructions. Recoat areas subjected to heavy rainfall within three hours after initial application. Maintain continuity of coating and repair damage during curing period.

3.11 JOINT FILLING

- A. Prepare, clean, and install joint filler according to manufacturer's written instructions.
 1. Defer joint filling until concrete has aged at least one month. Do not fill joints until construction traffic has permanently ceased.
- B. Remove dirt, debris, saw cuttings, curing compounds, and sealers from joints; leave contact faces of joint clean and dry.
- C. Install semi-rigid joint filler full depth in saw-cut joints and at least 2 inches (50 mm) deep in formed joints. Overfill joint and trim joint filler flush with top of joint after hardening

3.12 CONCRETE SURFACE REPAIRS

- A. Defective Concrete: Repair and patch defective areas when approved by City Representative. Remove and replace concrete that cannot be repaired and patched to City Representative approval.

3.13 FIELD QUALITY CONTROL

- A. Testing and Inspecting: Contractor may engage a qualified independent testing and inspecting agency to perform field tests and inspections and prepare test reports.
 - 1. Testing Services: Tests shall be performed according to ACI 301.

END OF SECTION

SECTION 05 50 00
METAL FABRICATIONS

PART 1 - GENERAL

1.01 SUMMARY

- A. Section Includes: Miscellaneous metal fabrications and related connections including but not limited to the following:
1. Nature Retreat
 2. Vine Arch
 3. Handrails
 4. Signs
 5. Miscellaneous metals

1.02 PRICE AND PAYMENT PROCEDURES

- A. Refer to City of Cupertino Project Manual.

1.03 REFERENCES

- A. The editions referenced herein of Federal Specifications (Fed. Spec.) and of the other standards and specifications published by the following organizations, apply to the work only to the extent specified by the reference. Refer to Section 013000 for information concerning availability and use of references.
1. American National Standards Institute (ANSI)
 2. Aluminum Association (AA)
 3. American Institute of Steel Construction (AISC)
 4. American National Standards Institute (ANSI)
 5. American Society for Testing and Materials (ASTM)
 6. American Welding Society (AWS)
 7. National Association of Architectural Metal Manufacturer's (NAAMM)

1.04 SUBMITTALS

- A. Shop Drawings:
1. Submit shop drawings of metal work noted in 2.01, giving sizes, details of fabrication and construction, methods of assembly and bracing, and locations of hardware, anchors, and accessories.
 2. Contractor shall be responsible for all fabrication and for correct fitting of metal members shown on shop drawings.
- B. Product Data: Submit manufacturer's specifications, anchor details and installation instructions for products used in miscellaneous metal fabrications, including paint products and grout. Color to be selected through submittal process.
- C. Submittal procedures are specified in the City of Cupertino Project Manual.

1.05 REGULATORY REQUIREMENTS:

- A. Provide products meeting the accessibility requirements of the Governing Building Code, Chapter 11B.
- B. Governing codes, regulations and fire and building officials are identified on G0.10 and in the City of Cupertino Project Manual.

1.06 DELIVERY, STORAGE AND HANDLING:

- A. Deliver material in time to insure uninterrupted progress of the work. Store materials in a manner to preclude damage and permit ready access for inspection and identification of each shipment. Store steel materials, either plain or fabricated, above the ground upon platforms, pallets, skids, or other supports. Keep materials free from dirt, grease, and other foreign matter, and protect from corrosion. Material showing evidence of damage will be rejected; immediately remove rejected materials from the work.

1.07 FIELD MEASUREMENTS:

- A. Secure all field measurements required for proper and adequate fabrication and installation of the work. Furnish templates for exact location of items to be embedded in concrete and masonry and setting instructions required for all installation work.

PART 2 - PRODUCTS

2.01 CUSTOM METAL FEATURES

See Drawings and Materials Schedule for Description and Quantity for the below custom items:

- A. Nature Retreat
- B. Vine Arch
- C. Handrails
- D. Grant Recognition Sign
- E. Non-verbal Communication Sign

2.02 MATERIALS:

- A. Aluminum:
 - 1. Extrusions: ASTM B 221-02, alloy and temper specified for each item specified herein.
 - 2. Sheet: ASTM B 209-02a, alloy and temper specified for each item specified herein.
 - 3. Tubing: ASTM B 241-02, 6063-T6 alloy and temper.
- B. Stainless Steel: 316, Brushed finish
- C. Ferrous Metal:
 - 1. Steel, Rolled Shapes, Bars and Plates: Standard structural sections, ASTM A 36-03a.
 - 2. Steel Tubing: ASTM A 500-03 or ASTM A 501-01, grade B, seamless.

3. Steel Pipe: ASTM A 53-02, Type E or S, Grade B, schedule 40, unless otherwise specified.
 4. Steel Sheet:
 - a. Uncoated Sheet: Hot-rolled, ASTM A 1011-03; or cold-rolled ASTM A 1008-03, Class 1; of grade specified for the fabricated item.
 - b. Galvanized Sheet: ASTM A 653-03, Grade SQ, coating designation of G-90 unless otherwise indicated or specified.
 5. Anchors, Bolts, and Fastenings: ASTM A 307-02, Grade A and ASTM A 563-00.
 6. Electrodes: AWS A5.1-91 or A5.5-96 E60XX or E70XX.
 7. Pipe Sleeves: Pipe sleeves through concrete walls and footings shall be standard weight, wrought iron, mild steel, or cast iron sleeves with not less than 1/2 inch space all around between the sleeve and pipe.
- D. Shop Primer:
1. Acceptable Products: Provide one of the following products or equal product approved in accordance with Section 01600:
 - a. Carboline Co.; No. GP-20 or GP-818
 - b. Rust-O-Leum Corp.; No. 678 or 7669
 - c. The Sherwin Williams Co.; No. B50 N 2 or B50N Z 6
 - d. Tnemec Co., Inc.; 10-99 or P10-99
 2. Composition: Fast curing, lead and chromate free, modified alkyd primer.
- E. High-Performance Coating
1. Acceptable Products: Tnemec or approved equal.
 2. Apply per manufacturer instructions.
 3. For use on Nature Retreats and Vine Arch, Handrails and misc. sign posts. Refer to drawings for more information.
- F. Galvanizing Repair Compound:
1. Available Products: Provide one of the following products or equal product complying with the specified requirements:
 - a. Cominco, Ltd.; GalvaGuard
 - b. Keeler & Long; Kolorane Zinc Rich Primer #9700
 - c. ZRC Worldwide; ZRC Cold Galvanizing Compound
 2. Requirements: High zinc dust content galvanizing repair paint or cold or hot applied zinc rich material complying with ASTM A 780-01.
- G. Quick Setting Hydraulic Cement: Provide one of the following products or equal product complying with the specified requirements:
- a. Burke/Edoco Construction Chemicals; Burke Stone
 - b. Dayton Superior Chemical Division; Ankertite Cement
 - c. Lambert Corp.; Super Por-Rok
 - d. Tamms Industries Co.; Rapid Rock
- H. Nonmetallic, Nonshrink Grout
1. Available Products: Provide one of the following products or equal product complying with the specified requirements:
 - a. Burke/Edoco Construction Chemicals: Burke NFNS
 - b. Dayton Superior Chemical Division; Sure-Grip Grout

c. Tamms Industries Co.; Horn Grout

2. Requirements: For grout in exposed to view locations use premixed, nonmetallic, non-corrosive, non-staining grouting compound containing silica sands, portland cement, shrinkage compensating agents and water reducing agents, meeting the requirements of ASTM C 1107-02.

2.03 FABRICATION:

- A. Metal Surfaces: For fabrication of miscellaneous metal work which will be exposed to view, use only materials which are smooth and free of surface blemishes including pitting, seam marks, roller marks, rolled trade names and roughness.
- B. Fabricate and assemble materials in the shop to the greatest extent possible. Perform shearing, flame cutting, and chipping carefully and accurately. Coordinate all connection details to concrete or masonry. Verify all lines, levels, and dimensions, where possible, just before commencing fabrication of connection details. Correct work that does not fit. Schedule and coordinate work under this section with that specified elsewhere in order to produce a workmanlike installation. When not otherwise indicated or specified, comply with applicable requirements of AISC "Specifications for Design, Fabrication and Erection of Structural Steel for Buildings". Finish surfaces of exposed members smooth and free of markings, burrs, or other defects.
- C. Bolt, braze or weld connections as indicated. One-sided or other types of eccentric connections will not be permitted unless indicated, and shown in detail on the shop drawings.
- D. Cut, drill, or punch holes at right angles to the surface of the metal; do not enlarged by burning. Drill holes in base or bearing plates. Provide holes in members to permit connecting the work of other trades.
- E. Galvanizing:
 1. Galvanizing for rolled, pressed and forged steel shapes, plates, bars and strip and for assembled steel products: Zinc coating meeting the requirements of ASTM A 123-02.
 2. Galvanizing for iron and steel hardware: Zinc coating meeting the requirements of ASTM A 153-03.
- F. Shop Painting: Apply shop primer to surfaces of metal fabrications except those which are galvanized or indicated to be embedded in concrete or masonry, unless otherwise indicated.

2.04 MISCELLANEOUS ROLLED STEEL PLATES AND SHAPES:

- A. Support Framing for Mechanical and Electrical and Other Equipment: Fabricate of structural steel angles or other shapes as indicated or required, to support the full weight of the equipment. All connections shall be fully welded together.
- B. Edge and Corner Guards: Fabricate from steel angles and furnish with welded anchors spaced as indicated but not less than 6 feet on centers if not shown.
- C. Shop prime exposed steel surfaces of interior steel items and galvanize exposed steel surfaces of exterior steel items.

PART 3 - EXECUTION

3.01 GENERAL REQUIREMENTS:

- A. Steel and miscellaneous metal work shall conform with the applicable requirements of the referenced "Codes and Standards". Details indicated are typical, similar details apply to similar conditions. Check drawings for dimensions, elevation, size, and locations of installations. Supply miscellaneous metal items in ample time for incorporation in the work. Include reinforcing angles, plates, straps, brackets, hangers, clips, lugs, holes, sleeves, shims, other hardware as indicated or required for erection of steel and miscellaneous metal work and as required to complete the work as indicated.

3.02 WELDED CONNECTIONS:

- A. All welders shall be certified qualified welders. All welders welding light gage metal shall be qualified for light gage metal welding.
- B. Welded connections shall be made in accordance with AWS D1.1-00. All welding shall be done in the shop unless otherwise indicated or specified.
- C. All welds and other connections exposed in the finished work shall be ground and dressed smooth and so that the shape and profile of the item welded is preserved.

3.03 INSTALLATION:

- A. Per manufacturer's recommendation and per direction of the City Representative.

3.04 GALVANIZED FINISH:

- A. Touch up all damaged galvanized finish due to installation, welding, threading or other work with treatment specified herein.

END OF SECTION

SECTION 11 68 00

PLAYGROUND EQUIPMENT

PART 1 - GENERAL

1.1 RELATED DOCUMENTS

- A. Refer to the City of Cupertino Project Manual for general conditions.

1.2 SUMMARY

- A. This Section includes: All labor, materials, equipment, tools, accessories, transportation, and services as required to furnish and install Playground Equipment, including play area age appropriateness markers and playground safety audit.
- B. Related Requirements
 - 1. City of Cupertino Project Manual
 - 2. Section 31 22 00, Grading
 - 3. Section 32 11 00, Base Courses
 - 4. Section 32 13 00, Rigid Paving
 - 5. Section 32 18 16, Playground Protective Surfacing

1.3 DEFINITIONS

- A. Fall Height: According to ASTM F 1487, "the vertical distance between a designated play surface and the protective surfacing beneath it."
- B. HDPE: High-density polyethylene.
- C. IPEMA: International Play Equipment Manufacturers Association.
- D. LLDPE: Linear low-density polyethylene.
- E. MDPE: Medium-density polyethylene.
- F. Use Zone: According to ASTM F 1487, "the area beneath and immediately adjacent to a play structure that is designated for unrestricted circulation around the equipment and on whose surface it is predicted that a user would land when falling from or exiting the equipment." Also called Play Safety Zone.

1.4 REFERENCES

- A. Reference Standards
 - 1. 2022 California Building Code (2022 CBC)
 - 2. Department of Justice 2010 American Disabilities Act Standards for Accessible Design ('2010 ADA').

3. Department of Justice Title II regulation of ADA (28CFR Part 35)
4. Department of Justice Title III regulation of ADA (28 CFR Part 36)
5. U.S. Consumer Product Safety Commission ('CPSC publication #325'): Public Playground Safety Handbook, latest edition.
6. ASTM F1487: Standard Consumer Safety Performance Specification for Playground Equipment for Public Use, latest edition.
7. ASTM F1292, Standard Specification for Impact Attenuation of Surfacing Materials Within the Use Zone of Playground Equipment, latest edition.
8. ASTM F1951: Standard Specification for Determination of Accessibility of Surface Systems Under and Around Playground Equipment, latest edition.
9. ASTM F2223: Standard Guide for ASTM Standards on Playground Surfacing, latest edition.
10. International Play Equipment Manufacturers Association ('IPEMA') Certification Service.

1.5 PERFORMANCE REQUIREMENTS

A. Safety

1. Installation of playground equipment, including any specialty concrete, shall meet the safety requirements of the current CPSC and ASTM F 1487 and Title 22. Social Security; Division 4. Environmental Health; Chapter 22. Safety Regulations for Playgrounds.

1.6 ADMINISTRATIVE REQUIREMENTS

A. Coordination

1. Contractor shall coordinate between playground equipment manufacturer and playground protective surfacing installer.
2. Coordinate construction of equipment use zones and fall heights during installation of playground equipment with installation of protective surfacing specified. Sequence work so playground protective surfacing can be installed immediately after concrete footings, subsurface utilities and piping, flatwork and foundations have set.
3. Contractor shall coordinate with a Certified Playground Safety Inspector as certified by the National Playground Safety Institute and as approved by the City.

B. Pre-Installation Meeting: Convene a meeting one week before starting earthwork for playground equipment to discuss coordination between various installers.

1. Require attendance by personnel responsible for grading and installation of playground equipment, protective surfacing, footings, and adjacent work.
2. Include representatives of Contractor.
3. Notify the the City Representative at least two (2) weeks prior to meeting.

C. Sequencing: Following mobilization and installation of construction fencing to close the existing play area to public use, the Contractor shall perform the following tasks in this order:

1. Removal of play equipment per Section 024100, Demolition.
2. Installation of playground equipment shall occur prior to installation of playground protective surfacing.

3. Documentation of a Safety Audit shall be provided prior to acceptance of playground equipment.
4. The Contractor shall provide documentation of a safety audit of the playground equipment. The safety audit shall be paid for by the Contractor and performed by a third party CPSI. The audit shall be performed prior to any occupancy by the general public. Any corrections necessary shall be paid for by the Contractor and to the satisfaction of the the City Representative.

1.7 SUBMITTALS

- A. Provide submittals in accordance with City of Cupertino Project Manual. Contractor shall provide submittals in a timely manner to facilitate the Owner's ordering of equipment and to allow installation in accordance with the approved construction schedule.
- B. Installer Qualifications
 1. Installer Certificates: Signed by manufacturers certifying that installers comply with requirements.
 2. Provide evidence the installer of the play equipment possesses liability insurance of at least \$1,000,000 from a reputable insurance company covering defects in materials, workmanship, and installation. This liability shall cover any bodily harm resulting from a failure of play equipment due to installation defects.
 3. Qualification Data:
 - a. For Installer: Submit a listing of at least five installations where the brand of play equipment with similar units to those proposed has been installed and has been in successful service for at least five years. This list shall include owner or purchaser; address of installation; service or maintenance organization; date of installation; and contact person and phone number.
 - b. For Manufacturer: Submit documentation that the Playground Equipment Manufacturer is ISO 9001 certified (Quality Management Standard) and ISO 14001 certified (Environmental Management Standard)
- C. Product Data and Installation Instructions: Refer to Deferred Submittal Requirements on G0.00. For each type of product indicated submit two bound copies of play equipment product data, catalog cuts, photo brochures, specifications, and installation procedures, (including diagrams, instructions, scale models) or other printed information in sufficient detail and scope to verify compliance with requirements of the contract documents.
- D. Provide a Certificate of Insurance from the manufacturer, covering both product and general liability, of not less than \$1,000,000. The issuing underwriter shall be AA rated.
- E. Coordination Drawings (see also 32 18 16 Playground Protective Surfacing): Plans, drawn to scale, on which the following items are shown and coordinated with each other, based on input from installers of the items involved:
 1. Critical heights for playground surface or fall heights for equipment.
 2. Extent of surface systems and use zones for equipment.
 3. Depth and type of surface systems and any transitions between depths.
 4. Minimum dimensions from all obstructions, such as curbs and paving, to extent line of fall zones.

- F. Product Certificates: For each type of playground equipment, signed by product manufacturer.
- G. Shop Drawings:
 - 1. Detailed manufacturer information including footings and installation procedures.
- H. Material Samples for Final Color Selection: For each type of material incorporated within the selected play equipment configuration.
- I. Manufacturer Compliance Letter: Play Equipment Manufacturer shall provide Contractor and Owner a letter stating that the equipment design and detailing meets all professional standards of care for playground equipment, including compliance with ASTM, USCPSC Guidelines for Public Playground Safety.
- J. Material Certificates: For the following items, signed by manufacturers:
 - 1. Shop finishes.
 - 2. Recycled plastic.
- K. Submit a statement by the material supplier or equipment manufacturer asserting that the supplied material or equipment meets and is installed according to the specified requirements.
- L. Maintenance Data: For playground equipment and finishes to include in maintenance manuals.
 - 1. Submit two bound copies of procedures and instructions pertaining to frequency of preventive maintenance, inspection, adjustment, lubrication, and cleaning necessary to minimize corrective maintenance and repair for play equipment. A list of all parts and components for the system, by manufacturer's name, part number, and nomenclature, shall be attached.
 - 2. Supply a maintenance kit with each custom play structure that shall include wrenches for tamper-proof hardware, one (1) can of graffiti remover, primer, and spray paint to match the color of the structure, sandpaper, and a comprehensive maintenance manual. The maintenance manual shall include a complete plan drawing of the structure, inspection procedures, inspection report forms, and installation instructions and parts list. The entire kit is to be sent directly to the Owner's representative.
- M. Field quality-control test reports.
- N. Product Test Reports: Based on evaluation of comprehensive tests performed by manufacturer and witnessed by a qualified testing agency, for playground equipment.
- O. Warranty: Special warranty specified in this Spec section, See 1.7.
 - 1. Provide manufacturer's standard warranty against all defects in materials and workmanship for the installed play equipment.
- P. Testing Agency Qualifications: Contractor shall provide an independent agency qualified according to ANSI Z34.1 for testing indicated.
 - 1. Submit IPEMA certification showing compliance with all applicable portions of the current ASTM F-1487 Standard.

1.8 DELIVERY, STORAGE, AND HANDLING

- A. Equipment shall be delivered and stored in accordance with the manufacturer's recommendations.
- B. Protect materials from adverse weather.

1.9 WARRANTY

- A. Special Warranty: Manufacturer's standard form in which manufacturer agrees to repair or replace playground equipment components that fail in materials or workmanship within specified warranty period.
 - 1. Failures include, but are not limited to, the following:
 - a. Structural failures including chipping, breaking or bending.
 - b. Deterioration of metals, metal finishes, and other materials beyond normal weathering.
 - 2. Play Equipment Warranty Period:
 - a. 3 YEAR LIMITED WARRANTY for all moving parts; swing seats and hangers; track ride trolleys and bumpers; spring assemblies for all rocking equipment and any other equipment not included above against failure due to corrosion, deterioration or workmanship.
 - b. 10 YEAR LIMITED WARRANTY for all aluminum; posts, clamps, beam, and caps, against structural failure due to corrosion, deterioration or workmanship. This warranty does not include any cosmetic issues.
 - c. 15 YEAR LIMITED WARRANTY for all plastic and steel components, against structural failure due to corrosion, deterioration or workmanship. This warranty does not include any cosmetic issues.
 - d. 15 YEAR LIMITED WARRANTY for protective plastic coating against structural failure due to corrosion, deterioration or workmanship. This warranty does not include any cosmetic issues.
 - 3. General Warranty:
 - a. Manufactured playground equipment shall be guaranteed against defects in workmanship, materials, or installation for a minimum period of one year after Substantial Completion. Warranty shall include but not be limited to such defects as bubbling, delamination, peeling, loss of integrity, poor ultraviolet stability, lack of permeability, or general deterioration due to weather. All posts shall be guaranteed against deterioration for ten years. All rotationally molded components shall be guaranteed for five years.

1.10 SUBSTITUTIONS

- A. Substitutions were requested to be submitted with bid submittals. Any subsequent substitutions due to lack of availability must meet material quality, color options, play value and spatial requirements of specified products and must be approved by the City representative.

PART 2 - PRODUCTS

2.1 PLAYGROUND EQUIPMENT AND STRUCTURES

For the following Basis-of-Design Products see the Materials Schedule for Model / Description / Qty / Manufacturer / Contact Information:

- A. Embankment Slide: Wide
- B. Embankment Slide: Gemini
- C. Rope Pull
- D. Hand Grips
- E. Spinner
- F. Net Climber
- G. Youth Swings
- H. Nest Swings
- I. Tot Swings
- J. Tot Play Structure

2.2 PLAY AREA AGE APPROPRIATENESS SIGNS

- A. Stickers to be provided on all play equipment products, noting age appropriateness.

2.3 PLAYGROUND SITE INVESTIGATION AND SAFETY AUDIT

- A. The playground site investigation and safety audit (“*audit*”) shall be performed by a Certified Playground Inspector as required by State law for the following types of public playground improvements: construction of new playgrounds, modifications to existing playground equipment and/or the installation of new equipment in an existing playground. The *audit* shall assess the layout and condition of the play equipment and surfacing and *identify any and all* equipment, surfacing and signage that is not in compliance with ASTM F1487-17 and CPSC publication #325. The audit shall include an “impact test” to assess the impact attenuation of play surfacing (see Section 321816). The audit shall be in a written report format, detailed and legible, utilizing checklists as recommended by the National Playground Safety Institute’s Certification Course for Playground Safety Inspectors. The audit shall establish playground equipment and surfacing standard of care.

2.4 MATERIALS

- A. Aluminum: Alloy and temper recommended by manufacturer for type of use and finish indicated.
 - 1. Cast aluminum: ASTM B 179

- B. Steel: Comply with the following:
 - 1. Steel Plates, Shapes, and Bars: ASTM A 36, hot-dip galvanized.
 - 2. Steel Pipe: ASTM A 53 or ASTM A 135, standard-weight, hot-dip galvanized.
 - 3. Steel Tubing: ASTM A 500 or ASTM A 513, cold formed, hot-dip galvanized.
- C. Stainless-Steel Sheet: ASTM A 240 or ASTM A 666; Type 304.
- D. Fittings: ASTM A 467, Class CS, 4/0 or 5/0, commercial-quality, hot-dip galvanized steel connectors and swing or ring hangars.
- E. Castings and Hangers: Malleable iron, ASTM A 47, Grade 32510, hot-dip galvanized.
- F. Hardware: Manufacturer's standard; commercial-quality; corrosion-resistant; hot-dip galvanized steel and iron, stainless steel, or aluminum; of a secure and vandal-resistant design.
- G. Fasteners: Manufacturer's standard; corrosion-resistant; hot-dip galvanized or plated steel and iron, or stainless steel; permanently capped, and theft resistant.
- H. Opaque Plastic: Color impregnated, UV stabilized, and mold resistant.
 - 1. Polyethylene: Fabricated from 96 percent recycled, purified, fractional-melt plastic resin; rotationally molded HDPE, LLDPE, or MDPE with not less than 1/4-inch wall thickness.
- I. Rotationally Molded Poly Parts: These parts shall be molded using prime compounded linear low-density polyethylene with a tensile strength of 2500 psi per ASTM D 638 and with color and UV stabilizing additives. Wall thickness varies by product from .187 inches (3/16 inch) to .312 inches (5/16 inch). Color shall be specified (four standard colors are available).
- J. Permalene Parts: These parts shall be manufactured from .75 inches thick high-density polyethylene that has been specially formulated for optimum UV stability and color retention. Compression-molded products shall meet or exceed density of .933 G/cc per ASTM D 1505, tensile strength of 2400 psi per ASTM D 638. Color shall be specified (standard solid colors are tan, red, blue, green, and yellow). Some permalene parts are available in two-color laminate product with (2) .070 inches thick exterior layers over a .610 inches interior core of contrasting color. Color shall be specified (eight standard two-color options are available).
- K. Custom Components: These parts shall be manufactured in sizes and shapes as shown on the drawings and as required to complete the play equipment layout. Custom components shall meet or exceed ASTM standards as set forth in the General Requirements. All custom components must be approved by the Owner's Representative.
- L. Stepped Play Surfaces: Provide stepped platforms where indicated on Drawings.

PART 3 - EXECUTION

3.1 EXAMINATION

- A. Examine areas and conditions, with Installer present, for compliance with requirements for site clearing, earthwork, site surface and sub-grade drainage, and other conditions affecting performance.
 - 1. Do not begin installation before final grading required for placing protective surfacing is completed, unless otherwise permitted by the Owner's representative.
 - 2. Proceed with installation only after unsatisfactory conditions have been corrected.

3.2 PREPARATION

- A. Prior to start of excavation, Contractor shall lay out the entire outdoor play area and stake location of all elements, including playground equipment, use zones, pathways, planters, and hard surfaces, based on actual playground equipment supplied to be installed. Use zones shall not overlap hard surfaces, and shall meet criteria of current releases of CPSC, ASTM F 1292 and ASTM F 1487. The Owner's representative reserves the right to adjust the equipment locations and other elements to meet field conditions and use zone safety requirements.

3.3 INSTALLATION, GENERAL

- A. General: Comply with manufacturer's written installation instructions, unless more stringent requirements are indicated. Anchor playground equipment securely, positioned at locations and elevations indicated.
 - 1. Maximum Equipment Height: Coordinate installed heights of equipment and components with finished elevations of protective surfacing. Set equipment so fall heights and elevation requirements for age group use and accessibility are within required limits. To meet the impact attenuation requirements of the playground safety surface in accordance with ASTM F1292 and Section 321816 PLAYGROUND PROTECTIVE SURFACES, the maximum accessible height of playground equipment shall be as specified by the manufacturer. Verify that playground equipment elevations comply with requirements for each type and component of equipment.
 - 2. All components of the equipment shall be installed accurately to produce true plumb and level installation.
- B. Post and Footing Installation
 - 1. Excavation: Excavate holes for posts and footings as indicated in firm, undisturbed or compacted sub-grade soil.
 - 2. Post Set on Sub-grade: Level bearing surfaces with drainage fill to required elevation.
 - 3. Post Set with Concrete Footing: Comply with ACI 301 for measuring, batching, mixing, transporting, forming, and placing concrete.
 - a. Set equipment posts in/on concrete footing. Protect portion of posts above footing from concrete splatter. Verify that posts are set plumb or at the correct angle, alignment, height, and spacing.
 - 1) Place concrete around posts and vibrate or tamp for consolidation. Hold posts in position during placement and finishing operations until concrete is sufficiently cured.

- b. Embedded Items: Use setting drawings and manufacturer's written instructions to ensure correct installation of anchorages for equipment.
- c. Concrete Footings: Smooth top, and shape to shed water.

3.4 PLAY AREA LAYOUT REVISIONS

- A. The play area equipment layout, as shown on the Drawings, is based on the use of specific equipment designed for specific aesthetic character, play value and activities. The use of other equipment suppliers with different configurations, if approved, will require the Contractor to provide a revised play equipment layout and obtain approval of both the equipment and the play area layout from the Owner's Representative. Contractor shall be responsible for all costs to revise the layout including review of the layout and documentation of the revised layout by Owner's consultant. The revised play equipment layout shall include appropriate safety use zone clearances for the equipment selected.

3.5 LEVEL OF SAFETY SURFACING

- A. All play equipment located in areas of sand, wood fiber, or other loose fill surfacing shall be clearly marked to indicate the finished level of safety surfacing material to meet impact-attenuating requirements. All metal posts, springs or supports shall be as marked by the manufacturer. Those items not marked by the manufacturer shall be marked with a 3/4" circle painted with black epoxy paint.

3.6 QUALITY CONTROL, INSPECTION AND ACCEPTANCE

- A. Arrange for playground equipment manufacturer's technical personnel to inspect playground and playground equipment and components during installation and at final completion and to certify compliance with the following:
 - 1. ASTM F 1487.
 - 2. CPSC No. 325.
- B. Notify the Owner's representative at least 48 hours in advance of date and time of final inspection.
- C. Replace all defective or damaged play equipment prior to acceptance.
- D. Prior to final inspection and acceptance, remove all rubbish and excess material for disposal as approved, and leave area in a neat, satisfactory condition.

E. CERTIFICATION INSPECTION

- 1. All play equipment shall be inspected by a Playground Safety Inspector with a valid certification from the National Playground Safety Institute (NPSI) for compliance in accordance with ASTM F 1487-98 and the USCPSC Handbook for Public Playground Safety. Contractor to provide a signed documentation of compliance certification. Potential inspectors include, but are not limited to:

- a. Community Playgrounds, 200 Commercial Street, Vallejo, CA
415-892-8100
- b. Timothy R. Kelly, CPSI; TRK Playground Safety, LLC
trkplay@gmail.com; 559.642.4939 (office); 559.760.4024 (cell)
46853 Chukchansi Road, Coarsegold, CA 93614

END OF SECTION

SECTION 12 93 00

SITE FURNISHINGS

PART 1 - GENERAL

1.1 RELATED DOCUMENTS

- A. Refer to the City of Cupertino Project. Manual.

1.2 SUMMARY

- A. Related Sections: see electrical plans/specifications for restroom lighting fixtures.
- B. This Section includes the following site furnishing types to be provided and installed by the contractor. See Products and Materials Schedule for specific information.
 - 1. Tables and Chairs
 - 2. Benches & Seating Elements
 - 3. Shade Sails
 - 4. Trash Receptacles
 - 5. Bike Racks
 - 6. Music Elements
 - 7. Raised Sand Table
 - 8. Interactive Art Feature and 3Form Color Inserts

1.3 SUBMITTALS

- A. Product Data: For each type of product indicated.
- B. Samples for Initial Selection: For units with factory-applied color finishes, provide samples of colors indicated for Landscape Architect's approval.
 - 1. Provide additional samples as needed for Landscape Architect's approval.
 - 2. Do not order and deliver product to job site until submittal has been approved.
- C. Samples for Verification: For each type of exposed finish required, prepared on Samples of size indicated below.
 - 1. Size: Not less than 6-inch-long linear components and 4-inch square sheet components.
- D. Product Schedule: For site furnishings. Use same designations indicated on Drawings.
- E. Material Certificates: For site furnishings, signed by manufacturers.
 - 1. Wood Preservative Treatment: Include certification by treating plant stating type of preservative solution and pressure process used, net amount of preservative retained, and compliance with applicable standards.

2. Sustainably Harvested Wood: Include certification by manufacturer and from sources that participate in sustained yield programs.

F. Maintenance Data.

G. Shop Drawings: Show fabrication and installation details for custom fabricated elements.

H. Provide model and/or detail drawings for all fabricated elements.

1.4 PROJECT CONDITIONS

A. Field Measurements: Verify actual locations of slabs, walls, and other construction contiguous with site furnishings and sculptural elements by field measurements before fabrication and indicate measurements on Shop Drawings.

1. Established Dimensions: Where field measurements cannot be made without delaying the Work, establish dimensions and proceed with fabricating elements without field measurements. Coordinate wall and other contiguous construction to ensure that actual dimensions correspond to established dimensions.
2. Provide allowance for minor adjustment and fitting at site.

1.5 COORDINATION

A. Coordinate installation of anchorages for site furnishings. Furnish setting drawings, templates, and directions for installing anchorages, including sleeves, concrete inserts, anchor bolts, and items with integral anchors, that are to be embedded in concrete or masonry. Deliver such items to Project site in time for installation.

PART 2 - PRODUCTS

2.1 MATERIALS

A. Aluminum: Alloy and temper recommended by aluminum producer and finisher for type of use and finish indicated; free of surface blemishes and complying with the following:

1. Rolled or Cold-Finished Bars, Rods, and Wire: ASTM B 211 (ASTM B 211M).
2. Extruded Bars, Rods, Wire, Profiles, and Tubes: ASTM B 221 (ASTM B 221M).
3. Structural Pipe and Tube: ASTM B 429.
4. Sheet and Plate: ASTM B 209 (ASTM B 209M).
5. Castings: ASTM B 26/B 26M.

B. Steel and Iron: Free of surface blemishes and complying with the following:

1. Plates, Shapes, and Bars: ASTM A 36/A 36M.
2. Steel Pipe: Standard-weight steel pipe complying with ASTM A 53, or electric-resistance-welded pipe complying with ASTM A 135.
3. Tubing: Cold-formed steel tubing complying with ASTM A 500.

4. Mechanical Tubing: Cold-rolled, electric-resistance-welded carbon or alloy steel tubing complying with ASTM A 513, or steel tubing fabricated from steel complying with ASTM A 1011/A 1011M and complying with dimensional tolerances in ASTM A 500; zinc coated internally and externally.
 5. Sheet: Commercial steel sheet complying with ASTM A 1011/A 1011M.
 6. Perforated Metal: From steel sheet not less than 0.1196-inch (3.0-mm)]nominal thickness; manufacturer's standard perforation pattern.
 7. Expanded Metal: Carbon-steel sheets, deburred after expansion, and complying with ASTM F 1267.
 8. Malleable-Iron Castings: ASTM A 47/A 47M, grade as recommended by fabricator for type of use intended.
 9. Gray-Iron Castings: ASTM A 48/A 48M, Class 200.
- C. Stainless Steel: Free of surface blemishes and complying with the following:
1. Sheet, Strip, Plate, and Flat Bars: ASTM A 666.
 2. Pipe: Schedule 40 steel pipe complying with ASTM A 312/A 312M.
 3. Tubing: ASTM A 554.
- D. Anchors, Fasteners, Fittings, and Hardware: Manufacturer's standard, corrosion-resistant-coated or noncorrodible materials commercial quality tamperproof, vandal and theft resistant, concealed, recessed, and capped or plugged.
1. Angle Anchors: For inconspicuously bolting legs of site furnishings to on grade substrate; extent as indicated.
 2. Antitheft Hold-Down Brackets: For securing site furnishings to substrate;] [extent as indicated on Drawings.
- E. Nonshrink, Nonmetallic Grout: Premixed, factory-packaged, nonstaining, noncorrosive, nongaseous grout complying with ASTM C 1107; recommended in writing by manufacturer, for exterior applications.
- F. Erosion-Resistant Anchoring Cement: Factory-packaged, nonshrink, nonstaining, hydraulic-controlled expansion cement formulation for mixing with potable water at Project site to create pourable anchoring, patching, and grouting compound; resistant to erosion from water exposure without needing protection by a sealer or waterproof coating; recommended in writing by manufacturer, for exterior applications.
- G. Galvanizing: Where indicated for steel and iron components, provide the following protective zinc coating applied to components after fabrication:
1. Zinc-Coated Tubing: External, zinc with organic overcoat, consisting of a minimum of 0.9 oz./sq. ft. (0.27 kg/sq. m) of zinc after welding, a chromate conversion coating, and a clear, polymer film. Internal, same as external or consisting of 81 percent zinc pigmented coating, not less than 0.3 mil (0.0076 mm) thick.
 2. Hot-Dip Galvanizing: According to ASTM A 123/A 123M, ASTM A 153/A 153M, or ASTM A 924/A 924M

2.2 SITE FURNISHINGS

For the following Basis-of-Design Products see the Materials Schedule for primary information on Model / Description/ Qty / Manufacturer / Email Contact and Drawings for additional information.

- A. Game Table & Chairs
- B. Game Table & Chairs-ADA version
- C. Picnic Table
- D. Picnic Table – ADA version
- E. Buffet Table
- F. Park Bench
- G. Glider Bench
- H. Shade Sails and Posts at Slide Hill
- I. Bike Rack
- J. Trash Receptacle
 - 1. This product is OFCI. Contractor to assemble as needed, install concrete pad for surface mounting and attach per manufacturer’s instructions.
- K. Chimes
- L. Drums
- M. Log Seating Edge
 - 1. Wood species: Redwood, Alaska Yellow Cedar or long-lasting and durable approved equal.
- N. Plop Seats/Bench
- O. Raised Sand Table
 - 1. Basis of Design product: Precast concrete sand table (Cust. No. 011207/Jollyman Inclusive Playground Sand Table), fabricated by QCP or approved equal. Contact: Neil Elenzweig, neil.elenzweig@qcp-corp.com, (951) 737-6240.
 - 2. Product to include:
 - a. Two symmetrical halves with notches for contractor lowering into place with a forklift.
 - b. Attachments to secure to footing
 - c. Weep holes in basin, with rubber fitting and screen.
 - d. Low carbon concrete
 - 3. Contractor to purchase, ship, prepare footing per Drawings and install.
- P. Interactive Art Feature & 3Form Color Inserts
 - 1. Interactive Art Feature (also called kaleidoscope in design) and 3Form color inserts with frame for chalk wall to be fabricated by UAP. Contacts: Jason Marquis at Jason.marquis@uapcompany.com, 1-917-757-9913 and Tyler Smith at

tyler.smith@uapcompany.com, 1-917-581-0771, see sections 2.5 and 3.2 for contractor's responsibilities.

2.3 CONDITION

- A. All products are to be new and in first class condition.

2.4 WARRANTY

- A. **Manufacturer's Warranty:** Contractor shall arrange manufacturer's warranty to the effect that all manufactured products shall carry a minimum one-year manufacturer's warranty, which shall be transferred to the owner at time of acceptance. The warranty period shall commence the date of installation. Early delivery shall not limit the installed warranty period.
- B. **Contractors Warranty:** Contractor shall warrant all workmanship in addition to the manufacturer's warranty for a period of one year from the date of acceptance.

2.5 FABRICATION

- A. **Metal Components:** Form to required shapes and sizes with true, consistent curves, lines, and angles. Separate metals from dissimilar materials to prevent electrolytic action.
- B. **Welded Connections:** At exposed connections, finish surfaces smooth and blended so no roughness or unevenness shows after finishing and welded surface matches contours of adjoining surfaces.
- C. **Pipes and Tubes:** Form simple and compound curves by bending members in jigs to produce uniform curvature for each repetitive configuration required; maintain cylindrical cross section of member throughout entire bend without buckling, twisting, cracking, or otherwise deforming exposed surfaces of handrail and railing components.
- D. **Preservative-Treated Wood Components:** Complete fabrication of treated items before treatment if possible. If cut after treatment, apply field treatment complying with AWPA M4 to cut surfaces.
- E. **Exposed Surfaces:** Polished, sanded, or otherwise finished; all surfaces smooth, free of burrs, barbs, splinters, and sharpness; all edges and ends rolled, rounded, or capped.
- F. **Factory Assembly:** Assemble components in the factory to greatest extent possible to minimize field assembly. Clearly mark units for assembly in the field.
- G. **Fabrication - Interactive Art Feature & 3Form Color Inserts:**
Custom kaleidoscope sculpture to be fabricated by UAP. Vertical stainless steel tower with four large rotating pairs of transparent cast resin 'leaves' and three accessible handles to control rotation. Ground to top leaf height is 14.25 feet. All components are steel or stainless steel with the exception of bearings which are outdoor-rated plastic; leaves to be 3Form Koda Xt resin, sandstone finish, colors to be Citron (G26), Capri (G53), Prince (V12), and Calypso (B23). Base of tower is a 10-inch diameter stainless

steel tube that is 40-inches high; remainder of vertical tower is schedule 40 size 6 stainless steel pipe. The base of the tower is to be welded to a 19 7/16" diameter, 1/2" thick stainless steel base plate. The base plate will be anchored via hilti glue in anchors to a footing as shown in the project's structural dwgs. The base plate, tower and all associated kinetic elements are to be supplied by the Fabricator and shipped to site for receipt by Contractor. Contractor to procure and coordinate fabrication and shipping directly with Fabricator. The sculpture will be packed with the 14.25' tower assembled, but with the cover panels and leaves packed loose, and will include necessary hardware for the installation of covers and leaves. Contractor will be responsible for but not limited to procurement of sculpture, communication/coordination of fabrication and shipping, site preparation, pouring the foundation, supply of foundation anchors, and installation of the sculpture per installation drawings supplied by the fabricator. The installation process will consist of:

- Layout and anchoring of post to foundation via base plate
- Attachment of (6) cover plates at lower portion of base
- Attachment of (3) operating handles
- Attachment of (8) leaf assemblies to (4) collars at top of tower

The General Contractor will be responsible for final paving above baseplate.UAP to also supply 3Form color inserts and ship with interactive art feature for Contractor to use for Conc. Wall with Chalk Art Finish construction. Contractor to supply shop drawings for attaching 3Form color inserts into wall.

2.6 FINISHES, GENERAL

- A. Comply with NAAMM's "Metal Finishes Manual for Architectural and Metal Products" for recommendations for applying and designating finishes.
- B. Appearance of Finished Work: Variations in appearance of abutting or adjacent pieces are acceptable if they are within one-half of the range of approved Samples. Noticeable variations in the same piece are not acceptable. Variations in appearance of other components are acceptable if they are within the range of approved Samples and are assembled or installed to minimize contrast.

2.7 ALUMINUM FINISHES

- A. Baked-Enamel, Powder-Coat Finish: Manufacturer's standard, baked, polyester, powder-coat finish complying with finish manufacturer's written instructions for surface preparation, including pretreatment, application, baking, and minimum dry film thickness.

2.8 STEEL AND GALVANIZED STEEL FINISHES

- A. Baked-Enamel, Powder-Coat Finish: Manufacturer's standard, baked, polyester, powder-coat finish complying with finish manufacturer's written instructions for surface preparation, including pretreatment, application, baking, and minimum dry film thickness.

- B. PVC Finish: Manufacturer's standard, UV-light stabilized, mold-resistant, slip-resistant, matte-textured, dipped or sprayed-on, PVC-plastisol finish, with flame retardant added; complying with coating manufacturer's written instructions for pretreatment, application, and minimum dry film thickness.

2.9 IRON FINISHES

- A. Baked-Enamel, Powder-Coat Finish: Manufacturer's standard, baked, polyester, powder-coat finish complying with finish manufacturer's written instructions for surface preparation, including pretreatment, application, baking, and minimum dry film thickness.

2.10 STAINLESS-STEEL FINISHES

- A. Remove tool and die marks and stretch lines or blend into finish.
- B. Grind and polish surfaces to produce uniform, directionally textured, polished finish indicated, free of cross scratches. Run grain with long dimension of each piece.

PART 3 - EXECUTION

3.1 EXAMINATION

- A. Examine areas and conditions, with Installer present, for compliance with requirements for correct and level finished grade, mounting surfaces, installation tolerances, and other conditions affecting performance.
 - 1. Proceed with installation only after unsatisfactory conditions have been corrected.

3.2 INSTALLATION, GENERAL

- A. Comply with manufacturer's written installation instructions unless more stringent requirements are indicated. Complete field assembly of site furnishings where required.
- B. Install site furnishings level, plumb, true, and securely anchored at locations indicated on Drawings.
- C. Post Setting: Set cast-in support posts in concrete footing plumb or at correct angle and aligned and at correct height and spacing.
- D. Posts Set into Voids in Concrete: Form or core-drill holes for installing posts in concrete to depth recommended in writing by manufacturer of site furnishings and fill annular space between post and concrete with non-shrink, nonmetallic grout, mixed and placed to comply with anchoring material manufacturer's written instructions.
- E. Pipe Sleeves: Use steel pipe sleeves preset and anchored into concrete for installing posts. After posts have been inserted into sleeves, fill annular space between post and sleeve with non-shrink, nonmetallic grout, mixed and placed to comply with anchoring material manufacturer's written instructions.

- F. Raised Sand Table: Install per fabricator's instructions
- G. Interactive Art Feature: Install per fabricator's written instructions
- H. 3Form Color Insert: Submit shop drawings. Install securely anchored, preventing toe- or finger-holds.

3.3 CLEANING

- A. After completing site furnishing installation, inspect components. Remove spots, dirt, and debris. Repair damaged finishes to match original finish or replace component.

END OF SECTION

SECTION 13000
PREFABRICATED RESTROOM OR RESTROOM/CONCESSION BUILDING

A. General, Specifications and Clarification of Prefabricated Building and Site Installation

1. This portion of the bid specifications does not follow the CSI standard format as the prefabricated structure in this bid is an **offsite constructed “product”** and not “typical” general construction.
2. The **installation of the product on site is general construction**, which must be coordinated between the general contractor and the subcontractor. Specifications for the building foundation/pad shall be provided herein by the specified design/build subcontractor. Due to the responsibility of the specified building subcontractor for architecture, engineering and a five-year warranty, the site pad/foundation must meet the subcontractor’s design so the pad and building can be considered from a single source for warranty purposes. The subcontractor must accept the pad and compactions tests before they take responsibility for the entire system under their warranty.

B. Architectural Design/Engineering and Insurance Responsibility

1. While the City of Cupertino has provided bid specifications and a design for the building, the building design/build subcontractor remains legally responsible for architecture, engineering, and all applicable building, safety, health, fire, and accessibility code compliance. Since they hold professional design responsibility to the owner, the building subcontractor must furnish certification that they provide product liability insurance in the amounts required by the general specifications **to cover property damage and personal injury**. Final drawings shall be stamped by an California engineer and California Department of Housing and Community Development, suitable for local permitting.

C. Errors and Omissions Insurance

1. The building design/build subcontractor must also provide an additional Professional Architectural and Engineering Errors and Omissions insurance, in the minimum amount of \$2,000,000, **to cover claims against the owner or the general contractor for State and Federal ADA handicapped accessibility and other design/engineering code issues**. This Errors and Omission Policy must remain in effect for 5 years from the completion and owner acceptance of the project. Product liability insurance (since it does not cover professional design responsibility only) will be insufficient for this bid and will be cause for rejection of the bidder.

D. Insurance for the Building offsite, while in transit, and/or on site until turn over and final owner acceptance.

1. The subcontractor may request invoicing for a percentage of building completion in-plant, monthly. Under UCC law, this means that the subcontractor is turning over

responsibility for the portion invoiced to the owner, yet the building will not be on the owner's property and may not be covered by the owner's insurance. Therefore, the building subcontractor must provide a separate insurance policy insuring the owner and general contractor as additionally insured for liability, damage and/or vandalism to the building while in the manufacturing facility, while in transit, and/or while in storage at a certified bonded storage facility or at the final project site for up to \$200,000 for each prefabricated building module, until the building is final accepted by owner.

E. General Contractor Coordination with Design/Build Subcontractor

1. The specified prefabricated public restroom building requires coordination between the General Contractor (who prepares the site subgrade and delivery access for the prefabricated building) and the prefabricated restroom building subcontractor (who completes the architectural design, engineering, off-site building construction, delivery and installation on site.) The specified prefabricated restroom building specifications include unique components/systems which are custom to the restroom building subcontractor. Since the restroom subcontractor is responsible for design, additional insurance requirements for errors and omissions are required.

F. General Contractor, General Scope of Work

1. The general contractor for this project is responsible for the site survey and staking the building locations, finished slab survey elevations and marking on site, construction and compaction of the required building pads; access to the site for a large crane and tractor trailers delivering the prefabricated building; providing water, sewer, and power at a point of connection (POC) within 6 feet of the building and at the depth required by the building subcontractor and local code; and the installation of any sidewalks outside the building footprint.
2. The general contractor is responsible for verification to the building subcontractor design/build firm that there are no unanticipated site delivery issues such as overhead wires, trees, tree roots, or existing grade changes and that prevent a clear path of travel between a roadway and the final site exists for a tractor trailer and crane to expedite delivery. The design/build subcontractor requires that the general contractor certify that the required delivery crane must be able to set the building modules within 35' distance from the center of the building to the center of the crane hoist.

G. Prefabricated Restroom Building, General Scope of Work:

1. The prefabricated restroom building specialist will provide to the general contractor final building design architectural drawings and engineering calculations under the responsibility of a licensed structural engineer, in compliance with all local, state and federal codes. The design/build subcontractor shall construct the building offsite as a permanently relocatable building, transport it to the final required destination, and install the building turnkey, on a general contractor prepared pad per the drawings included in this bid.

H. Licensing:

The subcontractor must comply with all the State of California; Department of Housing and Community Development, prefabricated “Commercial Modular Requirements” as follows:

1. The building *manufacturer* must be licensed by the State of California, Department of Housing and Community Development as a manufacturer.
2. The selling dealer (if applicable) must be an California licensed dealer and present their license for verification with the bid.
3. The licensed dealer must also possess a State of California Contractors License Board Class B License and present their license for verification with the bid.

I. Bid Standard for the Prefabricated Restroom Building

1. The City of Cupertino understands that there are several firms who design and build various types of public restroom building in varying quality and architectural styles, using similar or different construction methods and materials. For the purpose of this bid, the owner has selected:

Public Restroom Company, 2587 Business Parkway, Minden, NV 89423 and specifies herein that this firm is the standard for architectural design (safety, green design, code compliance, and site-specific compatibility.) PRC is also the standard of building performance and quality for the 50-year building design-life with low-maintenance based upon the longevity of the materials selected. Other firms quoting “or equal” whose criteria and standards do not comply will be rejected.

Contact: Steven Myler, Regional Sales Manager
Phone: 888-888-2060 ext. 103
Fax: 888-888-1448
Email: steve@publicrestroomcompany.com
Web: www.publicrestroomcompany.com

2. Pre-cast structures are not acceptable.

J. “Or Equal Restroom Design/Build Subcontractors”

The City of Cupertino may also allow other firms to become qualified to bid, but any firms so authorized to bid must fully comply with these bid specifications and plans or be subject to post bid rejection.

- a) Or Equal applicant shall provide scaled floor plans and elevations, to show general architectural design criteria is met.
- b) Or Equal applicant shall provide a written list of each deviation from the published bid specifications/plans. Lack of specificity to each deviation from the bid specifications will be cause for rejection.
- c) Or Equal applicant shall provide a manufacturer’s certification of concrete test

-
- compliance from a national independent testing laboratory. The written report must state the concrete compressive strength and absorption resistance per ASTM standard #C39 and #C642, respectively.
- d) Or Equal applicant must provide a list of every building they designed and built over the last 3 years utilizing the same building materials/systems design criteria as published in this bid. Provide date of building bid, date of completion, and most knowledgeable owner contact.
 - e) Or equal applicant shall provide certification of the special insurance required in this bid.
 - f) Or Equal applicant shall be responsible for and bear all cost for architecture, plan checks, design and structural engineering and all fees in obtaining approvals and permits from applicable agencies.
3. The City of Cupertino or their consultant will be solely responsible for the decision to accept or reject the “or equal” submission.

J. Certificate of Off-site Inspection and Construction Compliance, Provision for Maintenance Manuals, and Warranty

1. The off-site restroom construction requires that a licensed third-party inspection firm provide the owner and the local building official with certification and compliance for the building with the approved plans and specifications. A certificate of compliance shall be issued by this inspector to the local building official to provide certification that the building meet and or exceed the approved plans and applicable codes.
2. At the project conclusion, the building subcontractor shall furnish two sets of complete maintenance manuals including a trouble shooting guide, location of manufacturers of key components for replacement parts together with final as-built plans, and a **5-year component/20-year structural warranty** to the owner or general contractor.

K. Site Scope of Work by General Contractor

The general contractor shall prepare the restroom building subgrade to receive the prefabricated building in accordance with the bid subgrade preparation drawings or foundation plan.

1. The building subgrade/footings shall be constructed per the bid drawings.
2. The General Contractor shall provide water point of service at 30” below finished building slabs; sewer at 24” below the finished building slabs; and electrical at 36” below the finished building slabs or other per bid plans.
3. General Contractor shall coordinate with restroom subcontractor to provide full site delivery access for a 70’ tractor-trailer and hydro crane to the final building sites.
4. If the final site access is over existing sidewalks, utilities, or landscaping, the General Contractor shall be responsible for plating and or tree trimming, utility line removal, or other to protect any existing conditions.
5. The hydro crane must be able to locate no greater than 35’ from the center point of the building to the center point of the crane.

-
6. The utilities shall be furnished per bid site plans at specified points of connection (POC) nominally 6' from the building lines.
 7. General contractor shall furnish and install final grading, landscaping and sidewalks.

M. Connection to Utilities

1. The restroom subcontractor will stub-out: Electrical, Water, and Sewer at the proper POINT OF CONNECTION AND AT THE PROPER ELEVATION BELOW GRADE, for this project. Restroom subcontractor shall provide final hook up of the water from building to POC; sewer hookup to POC; and electrical sleeve from building panel to POC only. Final utility connections shall be by General Contractor or others. General contractor shall flush the water lines thoroughly before making final water connection to the building. **Thoroughly flushing the water lines for AT LEAST 30 MINUTES is critical to ensure that the new code required low-flow fixtures and flush valves that are extremely sensitive to particulate matter in the water will not malfunction.**

N. Concrete Slab, Required Independent Testing Laboratory Certification:

1. The prefabricated building slabs special concrete technology claims to be water and urine resistant for life due to special additive technology. The building subcontractor must furnish a test certification of compliance from a national independent testing laboratory to support the claim for absorption resistance. The written report must state the concrete compressive strength (minimum of 7,000 PSI) and absorption resistance (not greater than 3%) per ASTM standard #C642 and #C39 respectively. Since this non-absorbency capability is so significant, the design/build subcontractor must provide a general certification of compliance.

O. Prefabricated Restroom Building:

1. The City of Cupertino has evaluated several prefabricated restroom building suppliers. This bid requires such building be used in lieu of site-built traditional construction because of the unique built-in advantages guaranteed by the design/build firm. This technology includes many new innovations such as non-absorbent concrete; anti-microbial components to reduce health risks; built in vandal resistance design; lowered maintenance and long-term warranties that reduce owner risk for failure. The specifications below are written around this new technology.

P. Mat Engineered Concrete Building Slab/Foundation:

1. The mat engineered 8" thick slab/foundation shall be engineered and constructed to withstand the transportation weight of the building without cracking and to resist absorption from any liquids deposited on the surface. The concrete slab shall be constructed inside a steel angle curb, reinforced with dual mats (tension and compression,) and poured with a custom concrete formula with special admixtures to create a finished slab that is waterproof for life.
2. The building slab/foundation will include the area under the covered entry.
3. Perimeter Steel Curb: 5/16" 50,000 kip steel 6" X 6" welded continuous angle.

-
4. Rebar Steel Mat: Two layers of 40,000 tensile steel rebar in varying sizes per engineers' requirements, including a perimeter structural continuous grade beam design inside the exterior steel angle and at any other location deemed by the engineer of record as required for the use intended. In coastal locations or when required for corrosion resistance rebar shall be epoxy coated or fiberglass to resist permanent corrosion. Rebar mats shall be wire tied to code with a minimum of three turns of the wire and overlaps shall be minimum of 15 diameters for any connection.
 5. All slab openings shall be surrounded with two layers of steel collars as required by the engineer of record to stop corner cracking and to reinforce the openings for lifting.
 6. 1" thick by 3" minimum length threaded nuts shall be welded to the steel perimeter frame with continuous ¼" fillet welds. Nuts shall be welded to common steel plates per the engineer of records design and attached to the interior steel rebar structural mats.
 7. The engineer of record shall provide lifting locations with sufficient reinforcement to allow the safe lifting of the entire designed weight of the structure with dual 1" steel bolts and washers at each lifting location. The number of lifting locations with each location fitted with removable ¾" 8" X 8" 50,000 tensile strength steel angles shall be determined by the engineer of record.
 8. The slab shall be poured over a 1" thick steel plate table. The concrete mix design shall not exceed a 3" slump and shall be stinger vibrated for maximum consolidation. All floors shall slope to any floor drains within each room and if no floor drain is present the floor should not slope. The surface shall be a very light broom that should meet a coefficient of friction on the surface of .06. Birdbaths shall be cause for rejection.
 9. The steel perimeter angle will remain below the concrete surface by nominal two inches to prevent corrosion. After the site concrete sidewalks are poured, the joint shall be full flow sealed with self-leveling grey urethane caulk to prevent penetration of water into the joint.
 10. The building shall be designed for future relocation and shall provide protection for the lifting openings in the mat slab so that the threaded openings will be available for future use if needed.
 11. The building system shall be designed for placement on a general contractor site prepared class 2 building subgrade/and or footings as required by code, per the bid drawings, suitable for 1500 pounds soil bearing capacity minimum. Any soils survey (if necessary) shall be by owner or engineer of record.

Q. Exterior & Interior Masonry Block Walls

1. The block walls shall be nominal 8" x 16" CMU. The building corners shall have special corner return block for structural integrity. All CMU shall be custom fabricated with an enlarged interior hole for placement of the grout and vertical rebar. The block walls shall be nominal 8" x 16" CMU. The building corners shall have special corner return block that matches the exterior finish and creates a uniform appearance. All CMU shall be custom fabricated with an enlarged interior hole for placement of the grout and vertical rebar. The exterior walls shall be 4"

thickness per State of California codes or engineering for wind and seismic. The interior walls shall be 4" block to nominally 7'-4" above finished floor and wood-framed with applicable required finishes above for pony and gable walls. A structural steel tubular .188 wall cap beam shall be welded to 5/16" 40,000 kip steel plate embeds, at intervals per the engineer of record, within the masonry wall. Cap beam shall be ZRC primed and painted, color to be selected by owner.

2. The 8" mat engineered concrete slab shall be cured a minimum of 7 days. Holes for vertical dowels shall be drilled into the mat engineered slab avoiding any grade beams or other structural reinforcement. Once the holes are drilled, blow out the remaining material and using two-part structural epoxy, wet set the #3 or #4 vertical rebar (as specified on the engineering calculations into holes drilled to the depth per the engineer of record requirements. Each rebar shall be held vertical to allow equal epoxy support to each dowel during the drying period. Engineering calculations require that rebar shall be installed in each concrete block center void or every block hole. The engineered uplift on each rebar shall be sufficient to restrain any load imposed on the masonry block wall for vertical rebar pull out from the concrete mat engineered slab.

R. Roof System

1. The **Gable** roof structure shall be 2" x 6" wood rafters at 24" on center with 5/8" OSB sheathing and ice and water shield membrane with **26 gauge** standing seam metal roof, color to be selected by owner from manufacturer's brochure. Building roof rake and fascia shall be wrapped with 16 gauge formed metal, primed and painted. Color to be selected by owner.
2. The roof design shall exceed compliance with local code at 20 PSF live load and wind load "C".
3. The room ventilation screens (described in a following section) shall be attached to the gable truss frames and vandal resistant. Roof color shall be determined by owner and selected from the color chart by restroom supplier.

S. Interior Wall Finish:

1. Interior precision CMU block masonry walls shall be smoothed to a pebble grain finish with 2-4 mil layers of 7-day curing block fillers and painted with two additional 4 mil layers of industrial high solids (white) industrial grade enamel. Walls shall be painted white with industrial high solids enamel. Utility chase and storage area shall be natural block finish.

T. Exterior Wall Finish, Masonry and Gable

1. The building exterior finish shall be **smooth precision block covered by an applied Stucco finish** 8" x 16" CMU to wall height per the exterior elevations in the bid plans. The block shall be covered with 2-4 mil layers of 7-day curing block fillers and painted with two additional 4 mil layers of industrial high solids industrial grade enamel, color selected by Owner. The gable area finish shall be **applied Stucco finish and** painted in a color selected by owner.

U. Passive Ventilation System (Restrooms)

-
1. Shall be Struded Aluminum Model # D-DBE-04 to fit Rough Opening, set in welded stainless steel angles attached to the masonry wall with vandal resistant stainless steel screws, per plans. There shall also be a 8" x 16" aluminum louvered vent in each restroom located on the chase at 9' AFF, nominal.

V. Doors and Gates

1. The restroom entry doors shall be 7' 0" high, 14-gauge steel; reinforced with 14 gauge steel ribs welded at 6" intervals on each face, concealed; reinforced with a welded plate for door closer mounting
2. Doors shall be hung on a single continuous, 1 million cycle, aluminum gear hinge with stainless steel vandal resistant screws at nominal 4" on center. The doors shall weigh nominally 176 lbs each for a 36" X 84" door. Custom fabricated 14-gauge steel door jambs with 4" steel heads shall be welded to the steel cap beam and be solid filled with 3000 psi masonry grout mix. Doors shall be primed and painted with two coats of industrial enamel; color selected by owner.
3. All exterior entry doors shall have a ¼" thick stainless steel "Z-shaped" anti-microbial pull handles with integral latch guard and **SCHLAGE B600 series temporary large format core locks**. The interior push-plate shall be anti-microbial for public safety and hygiene.
4. The door closer (restroom and concession entry doors only) shall be "LCN" heavy duty #4210 Series, fastened to a structural reinforced door plate per door manufacturer design. Stainless steel vandal resistant fasteners shall be used on all hardware.
5. Stainless steel vandal resistant fasteners shall be used on all hardware.

W. Specialties

1. All specialty washroom equipment shall be commercial grade stainless steel fastened securely to walls with vandal resistant stainless-steel screws to avoid removal by vandals as follows:
2. Toilet paper holders shall be **Royce Rolls TP-3, three-roll** stainless steel. Toilet paper holders shall be attached to block walls with 4 epoxy-bedded vandal resistant stainless steel fasteners.
3. Stainless steel grab bars to code shall be 1 ¼" minimum exposed fastener vandal resistant design and installed at each accessible water closet.
4. Cast Aluminum California compliant signage shall be recessed into block surface flush with masonry/stucco exterior and door sign shall be blind fastened with epoxy adhesive and stainless-steel fasteners. Wall signs shall have raised pointed Braille tips. Signage shall comply with AB1732, identifying the restrooms as "All Gender Restrooms."
5. Stainless steel baby-changing stations (**Foundations Model 200-EH-1**) shall be mounted in each accessible restroom with identifying signage on the exterior adjacent to the restroom signage.
6. Electronically adjustable **Adult Changing stations (Koala KB-3000-AHL)** shall be mounted in one accessible restroom with identifying signage on the exterior adjacent to the restroom signage.

X. Plumbing:

-
1. Building shall be fully compliant with current with the following codes:
 - a) All applicable State of California Building Codes. Latest edition applicable.
 - b) California Plumbing Code. Latest edition applicable.
 2. GENERAL: All components and fabrications shall be designed to reduce life cycle maintenance, be compatible with current maintenance spare parts, and shall be listed in a spare parts/maintenance manual (two copies) delivered in utility chase of building.
 3. WATER PIPING: Shall be type L **copper** soldered per code above grade and type K with silver solder below grade. All water piping shall be designed and constructed with high and low point drain fittings. All piping shall be mounted on Uni-strut wall brackets with neoprene isolators, to code.
 4. WATER PRESSURE GAUGE/VALVE COMBO: install three commercial grade industrial water pressure gauges (one on incoming line, one at pressure regulator valve and one after water filter), isolation ball valves, 150 PSI pressure regulator with wye strainer, 10-micron water filter with clear canister, and check valve. System will also incorporate a **ProFlo PFXT5 Bladder Tank** for additional plumbing protection.
 5. PLUMBING FAUCETS, ISOLATION VALVES AND ACTUATORS: All fixtures except those with flush valves shall be isolated with ball valves for each fixture, concealed hydraulic push-button flush valves, and metered push-button lavatory faucets.
 6. DWV PIPING: DWV piping shall be concealed behind the wall. DWV piping shall be PVC DWV, solvent welded, for all concealed piping. A cast iron no hub DWV vent pipe with a cast iron roof mounted vandal cap vent shall be required, through the roof.
 7. REMOVABLE PIPE TRAPS: all floor drain, sink drain, and waste traps shall be removable for maintenance. Floor drains shall be trapped behind the wall in the utility chase using a combination waste and vent system. Floor drains shall be increased two pipe sizes over standard to allow code use. Trap primers for restroom floor drains shall be in the utility chase. All surface mounted utility chase piping shall be mounted on Uni-strut with plastic isolators to code. Sink drain traps shall be concealed behind the utility chase walls where maintenance staff can access all plumbing.
 8. PLUMBING FIXTURES: Plumbing fixtures shall be 14-gauge, 316 stainless steel manufactured by Acorn. Toilets shall be wall hung, rear discharge, with concealed, ADA-compliant, hydraulic push-button type, flush valves. Toilet seats shall be black solid core plastic, non-flammable construction with continuous stainless steel concealed self-checking hinges. Exterior Lavatories shall have concealed remote traps behind the mechanical wall. Schedule of fixtures:
 - a. **Water Closets: Acorn Penal-Ware, 1675-W-1-HET-FVBO-ADA-PFS-316SS**
 - b. **Water Closet Flush Valve: Zurn ZH6152AV-HET-7L-BG**
 - c. **Lavatories: Acorn Penal-ware 1652LRB-1-DMS-03-M-316SS**
 - d. **Lavatory Faucet: Chicago MVP 333-E2805-665PSHABCP-TEMPERED**
 - e. **Soap Dispensers: PRC Through Wall SS Tank W/Lav Dispensers**

-
- f. Countertops: 14 Ga. 304 Stainless Steel (where applicable)**
 - g. Hand Driers: Dyson Airblade V**

- 9. FLOOR GRATES: Removable 350 lbs. per square foot pultruded fiberglass non-skid floor grates shall be installed over every opening in the utility chase for OSHA compliance.
- 10. HOSE BIB: There shall be **one** Acorn 8121-LF hose bib provided in the utility chase.
- 11. HOSE REEL: **with 5/8"x75" Garden Hose**
- 12. HI-LO DRINKING FOUNTAIN: **HAWS 1109.14**
- 13. BOTTLE FILLER: **HAWS #1920 & #6469**
- 14. Electrical J-Box: Located in the Chase.**
- 15. Alternative Natural Lighting: 4x Solartubes (10" std)**

Y. Shipping Protection

The building, while traveling over roads to the destination may encounter inclement weather or road grime that could require substantial cleaning when it arrives on site. The building shall be shrink-wrapped before transportation and sufficiently strong to arrive at the owner site intact for exterior finish protection. Materials removed on site shall be disposed of and recycled by restroom building install staff.

Z. Certifications

Building shall be certified in compliance with the plan approval by the State of California, Department of Housing and Community Development. The building shall be delivered with an applied insignia, in compliance with all State regulations. The local building authority shall provide site inspections for the underground mechanical piping and final connections, footings, and access issues outside the restroom footprint. Restroom building subcontractor shall also furnish 5-year component/20-year structural warranty and maintenance manuals for the building and components.

END OF SECTION



SPECIFICATIONS

Project #: 11602
 Project Name: Jollyman Park
 Site Address: 1000 S Steling Rd
 City, State, Zip: Cupertino, CA CALIFORNIA

Date: 3/24/2024
 Bldg Size: See Drawings
 Type of Bldg: PS-022-DF-BF-ST
 Restroom/Storage

TYPE OF BUILDING

Construction Type

MVR WOOD	Wood Framed walls above cap beam, and wood framed rafters [ceiling & vents same as MVR]
-----------------	---

FLOOR SYSTEM

ROOM/ITEM	FINISH
Entire Building	Exposed Concrete with Light Broom Finish with Integral Additive for Stain/Moisture Resistance
Entire Building	Floor Coating with Skid Resistant Additive - Flakes

WALL SYSTEM

BUILDING WALLS HEIGHT	
Building Walls Height	7'4"

EXTERIOR WALLS - CMU	BLOCK TYPE AND COLOR	ROWS
Precision Exterior 4" CMU	Precision Gray	All

CAP BEAM	
Cap Beam	Cap Beam, Steel Tube, Painted

WALL FINISHES - EXTERIOR

TYPE	FINISH	HEIGHT
CMU	Uncoated	To Cap Beam
FRC Siding -Below- Cap Beam	Allura Cedarmill Board & Batt Siding Vertical - Painted	To Cap Beam
Siding -Above- Cap Beam	7/8" 24 GA Corrugated Metal Prefinished	Above Cap Beam
Alcove	Precision CMU Painted	To Cap Beam
Exterior Paint	PPG Exterior Gloss - Colors TBD by client	

WALL FINISHES - INTERIOR

ROOM	FINISH	HEIGHT
Restrooms Below Cap Beam	Block filler & paint	To Cap Beam
Restrooms - Above Cap Beam	Stucco Pattern FRC - Painted	Above Cap Beam
Mechanical - To Cap Beam	Block filler & paint	To Cap Beam
Mechanical - Above Cap Beam	Painted OSB	Above Cap Beam
Storage - To cap Beam	Block filler & paint	To Cap Beam
Storage - Above Cap Beam	Painted OSB	Above Cap Beam
Behind Mop Sink	Block Filler & Epoxy Paint	To Cap Beam

ROOF SYSTEM

ITEM	DESCRIPTION	SIZE
Metal Sales Image II 26 GA	26 GA SSM, Metal Sales Image II Standing Seam With 16" Striations W/Ice & Water	
Entire Building Ceiling	(MVR) 5/16" Cement Board Stucco Pattern Over 5/8" OSB	
Fascia	14/16 Ga Formed Galvanized Steel W/1" Return At Top (MVR)	
Vents SS Wire Mesh	Stainless Steel Wire Mesh	
ITEM	DESCRIPTION	SIZE
Skylights	Solatubes (10" std)	

DOORS - HARDWARE

ITEM	DESCRIPTION
Fiber Glass	Fiberglass Door with Fiberglass Frame
Double Door (Storage Area)	Fiberglass
Deadbolt	SCHLAGE B600 series temporary large format core (std)

ITEM	DESCRIPTION	LOCATION
Pull Plates	Rockwood-VRT24 "Z" (Standard w/Anti-Microbial) (Std)	
Door Closer	LCN Closer, Model # 4211 Cush Arm (for Out Swing Door)	Restroom
Weather Strip	Pemko Perimeter Gasketing (3' x 7' Door) # 303-C-S-3684	Chase
Door Sweeps	NGP Door Sweep 200NA36	Chase
Door Threshold (No Tile)	Threshold Fluted Saddle Mill Finish Alum, 4" Wide #270A36	All
Ives Crash Chain (Standard)	Ives Crash Chain, # CS11526D20, US26D, 20.5, Crash Stop	Chase
Door Kick Plates (Both Sides)	Rockwood Metal Kick Plate, # K1050 10" x 33"	Restroom/ST

RESTROOM ACCESSORIES

ITEM	MANUFACTURER/DESCRIPTION	FINISH
Signage	Door/Wall Signs	Polished Aluminum & Blue
Grab Bars	Grab Bars	Stainless Steel
Aluminum Louvers (Chase Std)	Louver Sunvent Industries Model #157	Polished Aluminum
Toilet Paper Holders	Tough Guy - #4YRE5	Stainless Steel
Baby Changing Station	Foundations 200-EH-1	Stainless Steel
Adult Changing Station	Koala Kare LB3000-AHL	
Hand Dryer	Fastaire HD03S Hand Dryer (Short)	

ITEM	MANUFACTURER/DESCRIPTION
Utility Hook (Standard)	Utility Hook, Bright Finish, Bobrick # B-670-PRC or Franklin Brass 5501 for Blazer
Sanitary Napkin Disposal	Bobrick B-2706C
Soap Dispenser	PRC Proprietary Tank
W/Thru Wall Valve	Thru Wall Valve ASI #353

RESTROOM SPECIALTY ITEMS

ITEM	SIZE	DESCRIPTION	FINISH
Shelving		Bobrick B-296	Chrome

PLUMBING

FIXTURE/PART	DESCRIPTION
Toilets - Stainless Steel	Acorn # 1675 W-1-HET 1.28 GPF-FVBO-ADA-PFS-316SS
Lavs - Stainless Steel	Rear Connect Acorn # 1652LRB-1-DMS-03-M-316SS
Drinking Fountain	Wall Mounted Drinking Fountain, 14 Gauge, Type 304 Stainless Steel, Haws Model # 1109.14
Remote Water Chiller	Remote Water Chiller, with Shelf, 8 Gallons P/Hr. Model # A9100080-A-SRC
Bottle Filler	Wall Mounted Bottle Filler, Lead Free, Type 304 Stainless Steel, Haws Model # 1920
Sensor - Toilet Flush Valve	Zurn Flush Valve 1.28 Ga Zurn # ZEMS6152AV-HET-7L-1.28
Sensor Faucets	Zurn Sensor Faucet # Z6913-XL-CWB-F Aquasense
Floor Drains: W/Trap Primer	Floor Drain Zurn # ZN460-2NH-5B W/Strainer / With Trap Primer

PLUMBING SPECIAL

FIXTURE/PART	DESCRIPTION
Floor Mount Mop Sink	Mustee Mop Service Basin, Model # 63M 24" x 24" x 10", Color: White
Mop Rack	ProFlo PF245: Mop Hanger

PLUMBING GENERAL

FIXTURE/PART	DESCRIPTION	
Water Heater	Stiebel DHC-E3	1 lavatory
Water Heater	Stiebel DHC-E8	1-2 lavatories

Tempered Water to Lavs	Thermostatic Mixing Valve, Acorn Model # ST70-12
Valve Combo (PRV)	Valve Combo with Pressure Reducing Valve
Water Line Material	Copper (Std)
Bladder Tank	ProFlo PFXT5, (PRC)/ Amtrol 2 gal (Blazer) - no elect required
Hose Bibb- Interior	Acorn #8121-LF - in the Chase
Hose Reel & Hose	Hose Reel With 5/8"x75' Garden Hose

ELECTRICAL

ITEM	DESCRIPTION	LOCATION
Electrical Panel	100 amp Single Phase - 120/240 v	20 Circuits
Breakers	Plug on (QOD)	

LIGHTING

ITEM	DESCRIPTION (W=WALL, C=CEILING)	WATTS
Lighting Control -Interior-	Light Fixture Integrated Occupancy Sensor (OCC)	
Interior Lights	W/C) Luminaire, Swoop Series SWP1212-OP-BRZ-OCC	15 Watts
Lighting Control -Exterior-	Photo Cell Intermatic Photo Control #EK4336S	
Exterior Light	W/C) Luminaire, Swoop Series SWP-610-OP-BRZ	15 Watts
Exterior Lights	W) Luminaire, AEL-12 (Dark Sky Compliant) 20" long	10 Watts
Chase Lights	C) Green AL-42L (large Chase)Waterproof	30 Watts

RECEPTACLES/SWITCHES, HEATERS, FANS, HVAC, LIGHTED SIGNS

ITEM	DESCRIPTION	LOCATION
Receptacles	GFCI (Adjacent to Panel)	
Receptacles	GFCI	
Switches Single Pole	Single Pole (Adjacent to Panel)	
Switches By Pass	By Pass (To By Pass OCC Sensors)	
Emergency Light	Lithonia ELM2L Led 2 Head Led Emergency Light (Mechanical Room)	



FLOOR PLAN

SCALE: NOT TO SCALE

THIS CONCEPTUAL/ PRELIMINARY DESIGN AND THE 3D RENDERING IS AN ARTISTIC INTERPRETATION OF THE DESIGN. IT IS NOT MEANT TO BE AN EXACT RENDITION OF THE FINISH PRODUCT. SOME ITEMS MAY NOT BE STANDARD AND/OR SUBJECT TO CHANGE DURING PROJECT DEVELOPMENT

PARK JOLLYMAN CUPERTINO, CALIFORNIA RESTROOM BUILDING
 COPYRIGHT 2024, PUBLIC RESTROOM COMPANY
 THIS MATERIAL IS THE EXCLUSIVE PROPERTY OF PUBLIC RESTROOM COMPANY AND SHALL NOT BE REPRODUCED, USED OR DISCLOSED TO OTHERS EXCEPT AS AUTHORIZED BY THE WRITTEN PERMISSION OF PUBLIC RESTROOM COMPANY.



PUBLIC RESTROOM COMPANY
 Building Better Places To Go.™

www.PublicRestroomCompany.com
 2587 BUSINESS PARKWAY
 MIDDEH NEVADA 89423
 P: 888-888-2060 F: 888-888-1446

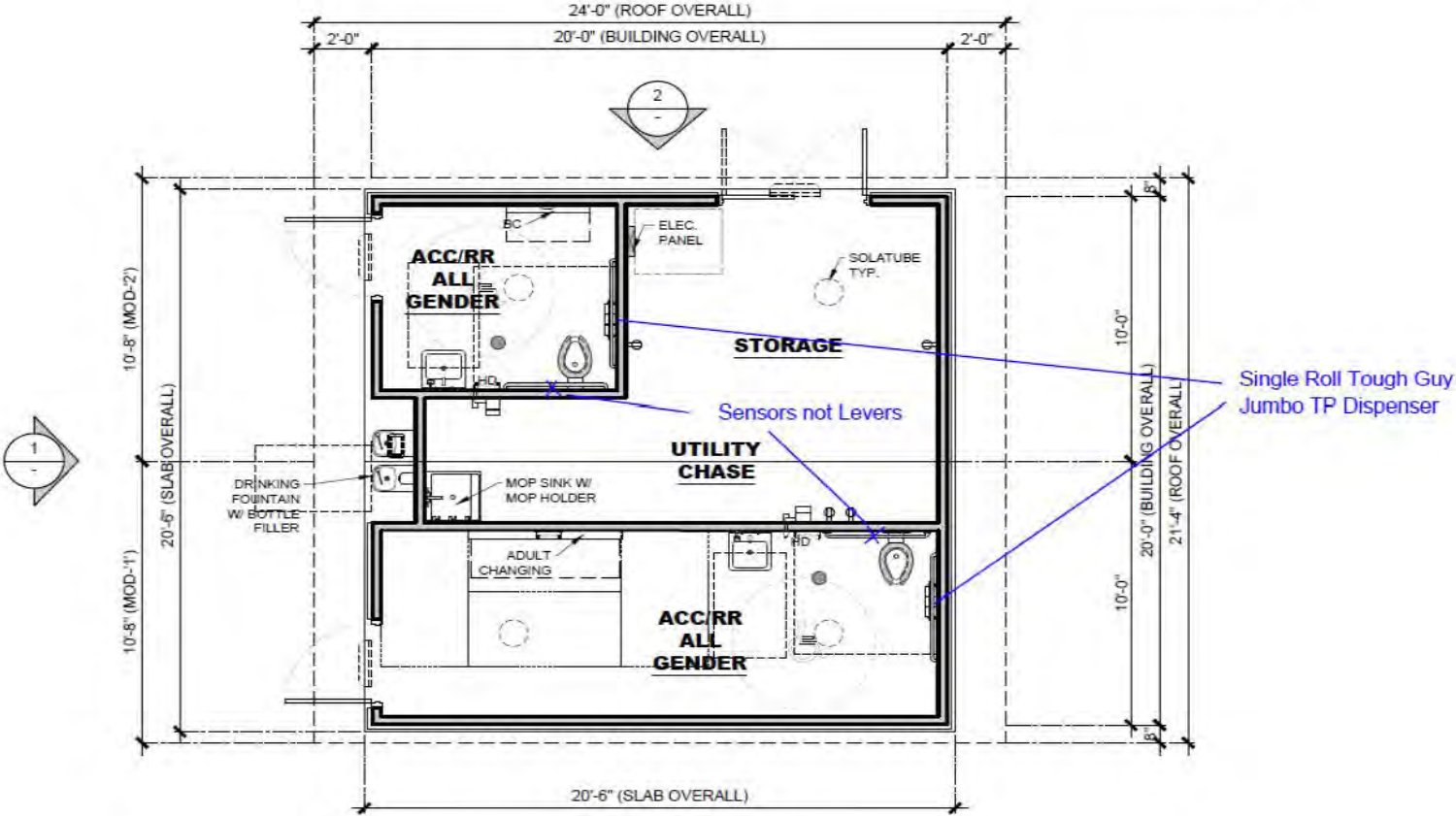

FLOOR PLAN

SCALE: 3/16"=1'-0"

THIS CONCEPTUAL/ PRELIMINARY DESIGN AND THE 3D RENDERING IS AN ARTISTIC INTERPRETATION OF THE DESIGN. IT IS NOT MEANT TO BE AN EXACT REPRESENTATION OF THE FINISH PRODUCT. SOME ITEMS MAY NOT BE STANDARD AND / OR SUBJECT TO CHANGE DURING PROJECT DEVELOPMENT

 PUBLIC RESTROOM COMPANY Building Better Places To Go.™	COPYRIGHT 2024, PUBLIC RESTROOM COMPANY THIS MATERIAL IS THE EXCLUSIVE PROPERTY OF PUBLIC RESTROOM COMPANY AND SHALL NOT BE REPRODUCED, USED, OR DISCLOSED TO OTHERS, EXCEPT AS AUTHORIZED BY THE WRITTEN PERMISSION OF PUBLIC RESTROOM COMPANY.	BUILDING TYPE:	RESTROOM BUILDING	REVISION #	1	REVISION DATE:	3/14/2024	SHEET#	A-1
		PROJECT:	JOLLYMAN PARK CUPERTINO, CA	PROJECT #:	11602	START DATE:	3/13/2024	MAX. PERSON / HOUR:	90 S

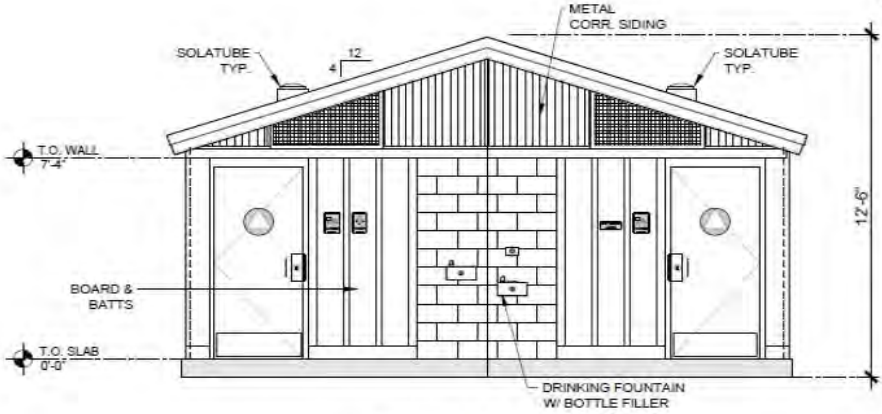

ELEVATION 1

SCALE: 3/16"=1'-0"

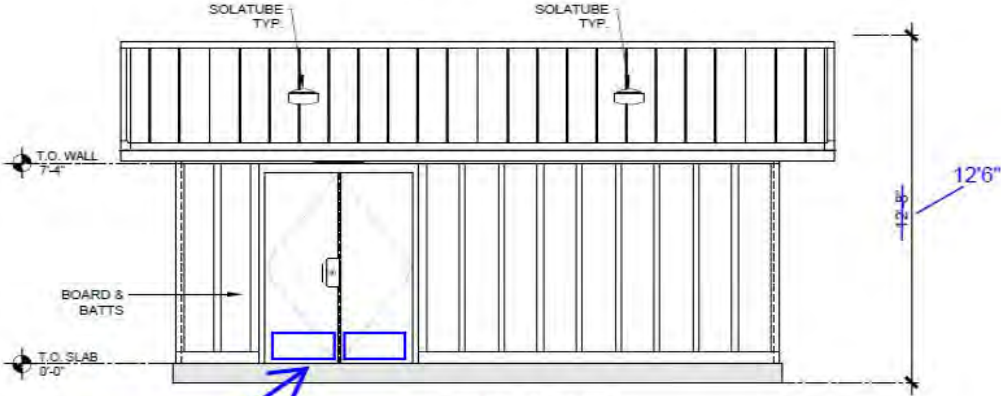

ELEVATION 2

SCALE: 3/16"=1'-0"

Add kick plates to all doors
interior and exterior

THIS CONCEPTUAL/ PRELIMINARY DESIGN AND THE 3D RENDERING IS AN ARTISTIC INTERPRETATION OF THE DESIGN. IT IS NOT MEANT TO BE AN EXACT REPRESENTATION OF THE FINISH PRODUCT. SOME ITEMS MAY NOT BE STANDARD AND / OR SUBJECT TO CHANGE DURING PROJECT DEVELOPMENT

 PUBLIC RESTROOM COMPANY Building Better Places To Go.™	COPYRIGHT 2024. PUBLIC RESTROOM COMPANY THIS MATERIAL IS THE EXCLUSIVE PROPERTY OF PUBLIC RESTROOM COMPANY AND SHALL NOT BE REPRODUCED, USED, OR DISCLOSED TO OTHERS EXCEPT AS AUTHORIZED BY THE WRITTEN PERMISSION OF PUBLIC RESTROOM COMPANY.	BUILDING TYPE:	RESTROOM BUILDING	REVISION #	1	REVISION DATE:	3/14/2024	SHEET#	A-2
		PROJECT:	JOLLYMAN PARK CUPERTINO, CA	PROJECT #:	11602	START DATE:	3/13/2024	MAX. PERSON / HOUR:	90 S
PR: 888-888-8285 FX: 888-888-1428		--NOT FOR CONSTRUCTION -- PRELIMINARY DESIGN DRAWING ONLY -- DO NOT SCALE. DIMENSIONS PRECISE							

OWNER / GENERAL CONTRACTOR AND PUBLIC RESTROOM COMPANY RESPONSIBILITIES

PUBLIC RESTROOM COMPANY RESPONSIBILITIES:

1. PROVIDE FULL ARCHITECTURAL PLANS AND ENGINEERING CALCULATIONS, STAMPED BY STATE GOVERNING AGENCY SUITABLE FOR GENERAL CONTRACTOR TO FILE FOR REQUIRED BUILDING PERMIT.
2. FURNISH AND INSTALL UNDERGROUND UTILITIES UNDER SLAB (INCLUDING TRENCHING) EXTENDING 6 FEET MAX. BEYOND THE BUILDING LINE, MIN. OF 24" - MAX OF 36" BELOW GRADE.
3. FURNISH AND INSTALL SLAB TO FOUNDATION ANCHORS PER DETAILS INCLUDED HEREIN. APPLICABLE ONLY TO BUILDINGS WITH FOUNDATIONS.

GENERAL NOTES:

1. THE DIFFERENCE IN THE ELEVATION BETWEEN THE FINISH FLOOR OF THE BUILDING AT EXTERIOR DOORS AND THE SIDEWALK OUTSIDE IS 1/4" MAX. PRC RECOMMENDS SIDEWALK TO BE FLUSH WITH FINISH FLOOR AT ALL DOORS.
2. THE PLAN & DETAILS HEREIN ARE SPECIFIC TO THE BUILDING SIZE AND MODULE CONFIGURATION OF THIS BUILDING MODEL.

OWNER / GENERAL CONTRACTOR RESPONSIBILITIES:

1. PREPARE BUILDING PAD AND OR FOUNDATION.
2. PROVIDE SITE PLAN & ENGINEERED FOUNDATION PLAN (IF APPLICABLE) AND ATTACH IT TO THE PUBLIC RESTROOM COMPANY'S DEPARTMENT OF HOUSING APPROVED DOCUMENTS AND OBTAIN NECESSARY PERMITS FROM LOCAL JURISDICTION.
3. VERIFY AND SCHEDULE NECESSARY INSPECTIONS WITH LOCAL JURISDICTION FOR SITE PERFORMED WORK BY OTHERS, AND FOR UNDER BUILDING SLAB PLUMBING CONNECTIONS MADE BY PRC.
4. COORDINATE SEWER INVERT ELEVATION WITH THE PUBLIC RESTROOM COMPANY PRIOR TO BUILDING INSTALLATION, VERIFY & COORDINATE LOCATION OF EXISTING UTILITIES INCLUDING WATER METER SIZE, TYPE, AND LOCATION OF EXISTING UTILITIES COMING INTO THE BUILDING SUPPLIED BY PRC
5. MAKE FINAL UTILITY CONNECTIONS (INCLUDING NECESSARY UTILITY BOXES).
6. PREPARE SITE FOR MINIMUM ALLOWABLE SOIL BEARING PRESSURE OF 1,500 psf, WITH SUB-GRADE COMPACTED TO 90% M.D.D.
7. SUPPLY AND STOCK PILE REQUIRED QUANTITY OF COARSE MASON SAND WITHIN BUILDING PROXIMITY FOR USE BY PRC FOR UTILITY TRENCH BACKFILL.
8. PROJECTS WITH FOOTINGS: PROVIDE SLEEVES IN FOOTINGS ACCORDING TO UTILITY LOCATION PLAN AND PAD / FOUNDATION PLAN DIRECTION.

GENERAL SITE CONDITION LIABILITY NOTE:

PUBLIC RESTROOM COMPANY (PRC) PROVIDES BUILDING PAD / FOUNDATION PLAN DRAWINGS FOR PLACEMENT OF OUR BUILDING ON SITE FOUNDATIONS / PADS FOR **REFERENCE ONLY**. PRC DRAWINGS DO NOT INCORPORATE SITE DESIGN FOR LOCAL CODES, SOILS CONDITIONS, FOOTING REQUIREMENTS, AND / OR ANY OTHER CONTRIBUTING SITE FACTORS UP TO AN INCLUDING HIGH WATER TABLES. IT IS THE RESPONSIBILITY OF THE OWNER / GENERAL CONTRACTOR TO PROVIDE A PROPER SITE DESIGN TO ACCOMMODATE THE BUILDING AS WELL AS PROVIDE PROPER SITE CRITERIA SO PRC MAY MODEL SEWER, WATER, AND ELECTRICAL DESIGNS WITHIN THE BUILDING. OUR BUILDING DESIGN INCLUDES AN 8" THICK REINFORCED CONCRETE SLAB AND ASSUMES FULL SLAB BEARING ON SOILS WITH A MINIMUM OF 1500 PSF BEARING CAPACITY. OUR BUILDING DESIGNS SURCHARGE THE SOIL BENEATH THE MAT SLAB AT APPROXIMATE 208 PSF. ANY BUILDING FOUNDATION IN ADDITION TO THE INTEGRAL MAT SLAB ARE SHOWN FOR **REFERENCE ONLY** AND SHOULD BE VERIFIED BY A LICENSED SOILS ENGINEER TO CONFORM WITH REQUIRED CODES.

PRC ASSUMES NO LIABILITY FOR THE OWNER OR GENERAL CONTRACTOR ACCEPTANCE OF THESE TYPICAL DRAWINGS WITHOUT VERIFICATION BY A LICENSED SOILS / FOUNDATION ENGINEER.



COPYRIGHT 2021, PUBLIC RESTROOM COMPANY THIS MATERIAL IS THE EXCLUSIVE PROPERTY OF PUBLIC RESTROOM COMPANY AND SHALL NOT BE REPRODUCED, USED, OR DISCLOSED TO OTHERS EXCEPT AS AUTHORIZED BY THE WRITTEN PERMISSION OF PUBLIC RESTROOM COMPANY.

BUILDING TYPE:

RESTROOM BUILDING

PROJECT:

-

DATE: - DRAWN BY:

PROJECT #: -

SHEET:

FD-1

1 OF 4

NOTES:

1. BOTTOM OF PRE-FAB BLDG. MANUFACTURERS SLAB IS DEAD FLAT. TOP OF FOOTINGS & COMPACTED BACK FILL MUST BE DEAD LEVEL. POUR FOOTING WITH LASER TRANSIT TO VERIFY TOP OF FOOTING. IF SHIM PLATES ARE REQUIRED A CHANGE ORDER IS REQUIRED.
2. REQUIRED ALLOWABLE SOIL BEARING PRESSURE = 1500 PSF; FIELD VERIFIED BY OTHERS

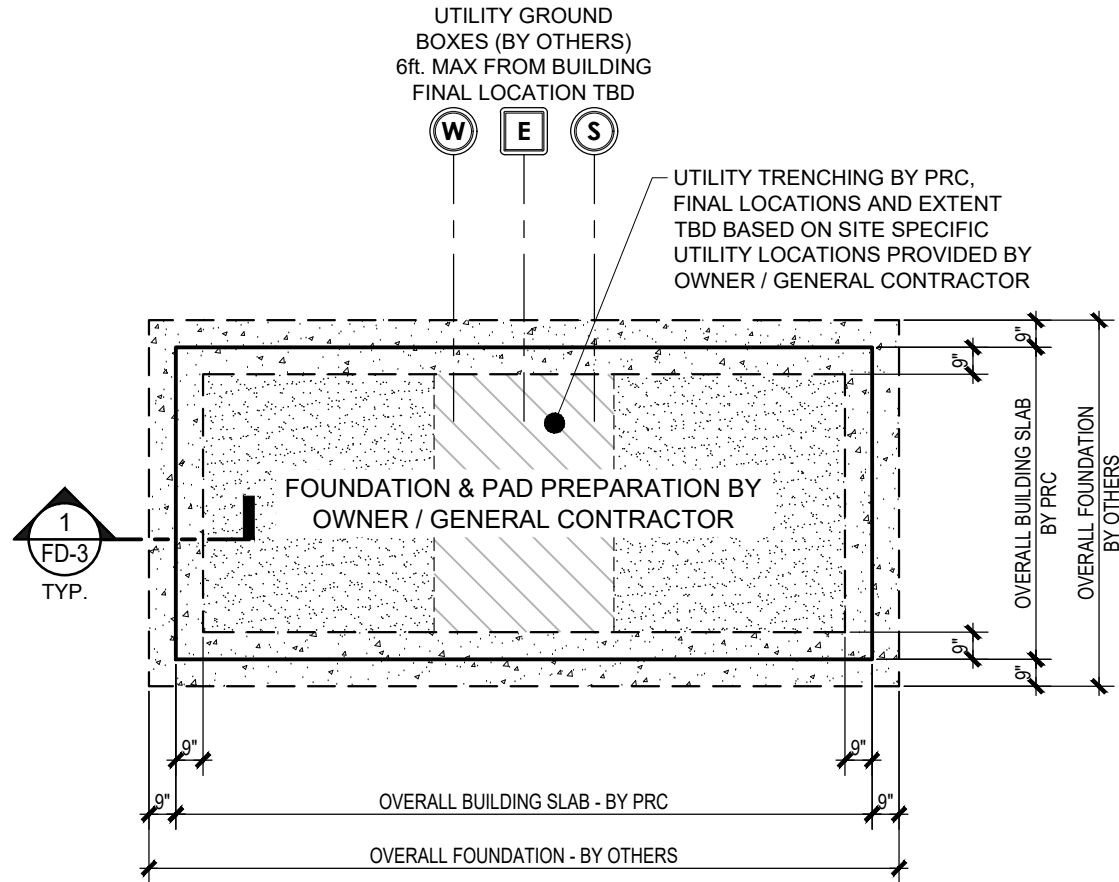

1
FD-2

EXAMPLE FOUNDATION / PAD PREPARATION PLAN
SCALE: NOT TO SCALE

EXAMPLE FOR REFERENCE ONLY



COPYRIGHT 2021, PUBLIC RESTROOM COMPANY THIS MATERIAL IS THE EXCLUSIVE PROPERTY OF PUBLIC RESTROOM COMPANY AND SHALL NOT BE REPRODUCED, USED, OR DISCLOSED TO OTHERS EXCEPT AS AUTHORIZED BY THE WRITTEN PERMISSION OF PUBLIC RESTROOM COMPANY.

BUILDING TYPE:

RESTROOM BUILDING

PROJECT:

DATE: - DRAWN BY:

PROJECT #: -

SHEET:

FD-2

2 OF 4

NOTES:

1. BOTTOM OF PRE-FAB BLDG. MANUFACTURERS SLAB IS DEAD FLAT. TOP OF FOOTINGS & COMPACTED BACK FILL MUST BE DEAD LEVEL. POUR FOOTING WITH LASER TRANSIT TO VERIFY TOP OF FOOTING. IF SHIM PLATES ARE REQUIRED A CHANGE ORDER IS REQUIRED.

2. REQUIRED ALLOWABLE SOIL BEARING PRESSURE = 1500 PSF; FIELD VERIFIED BY OTHERS

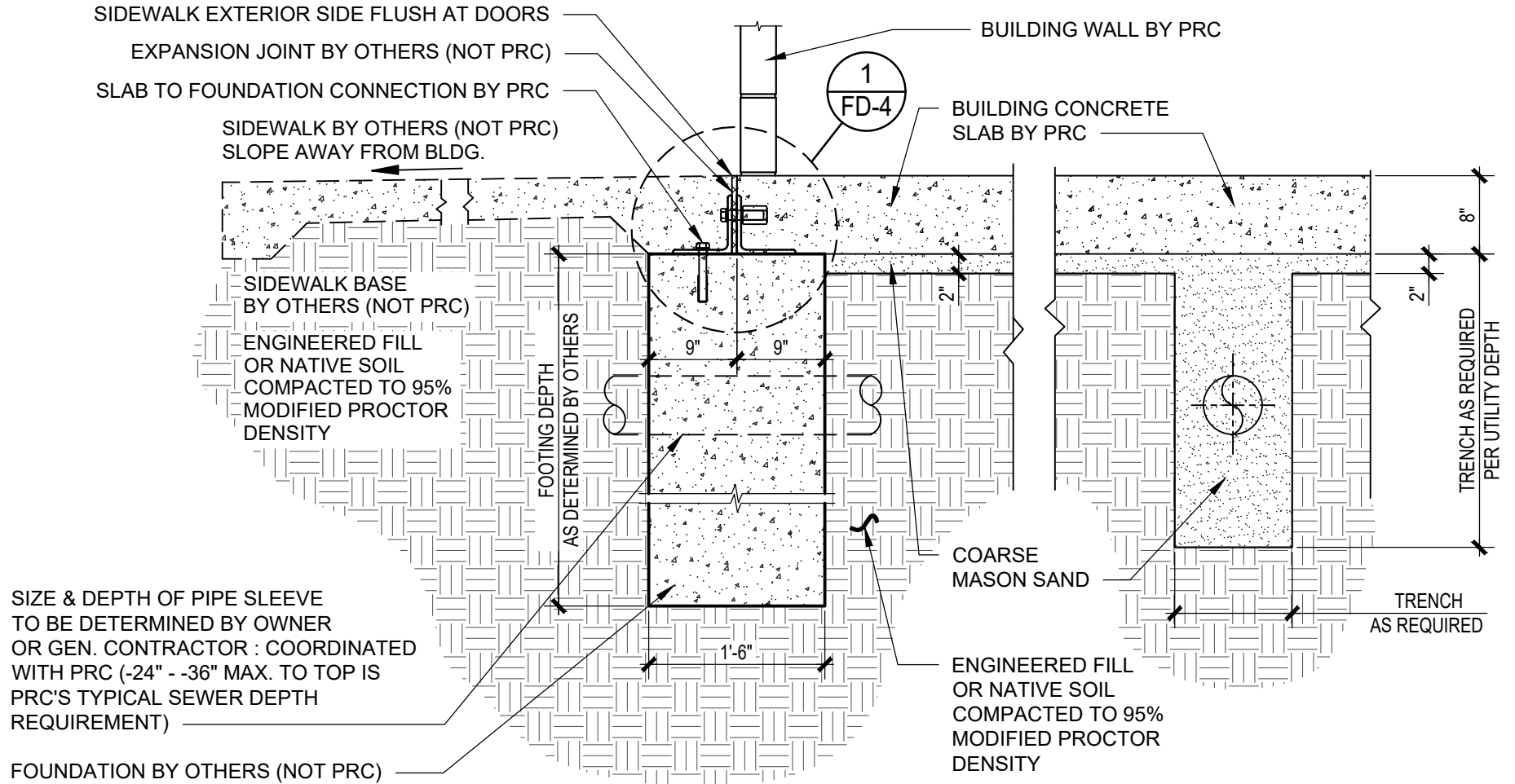

1
FD-3 **TYPICAL FOUNDATION SECTION DETAIL**
SCALE: NOT TO SCALE



COPYRIGHT 2021, PUBLIC RESTROOM COMPANY THIS MATERIAL IS THE EXCLUSIVE PROPERTY OF PUBLIC RESTROOM COMPANY AND SHALL NOT BE REPRODUCED, USED, OR DISCLOSED TO OTHERS EXCEPT AS AUTHORIZED BY THE WRITTEN PERMISSION OF PUBLIC RESTROOM COMPANY.

BUILDING TYPE:

RESTROOM BUILDING

PROJECT:

DATE: - DRAWN BY:

PROJECT #: -

SHEET:

FD-3

3 OF 4

NOTE:
QUANTITY AND LOCATIONS OF ANCHORS TO BE DETERMINED BY PRC ENGINEER

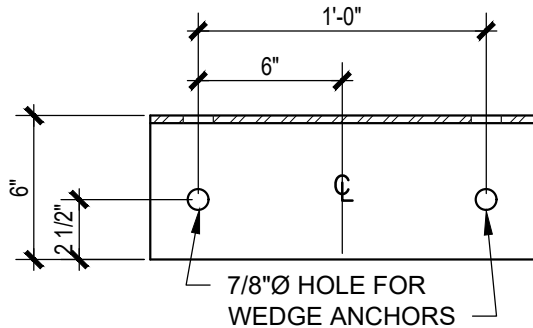

TOP VIEW

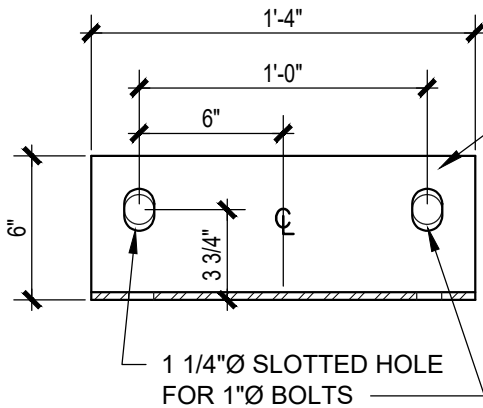

FRONT VIEW

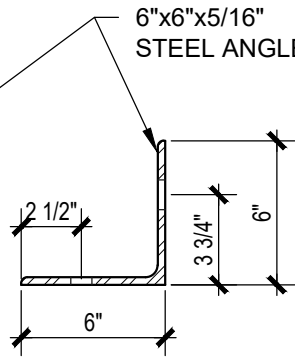

SIDE VIEW

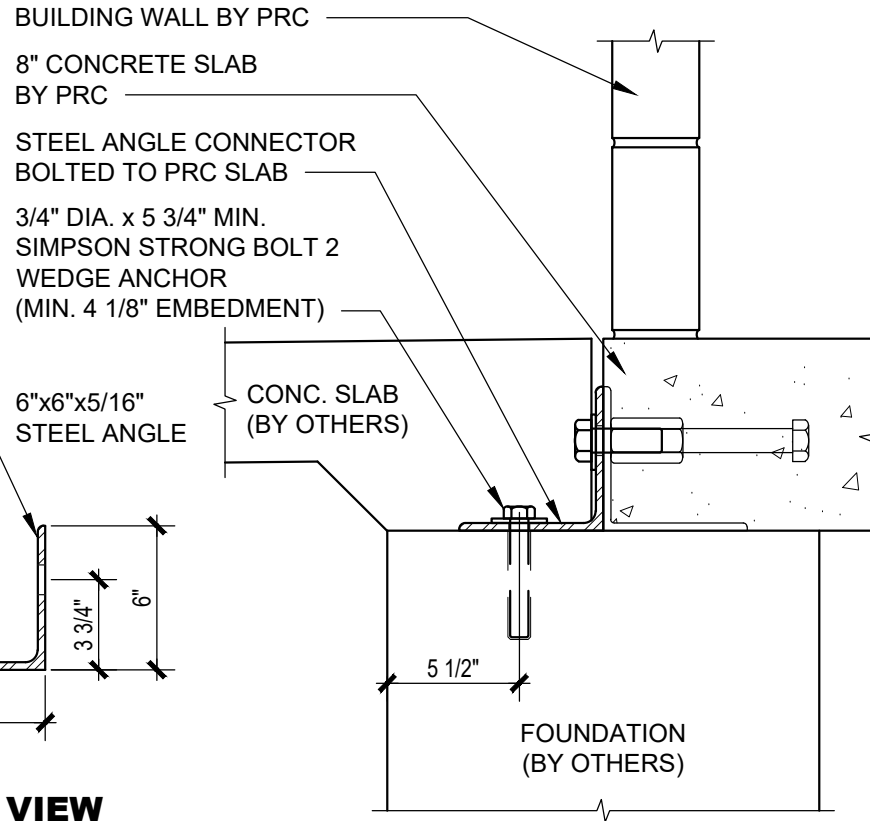

1
FD-4

SLAB TO FOUNDATION ANCHOR DETAIL (BY PRC)

SCALE: NOT TO SCALE



COPYRIGHT 2021, PUBLIC RESTROOM COMPANY THIS MATERIAL IS THE EXCLUSIVE PROPERTY OF PUBLIC RESTROOM COMPANY AND SHALL NOT BE REPRODUCED, USED, OR DISCLOSED TO OTHERS EXCEPT AS AUTHORIZED BY THE WRITTEN PERMISSION OF PUBLIC RESTROOM COMPANY.

BUILDING TYPE:

RESTROOM BUILDING

PROJECT:

DATE: - DRAWN BY:

PROJECT #: -

SHEET:

FD-4

4 OF 4

OWNER / GENERAL CONTRACTOR AND PUBLIC RESTROOM COMPANY RESPONSIBILITIES

PUBLIC RESTROOM COMPANY RESPONSIBILITIES:

1. PROVIDE FULL ARCHITECTURAL PLANS AND ENGINEERING CALCULATIONS, STAMPED BY STATE GOVERNING AGENCY SUITABLE FOR GENERAL CONTRACTOR TO FILE FOR REQUIRED BUILDING PERMIT.
2. FURNISH AND INSTALL UNDERGROUND UTILITIES UNDER SLAB (INCLUDING TRENCHING) EXTENDING 6 FEET MAX. BEYOND THE BUILDING LINE, MIN. OF 24" - MAX OF 36" BELOW GRADE.
3. FURNISH AND INSTALL SLAB TO FOUNDATION ANCHORS PER DETAILS INCLUDED HEREIN. APPLICABLE ONLY TO BUILDINGS WITH FOUNDATIONS.

GENERAL NOTES:

1. THE DIFFERENCE IN THE ELEVATION BETWEEN THE FINISH FLOOR OF THE BUILDING AT EXTERIOR DOORS AND THE SIDEWALK OUTSIDE IS 1/4" MAX. PRC RECOMMENDS SIDEWALK TO BE FLUSH WITH FINISH FLOOR AT ALL DOORS.
2. THE PLAN & DETAILS HEREIN ARE SPECIFIC TO THE BUILDING SIZE AND MODULE CONFIGURATION OF THIS BUILDING MODEL.

OWNER / GENERAL CONTRACTOR RESPONSIBILITIES:

1. PREPARE BUILDING PAD AND OR FOUNDATION.
2. PROVIDE SITE PLAN & ENGINEERED FOUNDATION PLAN (IF APPLICABLE) AND ATTACH IT TO THE PUBLIC RESTROOM COMPANY'S DEPARTMENT OF HOUSING APPROVED DOCUMENTS AND OBTAIN NECESSARY PERMITS FROM LOCAL JURISDICTION.
3. VERIFY AND SCHEDULE NECESSARY INSPECTIONS WITH LOCAL JURISDICTION FOR SITE PERFORMED WORK BY OTHERS, AND FOR UNDER BUILDING SLAB PLUMBING CONNECTIONS MADE BY PRC.
4. COORDINATE SEWER INVERT ELEVATION WITH THE PUBLIC RESTROOM COMPANY PRIOR TO BUILDING INSTALLATION, VERIFY & COORDINATE LOCATION OF EXISTING UTILITIES INCLUDING WATER METER SIZE, TYPE, AND LOCATION OF EXISTING UTILITIES COMING INTO THE BUILDING SUPPLIED BY PRC
5. MAKE FINAL UTILITY CONNECTIONS (INCLUDING NECESSARY UTILITY BOXES).
6. PREPARE SITE FOR MINIMUM ALLOWABLE SOIL BEARING PRESSURE OF 1,500 psf, WITH SUB-GRADE COMPACTED TO 90% M.D.D.
7. SUPPLY AND STOCK PILE REQUIRED QUANTITY OF COARSE MASON SAND WITHIN BUILDING PROXIMITY FOR USE BY PRC FOR UTILITY TRENCH BACKFILL.
8. PROJECTS WITH FOOTINGS: PROVIDE SLEEVES IN FOOTINGS ACCORDING TO UTILITY LOCATION PLAN AND PAD / FOUNDATION PLAN DIRECTION.

GENERAL SITE CONDITION LIABILITY NOTE:

PUBLIC RESTROOM COMPANY (PRC) PROVIDES BUILDING PAD / FOUNDATION PLAN DRAWINGS FOR PLACEMENT OF OUR BUILDING ON SITE FOUNDATIONS / PADS FOR **REFERENCE ONLY**. PRC DRAWINGS DO NOT INCORPORATE SITE DESIGN FOR LOCAL CODES, SOILS CONDITIONS, FOOTING REQUIREMENTS, AND / OR ANY OTHER CONTRIBUTING SITE FACTORS UP TO AN INCLUDING HIGH WATER TABLES. IT IS THE RESPONSIBILITY OF THE OWNER / GENERAL CONTRACTOR TO PROVIDE A PROPER SITE DESIGN TO ACCOMMODATE THE BUILDING AS WELL AS PROVIDE PROPER SITE CRITERIA SO PRC MAY MODEL SEWER, WATER, AND ELECTRICAL DESIGNS WITHIN THE BUILDING. OUR BUILDING DESIGN INCLUDES AN 8" THICK REINFORCED CONCRETE SLAB AND ASSUMES FULL SLAB BEARING ON SOILS WITH A MINIMUM OF 1500 PSF BEARING CAPACITY. OUR BUILDING DESIGNS SURCHARGE THE SOIL BENEATH THE MAT SLAB AT APPROXIMATE 208 PSF. ANY BUILDING FOUNDATION IN ADDITION TO THE INTEGRAL MAT SLAB ARE SHOWN FOR **REFERENCE ONLY** AND SHOULD BE VERIFIED BY A LICENSED SOILS ENGINEER TO CONFORM WITH REQUIRED CODES.

PRC ASSUMES NO LIABILITY FOR THE OWNER OR GENERAL CONTRACTOR ACCEPTANCE OF THESE TYPICAL DRAWINGS WITHOUT VERIFICATION BY A LICENSED SOILS / FOUNDATION ENGINEER.



COPYRIGHT 2021, PUBLIC RESTROOM COMPANY THIS MATERIAL IS THE EXCLUSIVE PROPERTY OF PUBLIC RESTROOM COMPANY AND SHALL NOT BE REPRODUCED, USED, OR DISCLOSED TO OTHERS EXCEPT AS AUTHORIZED BY THE WRITTEN PERMISSION OF PUBLIC RESTROOM COMPANY.

BUILDING TYPE:

RESTROOM BUILDING

DATE: - DRAWN BY:

PROJECT #: -

PROJECT:

SHEET:

FD-1

1 OF 3

EXAMPLE FOR REFERENCE ONLY

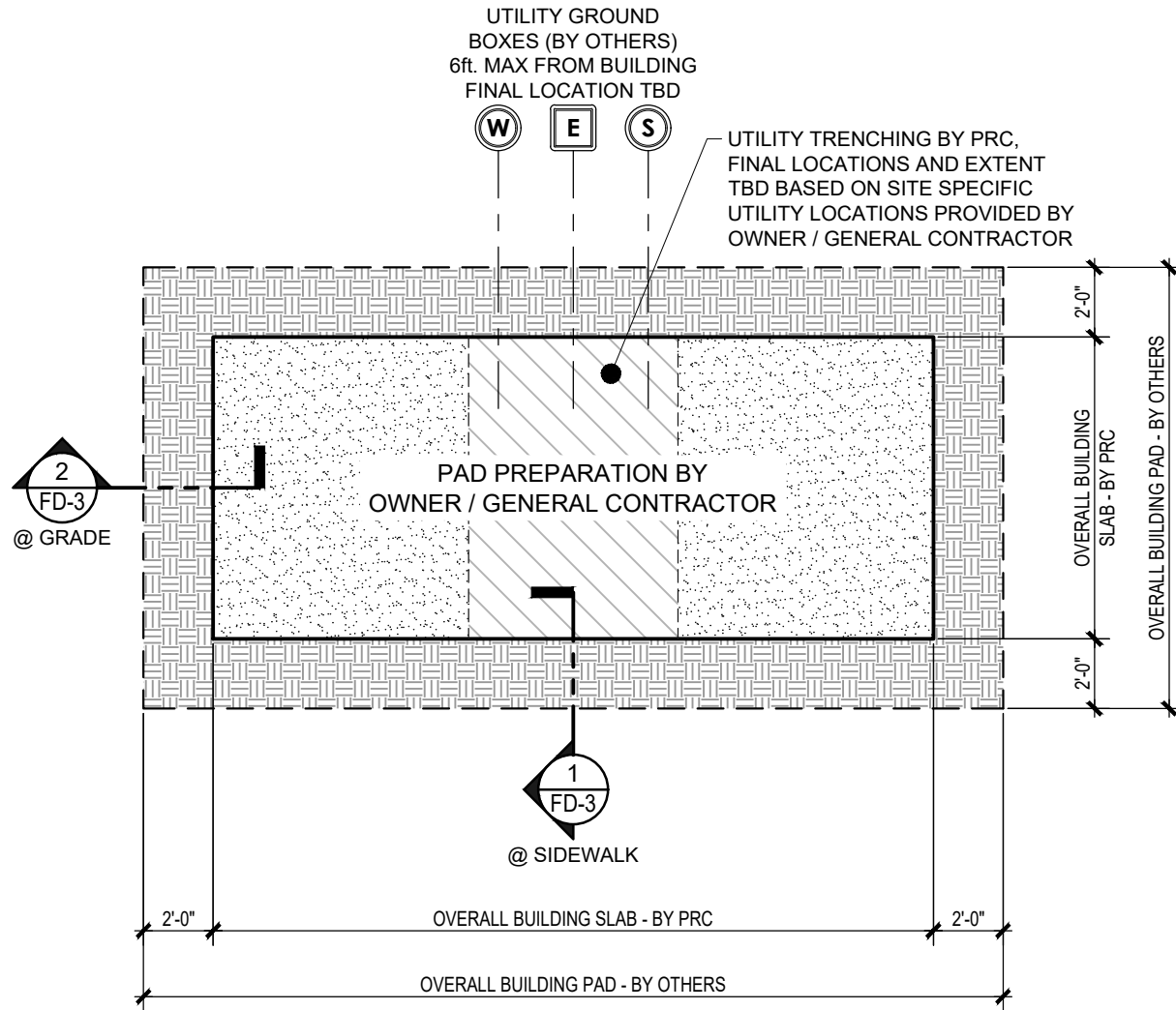

1
FD-2
EXAMPLE PAD PREPARATION PLAN
SCALE: NOT TO SCALE

REQUIRED ALLOWABLE SOIL BEARING PRESSURE = 1500 PSF;
FIELD VERIFIED BY OTHERS



COPYRIGHT 2021, PUBLIC RESTROOM COMPANY THIS MATERIAL IS THE EXCLUSIVE PROPERTY OF PUBLIC RESTROOM COMPANY AND SHALL NOT BE REPRODUCED, USED, OR DISCLOSED TO OTHERS EXCEPT AS AUTHORIZED BY THE WRITTEN PERMISSION OF PUBLIC RESTROOM COMPANY.

BUILDING TYPE:	RESTROOM BUILDING	DATE:	-	DRAWN BY:	-
PROJECT:	-	PROJECT #:	-		
				SHEET:	FD-2
				2 OF 3	

~NOT FOR CONSTRUCTION ~ PRELIMINARY DESIGN DRAWING ONLY ~ DO NOT SCALE, DIMENSIONS PRESIDE

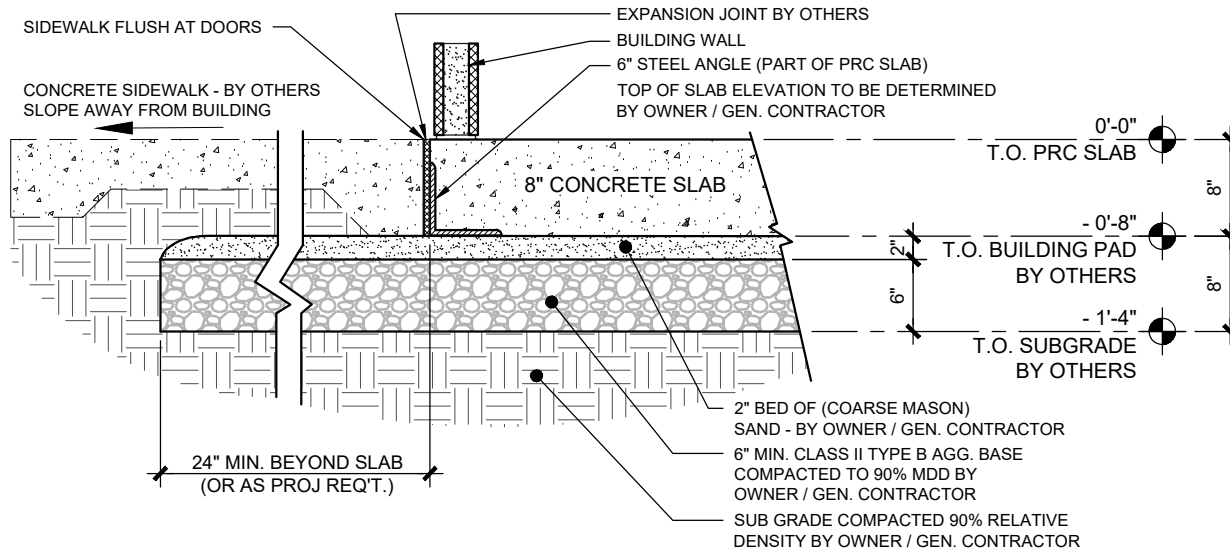

1 SUB-GRADE / PAD SECTION @ SIDEWALK
FD-3 SCALE: NOT TO SCALE

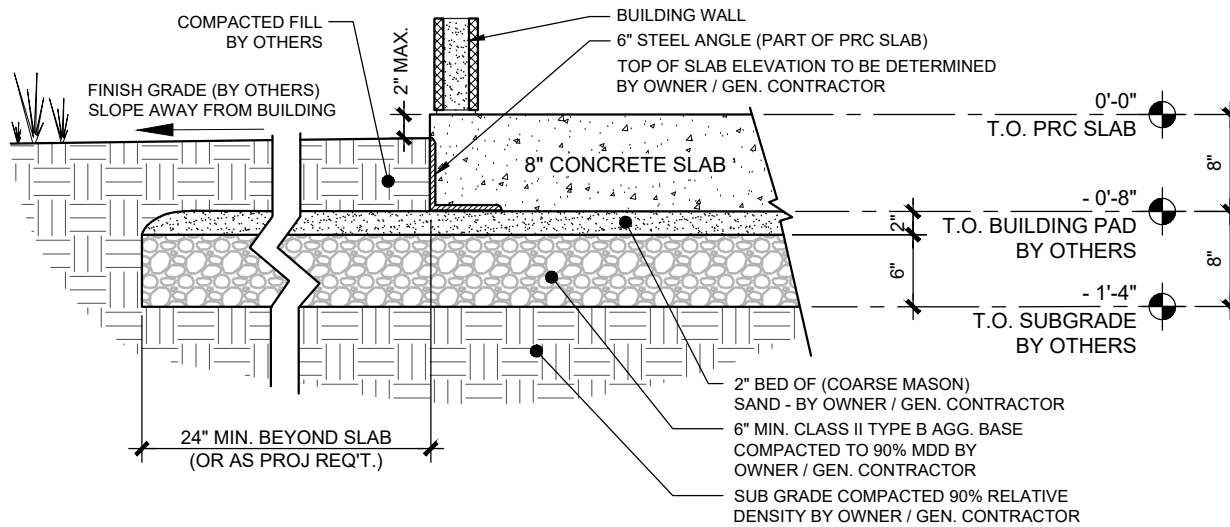

2 SUB-GRADE / PAD SECTION @ GRADE
FD-3 SCALE: NOT TO SCALE



COPYRIGHT 2021, PUBLIC RESTROOM COMPANY THIS MATERIAL IS THE EXCLUSIVE PROPERTY OF PUBLIC RESTROOM COMPANY AND SHALL NOT BE REPRODUCED, USED, OR DISCLOSED TO OTHERS EXCEPT AS AUTHORIZED BY THE WRITTEN PERMISSION OF PUBLIC RESTROOM COMPANY.

BUILDING TYPE: **RESTROOM BUILDING**

PROJECT: -

DATE: - DRAWN BY: -

PROJECT #: -

SHEET: **FD-3**

3 OF 3

SECTION 221116
DOMESTIC WATER PIPING

PART 1 - GENERAL

1.1 SUMMARY

- A. Section includes domestic water piping, valves, fittings, controls and accessories specifications.
- B. Related Sections:
 - 1. Refer to City of Cupertino Project Manual.

1.2 PRICE AND PAYMENT PROCEDURES

- A. Refer to City of Cupertino Project Manual.

1.3 REFERENCES

- A. ASME B16.18 (American Society of Mechanical Engineers) - Cast Copper Alloy Solder Joint Pressure Fittings.
- B. ASME B16.22 (American Society of Mechanical Engineers) - Wrought Copper and Bronze Solder Joint Pressure Fittings.
- C. ASME B16.26 (American Society of Mechanical Engineers) - Cast Bronze Fittings for Flared Copper Tubes.
- D. ASME B31.9 (American Society of Mechanical Engineers) - Service Piping.
- E. ASTM A53 - Pipe, Steel, Black and Hot-Dipped Zinc Coated, Welded and Seamless.
- F. ASTM B32 - Solder Metal.
- G. ASTM B42 - Seamless Copper Pipe.
- H. ASTM D1785 - Poly (Vinyl Chloride) (PVC) Plastic Pipe, Schedules 40, 80, and 120.
- I. ASTM D2855 - Making Solvent-Cemented Joints with Poly (Vinyl Chloride) (PVC) Pipe and Fittings.
- J. ASTM F708 - Design and Installation of Rigid Pipe Hangers.
- K. AWWA C651 (American Water Works Association) - Disinfecting Water Mains.
- L. MSS SP58 (Manufacturers Standardization Society of the Valve and Fittings Industry) - Pipe Hangers and Supports - Materials, Design and Manufacturer.

- M. MSS SP-67 (Manufacturers Standardization Society of the Valve and Fittings Industry) - Butterfly Valves.
- N. MSS SP69 (Manufacturers Standardization Society of the Valve and Fittings Industry) - Pipe Hangers and Supports - Selection and Application.
- O. MSS SP-80 (Manufacturers Standardization Society of the Valve and Fittings Industry) - Bronze Gate, Globe, Angle and Check Valves.
- P. MSS SP89 (Manufacturers Standardization Society of the Valve and Fittings Industry) - Pipe Hangers and Supports - Fabrication and Installation Practices.
- Q. MSS SP-110 (Manufacturers Standardization Society of the Valve and Fittings Industry) - Ball Valves Threaded, Socket-Welding, Solder Joint, Grooved and Flared Ends.
- R. ASME A1126.1 (American Society of Mechanical Engineers) - Water Hammer Arrestors.
- S. ASSE 1011 (American Society of Sanitary Engineering) - Hose Connection Vacuum Breakers.
- T. ASSE 1013 (American Society of Sanitary Engineering) - Backflow Preventers, Reduced Pressure Principle.
- U. AWWA C506 (American Water Works Association) - Backflow Prevention Devices - Reduced Pressure Principle and Double Check Valve Types.
- V. PDI WH-201 (Plumbing and Drainage Institute) - Water Hammer Arrestors.

1.4 SUBMITTALS

- A. Submit restroom design for code, and quality control review. Submit no less than one full set, one half set, and one .pdf soft set.
- B. Cut sheets submittal Procedures: Submit 7 sets for approval.
- C. Product Data:
 - 1. Submit data on pipe materials; pipe fittings, valves, and accessories. Submit manufacturers catalog information. Indicate valve data and ratings.
- D. Manufacturer's Installation Instructions: Submit installation instructions for valves and accessories.
- E. Manufacturer's Certificate: Certify products meet or exceed specified requirements.

1.5 CLOSEOUT SUBMITTALS

- A. Refer to City of Cupertino General Conditions.

1.6 QUALITY ASSURANCE

- A. Perform Work in accordance with:
 - 1. 2010 California Building Code (CBC)
 - 2. 2010 California Plumbing Code (CPC)
- B. Obtain a No-Fee Plumbing Permit from the Department of Public Works. Maintain copy of permit document on site.

1.7 QUALIFICATIONS

- A. Manufacturer: Company specializing in manufacturing products specified in this section with minimum three year's experience.
- B. Installer: Company specializing in performing Work of this section with minimum three year's experience.

1.8 DELIVERY, STORAGE, AND HANDLING

- A. Product Requirements: Product storage and handling requirements.
- B. Accept valves and equipment on site in shipping containers with labeling in place. Inspect for damage.
- C. Provide temporary protective coating on cast iron and steel valves.
- D. Provide temporary end caps and closures on piping and fittings. Maintain in place until installation.
- E. Protect piping systems from entry of foreign materials by temporary covers, completing sections of the work, and isolating parts of completed system.

1.9 FIELD MEASUREMENTS

- A. Verify field measurements prior to fabrication.

1.10 WARRANTY

- A. Final Guarantee: Contractor shall provide guarantee according to City of Cupertino General Conditions.

PART 2 - PRODUCTS

2.1 WATER PIPING, BURIED BEYOND 5 FEET OF DRINKING FOUNTAIN

- A. Copper Tubing: ASTM B88, Type K, hard drawn.

1. Fittings: ASME B16.18, cast copper alloy or ASME B16.22, wrought copper and bronze.
2. Joints: ASTM B32, solder, Grade 95TA.

2.2 WATER PIPING, BURIED WITHIN 5 FEET OF DRINKING FOUNTAIN

- A. Copper Tubing: ASTM B88, Type K, hard drawn.
 1. Fittings: ASME B16.18, cast copper alloy or ASME B16.22, wrought copper and bronze.
 2. Joints: ASTM B32, solder, Grade 95TA.

2.3 WATER PIPING, ABOVE GRADE

- A. Copper Tubing: ASTM B88, Type L, hard drawn.
 1. Fittings: ASME B16.18, cast copper alloy or ASME B16.22, wrought copper and bronze.
 2. Joints: ASTM B32, solder, Grade 95TA.

2.4 FLANGES, UNIONS, AND COUPLINGS

- A. Pipe Size 3 inches and Under:
 1. Copper tube and pipe: Class 150 bronze unions with soldered joints.
- B. Dielectric Connections: Union with galvanized or plated steel threaded end, copper solder end, water impervious isolation barrier.

2.5 GATE VALVES

- A. Up to and including 3 inches:
 1. MSS SP-80, Class 150, bronze body, bronze trim, rising stem, hand
 2. wheel, inside screw, solid wedge disc, solder ends.

PART 3 - EXECUTION

3.1 EXAMINATION

- A. Verify excavations are to required grade, dry, and not over-excavate

3.2 PREPARATION

- A. Ream pipe and tube ends. Remove burrs.
- B. Remove scale and dirt, on inside and outside, before assembly.

3.3 INSTALLATION

- A. Furnish materials in accordance with San Jose Water standards.
- B. Install non-conducting dielectric connections wherever jointing dissimilar metals.
- C. Route piping in orderly manner and maintain gradient. Route parallel and perpendicular to walls.
- D. Install piping to maintain headroom without interfering with use of space or taking more space than necessary.
- E. Group piping whenever practical at common elevations.
- F. Install piping to allow for expansion and contraction without stressing pipe, joints, or connected equipment.
- G. Provide access where valves and fittings are not exposed. Coordinate size and location of access doors with other trades.
- H. Establish elevations of buried piping to obtain not less than 2 ft of cover.
- I. Excavate and backfill in accordance with City of Cupertino Public Work's standards.
- J. Install valves with stems upright or horizontal, not inverted.
- K. Sleeve pipes passing through partitions, walls and floors.
- L. Inserts:
 - 1. Provide inserts for placement in concrete forms.
 - 2. Provide inserts for suspending hangers from reinforced concrete slabs and sides of reinforced concrete beams.
- M. Pipe Hangers and Supports:
 - 1. Install in accordance with ASME B31.9 ASTM F708 and MSS SP89.
 - 2. Support horizontal piping as schedule
 - 3. Install hangers to provide minimum 1/2 inch space between finished covering and adjacent work.
 - 4. Place hangers within 12 inches of each horizontal elbow.
 - 5. Use hangers with 1-1/2 inch minimum vertical adjustment. Design hangers for pipe movement without disengagement of supported pipe.
 - 6. Provide copper plated hangers and supports for copper piping.
 - 7. Prime coat exposed steel hangers and supports.
 - 8. Hangers and supports located in crawl spaces, pipe shafts, and suspended ceiling spaces are not considered exposed.
- N. Install potable water protection devices on plumbing lines where contamination of domestic water may occur; on boiler feed water lines, chiller feed lines, janitor rooms, fire sprinkler systems, premise isolation, irrigation systems, flush valves, interior and exterior hose bibs.
- O. Install water hammer arrestor complete with accessible isolation valve on cold water supply piping to lavatories.

- P. Place pipe tracing conductor with buried non-metallic potable water pipes.

3.4 INTERFACE WITH OTHER PRODUCTS

- A. Install unions downstream of valves and at equipment or apparatus connections.
- B. Install brass male adapters each side of valves in copper piped system. Solder adapters to pipe.
- C. Install valves for shut-off and to isolate equipment, part of systems, vertical risers, and batteries of fixtures.

3.5 ERECTION TOLERANCES

- A. Slope water piping minimum 0.25 percent and arrange to drain at low points.

3.6 CLEANING

- A. Disinfecting of Domestic Water
- B. Prior to starting work, verify system is complete, flushed and clean.
- C. Verify pH of water to be treated is between 7.4 and 7.6 by adding alkali (caustic soda or soda ash) or acid (hydrochloric).
- D. Inject disinfectant, free chlorine in liquid, powder and tablet or gas form, throughout system to obtain residual from 50 to 80 mg/L.
- E. Bleed water from outlets to obtain distribution and test for disinfectant residual at minimum 15 percent of outlets.
- F. Maintain disinfectant in system for 24 hours.
- G. When final disinfectant residual tests less than 25 mg/L, repeat treatment.
- H. Flush disinfectant from system until residual concentration is equal to incoming water or 1.0 mg/L.
- I. Take samples no sooner than 24 hours after flushing, from 2 outlets and from water entry, and analyze in accordance with AWWA C651.
- J. Provide disinfection report

END OF SECTION

**SECTION 26 05 00
GENERAL REQUIREMENTS FOR ELECTRICAL SYSTEMS**

PART 1 GENERAL**1.01 DESCRIPTION OF WORK:**

- A. The work of this Section consists of providing all required labor, supervision, materials and equipment (except equipment furnished by the Owner to be installed by the Contractor) to satisfactorily complete the work shown on the drawings and/or specified in all Sections of Division 26 and all other work and miscellaneous items, not specifically mentioned, but reasonably inferred for a complete and fully operating facility. The work shall include but not be limited to the following:
1. Furnish and install all required in-place equipment, conduits, conductors, cables and any miscellaneous materials for the satisfactory interconnection and operation of all associated electrical systems.

1.02 RELATED WORK:

- A. This Section provides the basic Electrical Requirements which supplement the City of Cupertino Project Manual and apply to all Sections of Division 26.

1.03 STANDARDS AND CODES:

- A. All work and material shall be in compliance with and according to the requirements of the latest revision of the following standards and codes:
1. 2022 California Electrical Code (CEC)
 2. National Fire Protection Association (NFPA):
 - a. 70 National Electrical Code (NEC) / 2022 California Electrical Code (CEC)
 3. American National Standards Institute (ANSI) Publications:
 - a. C2-02 National Electrical Safety Code
 4. Code of Federal Regulations (CFR):
 - a. 29 CFR 1910.147 Control of Hazardous Energy (Lock Out/Tag Out)
 5. Electronics Industries Association / Telecommunications Industries Association (EIA / TIA)
 6. Institute of Electrical and Electronics Engineers (IEEE)
 7. National Electrical Testing Association (NETA):
 - a. Acceptance Testing Specifications for Electrical Power Distribution Equipment and Systems, Standard ATS
 8. National Electrical Manufacturers Association (NEMA)
 9. Occupational Safety and Health Act (OSHA) Standards
 10. State of California Public Utilities Commission:
 - a. General Order 128 Rules for Construction of Underground Electric Supply and Communication Systems
 11. Variances: In instances where two or more codes are at variance, the most restrictive requirement shall apply.
 12. Underwriter Laboratories (UL) listing is required for all equipment and materials where such listing is offered by the Underwriters Laboratories. Safety labeling and listing by other organizations, such as ETL Testing Laboratories, may be substituted for UL labeling and listing if acceptable to the Owner. Provide service entrance labels for all equipment required by the NEC to have such labels.

1.04 SUBMITTALS:

- A. Refer to City of Cupertino Project Manual. Submit to the Engineer shop drawings, manufacturer's data and certificates for equipment, materials and finish, and pertinent details for each system specified. Obtain approval before procurement, fabrication, or delivery of the items to the job site. Partial submittals are not acceptable and will be returned without review.

1.05 CONTRACT DOCUMENTS:

- A. Contractor shall review the Drawings and Specification Divisions of other trades and perform the electrical work that will be required for the installations.

1. Should there be a need to deviate from the Electrical Drawings and Specifications, submit written details and reasons for all changes to the Engineer for favorable review.
 2. All drawings and divisions of these specifications shall be considered as whole. This Contractor shall report any apparent discrepancies prior to submitting bids.
 3. Should there be a conflict or discrepancy between the drawings and specifications, or between different drawings sheets, or between different specification sections, the most expensive option shall be required, at the discretion of the Engineer.
- B. Drawings:
1. The Drawings shall govern the general layout of the completed construction:
 - a. Locations of equipment, inserts, anchors, panels, pullboxes, manholes, conduits, stub-ups, fittings, power and convenience outlets, lighting fixtures and ground connections are approximate unless dimensioned; verify locations with the Engineer prior to installation. Field verify scaled dimensions on Drawings.
 - b. The general arrangement and location of existing conduits, piping, apparatus, etc., is shown as existing on drawings or specified. The drawings and specifications are for the assistance and guidance of the Contractor, exact locations, distances and elevations are governed by actual field conditions. Extreme accuracy of data given herein and on the drawings is not guaranteed. Minor changes may be necessary to accommodate work. The Contractor is responsible for verifying existing conditions. Should it be necessary to deviate from the design due to interference with existing conditions or work in progress, claims for additional compensation shall be limited to those for work required by unforeseen conditions as determined by the Engineer.

1.06 COORDINATION:

- A. Coordinate the electrical work with the other trades, code authorities, utilities and the Engineer:
1. Failure to accomplish this coordination is not a basis for additional cost reimbursement to the Contractor.
 2. Coordinate does not mean to only send a Request For Information. Coordinate implies that the Contractor is to take the lead in bringing all of the necessary organizations together to coordinate the work and to provide for the associated costs.
- B. Where connections must be made to existing installations, properly schedule all the required work, including the power shutdown periods. Schedule and carry out shutdowns so as to cause the least disruption to operation of the Owner's facilities:
1. Include costs for work during non-normal working hours and temporary facilities as may be required.
 2. Include costs as necessary for sub-Contractors as necessary to accomplish the specified work.
- C. When two trades join together in an area, make certain that no electrical work is omitted. Failure to accomplish this coordination is not a basis for additional cost reimbursement to the Contractor.
- D. Operations:
1. Perform all work in compliance with City of Cupertino Project Manual:
 - a. Keep the number and duration of power shutdown periods to a minimum.
 - b. Where shutdowns are required, coordinate time and duration with Owner and Utility representatives a minimum of 2 weeks in advance.
 - c. All shutdowns which would interfere with the operations of Owner's equipment or facilities shall be coordinated with the Owner a minimum of 15 days in advance.
 - 1) Where Owner's equipment or facilities must remain operational during the shutdown, provide sufficient means to temporarily backup the interrupted services for the duration of the interruption.
 - d. Show all proposed shutdowns and their expected duration on the construction schedule.
 - 1) If the construction schedule is created and maintained by others, make sure that the associated information is incorporated.

- 2) Failure by the Contractor to properly schedule and plan for such activities is not a basis for additional compensation.
 - e. Carry out shutdown only after the Engineer has favorably reviewed the schedule. Submit power/communications interruption schedule 15 days prior to date of interruption. Failure to provide schedule with adequate review time may result in rescheduling of the work at the Contractor's expense.
- E. Construction Power:
1. See Division 1 Temporary Utilities.
- F. Storage:
1. Provide adequate storage for all equipment and materials which will become part of the completed facility so that it is protected from sun, weather, condensation, dust, water, or construction operations.
- G. Damaged Products:
1. Notify the Engineer in writing in the event that any equipment or material is damaged. Obtain approval from the Engineer and Manufacturer before making repairs to damaged products.
- H. Order material in such a timely manner and after approval of the same so as to ensure that the approved material is available to be installed on site in a timely manner. Additional costs or substitutions necessitated because the Contractor failed to order material in a timely manner are not reimbursable. Costs associated with processing of paperwork by the Owner and design consultants resultant of such failures to coordinate the work by the Contractor shall have such costs reimbursed by the Contractor.

1.07 LOCATIONS:

- A. General: Use equipment, materials and wiring methods suitable for the types of locations in which they are located.
1. Dry Locations:
 - a. All those indoor areas which do not fall within the definition below for Wet Locations and which are not otherwise designated on the Drawings.
 2. Wet Locations:
 - a. All locations exposed to the weather or contact with water (such as kitchen areas subject to directional water spray as a means of cleaning surfaces), whether under a roof or not, unless otherwise designated on the Drawings.

1.08 SAFETY AND INDEMNITY:

- A. Lock out Requirements:
1. Provide disconnecting means capable of being locked out for machines and other equipment to prevent unexpected startup or release of stored energy in accordance with 29 CFR 1910.147
- B. The Contractor is solely and completely responsible for conditions of the job site including safety of all persons and properly during performance of the work. This requirement will apply continually and not be limited to normal working hours.
1. No act, service, drawing review or construction review by the Owner, the Engineer or their Consultants is intended to include reviews of the adequacy of the Contractors safety measures in or near the construction site.

PART 2 PRODUCTS

2.01 STANDARD OF QUALITY:

- A. Material and Equipment: Provide materials and equipment that are new and are current products of manufacturers regularly engaged in the production of such products. The standard products shall have been in satisfactory commercial or industrial use for two years prior to bid opening. The two-year period includes use of equipment and materials of similar size under similar circumstances. For uniformity, only one manufacturer will be accepted for each type of product.

- B. Service Support: Submit a certified list of qualified permanent service organizations including their addresses and qualification for support of the equipment. These service organizations shall be convenient to the equipment installation and able to render service to the equipment on a regular and emergency basis during the warranty period of the contract.
- C. Manufacturer's Recommendations: Where installation procedures are required to be in accordance with manufacturer's recommendations, furnish printed copies of the recommendations prior to installation. Installation of the item shall not proceed until recommendations are received. Failure to furnish recommendation shall be cause for rejection of the equipment or material.

2.02 FASTENERS:

- A. Fasteners for securing equipment to walls, floors and the like shall be either hot-dip galvanized after fabrication or stainless steel.

2.03 FINISH REQUIREMENTS:

- A. Equipment: Refer to each electrical equipment section of these Specifications for painting requirements of equipment enclosures. Repair any final paint finish which has been damaged or is otherwise unsatisfactory, to the satisfaction of the Engineer.
- B. In finished areas, paint all exposed conduits, boxes and fittings to match the color of the surface to which they are affixed.

PART 3 EXECUTION

3.01 INSTALLATION:

- A. Ensure that all equipment and materials fit properly in their installation.
- B. Perform any required work to correct improperly fit installation at no additional expense to the Owner.
- C. Equipment Installation:
 - 1. Provide the required inserts, bolts and anchors, and securely attach all equipment and materials to their supports.
 - 2. In all rooms with concrete floors, install all floor mounted equipment on reinforced concrete pads as shown. Insure that pads are seismically secured to the building structure. The Contractor, suppliers, and fabricators shall take this requirement into consideration when designing, fabricating, and installing panels and other enclosures so that height above the floor of the operating handles of electrical devices meets the requirements of these Specifications and applicable codes.
 - 3. Mount all metal panels which are mounted on or abutting concrete walls or any outside walls a minimum of ¼ inch from the wall, and paint the back sides of the panels with Bituminous Coating, Rust-oleum C9578 Coal Tar Epoxy Coating or approved equal. Film thickness shall be 10 mils minimum.
- D. Cutting, Drilling and Welding:
 - 1. Provide the required cutting, drilling welding that is required for the electrical construction work. Comply with Division 1 requirements.
 - 2. Structural members shall not be cut or drilled, except after approval by the Engineer. Use a core drill wherever it is necessary to drill through concrete or masonry.
 - 3. Provide the required welding for equipment supports. Conduits and fittings shall not be welded to structural steel. Where welding is required, it shall be accomplished by tradesmen certified to do such work. Provide fire and other protection as appropriate.

3.02 FIELD TESTS:

- A. Test shall be in accordance with Acceptance Testing specifications issued by the National Electrical Testing Association (NETA).
- B. Perform equipment field tests and adjustments. Properly calibrate, adjust and operationally check all circuits and components, and demonstrate as ready for service. Perform each operational check three times to ensure the circuit and components are working properly. Make additional calibration and adjustments if it is determined later that the initial adjustments

are not satisfactory for proper performance. Perform equipment field test for equipment where equipment field tests are specified in the equipment Specifications. Give sufficient notice to the Engineer prior to any test so that the tests may be witnessed.

- C. Provide instruments, other equipment, temporary facilities as may be necessary, and material required for the tests. These shall be of the type designed for the type of tests to be performed and shall be calibrated by a recognized testing laboratory within three months prior to testing.
- D. Operational Tests: Operationally test all circuits to demonstrate that the circuits and equipment have been properly installed and adjusted and are ready for full-time service. Demonstrate the proper functioning of circuits in all modes of operation, including alarm conditions.
- E. Re-testing will be required for all unsatisfactory tests after the equipment or system has been repaired. Re-test all related equipment and systems if required by the Engineer. Repair and re-test equipment and systems which have been satisfactorily tested but later fail, until satisfactory performance is obtained.
- F. Perform calibration and adjustment on all equipment. Where the values for adjustment are not shown on the Drawings, obtain the proper values from the Engineer.
- G. Maintain records of each test and submit five copies to the Engineer when testing is complete. All tests shall be witnessed by the Owner and/or Engineer at their discretion. These records shall include:
 - 1. Name of equipment tested.
 - 2. Date of report.
 - 3. Date of test.
 - 4. Description of test setup.
 - 5. Identification and rating of test equipment.
 - 6. Test results and data.
 - 7. Name of person performing test.
 - 8. Owner or Engineer's initials.
- H. Items requiring testing as a minimum:
 - 1. Ground field grid.
 - 2. Circuit Breakers.

3.03 PAINTING OF EQUIPMENT:

- A. Factory Applied: Electrical equipment shall have factory applied painting system which shall, as a minimum, meet the requirements of NEMA ICS 6 corrosion-resistance test and the additional requirements specified in the technical section.
- B. Field Applied: Paint electrical equipment as required to match finish of adjacent surfaces or to meet the indicated or specified safety criteria.

3.04 RECORDS:

- A. Maintain one copy of the contract Drawing Sheets on the site of the work for recording the record "as built" condition. After completion of the work, the Contractor shall neatly and carefully mark the work as actually constructed, revising, deleting and adding to the Drawing Sheets as required. The following requirements shall be complied with:
 - 1. Drawings and associated as-built changes shall be completed in AutoCAD or Revit and submitted in CAD/Revit as well as PDF format. Documents with hand-written changes or with RFI responses and field sketches pasted on shall not be acceptable. Engineer shall make digital backgrounds of original contract documents available for Contractor's use upon request.
 - 2. Cable Size and Type: Provide the size and type of each cable installed on the project.
 - 3. Substructure: Where the location of duct lines, adjacent utilities, cable boxes, and manholes are found to be different than shown, carefully mark the correct location on the Drawings. Work shall be dimensioned from existing improvements.
 - 4. Record (As Built) Drawings: At the completion of the Work the Contractor shall provide a set of record "as built" drawings over to the Owner for their use.

3.05 CLEAN UP:

- A. Thoroughly clean all soiled surfaces of installed equipment and materials, including, but not limited to, removal of all dirt, dust, debris, and unused construction materials.
- B. Upon completion of electrical work, remove all surplus materials, rubbish, and debris that accumulated during the construction work. Leave the entire area neat, clean, and acceptable to the Engineer.

END OF SECTION

SECTION 26 05 19
LOW-VOLTAGE ELECTRICAL POWER CONDUCTORS AND CABLES

PART 1 GENERAL**1.01 SECTION INCLUDES**

- A. Single conductor building wire.
- B. Underground feeder and branch-circuit cable.
- C. Service entrance cable.
- D. Wiring connectors.
- E. Electrical tape.
- F. Heat shrink tubing.
- G. Oxide inhibiting compound.
- H. Wire pulling lubricant.
- I. Cable ties.
- J. Firestop sleeves.

1.02 RELATED REQUIREMENTS

- A. Section 26 05 26 - Grounding and Bonding for Electrical Systems: Additional requirements for grounding conductors and grounding connectors.

1.03 REFERENCE STANDARDS

- A. ASTM B3 - Standard Specification for Soft or Annealed Copper Wire; 2013 (Reapproved 2018).
- B. ASTM B8 - Standard Specification for Concentric-Lay-Stranded Copper Conductors, Hard, Medium-Hard, or Soft; 2011 (Reapproved 2017).
- C. ASTM B33 - Standard Specification for Tin-Coated Soft or Annealed Copper Wire for Electrical Purposes; 2010, with Editorial Revision (2020).
- D. ASTM B787/B787M - Standard Specification for 19 Wire Combination Unilay-Stranded Copper Conductors for Subsequent Insulation; 2004 (Reapproved 2020).
- E. ASTM D3005 - Standard Specification for Low-Temperature Resistant Vinyl Chloride Plastic Pressure-Sensitive Electrical Insulating Tape; 2017.
- F. ASTM D4388 - Standard Specification for Nonmetallic Semi-Conducting and Electrically Insulating Rubber Tapes; 2020.
- G. NECA 1 - Standard for Good Workmanship in Electrical Construction; 2015.
- H. NECA 121 - Standard for Installing Nonmetallic-Sheathed Cable (Type NM-B) and Underground Feeder and Branch-Circuit Cable (Type UF); 2007.
- I. NEMA WC 70 - Power Cables Rated 2000 Volts or Less for the Distribution of Electrical Energy; 2021.
- J. NETA ATS - Standard For Acceptance Testing Specifications For Electrical Power Equipment And Systems; 2021.
- K. NFPA 70 - National Electrical Code; Most Recent Edition Adopted by Authority Having Jurisdiction, Including All Applicable Amendments and Supplements.
- L. UL 44 - Thermoset-Insulated Wires and Cables; Current Edition, Including All Revisions.
- M. UL 83 - Thermoplastic-Insulated Wires and Cables; Current Edition, Including All Revisions.
- N. UL 267 - Outline of Investigation for Wire-Pulling Compounds; Most Recent Edition, Including All Revisions.
- O. UL 486A-486B - Wire Connectors; Current Edition, Including All Revisions.
- P. UL 486C - Splicing Wire Connectors; Current Edition, Including All Revisions.
- Q. UL 486D - Sealed Wire Connector Systems; Current Edition, Including All Revisions.

- R. UL 493 - Thermoplastic-Insulated Underground Feeder and Branch-Circuit Cables; Current Edition, Including All Revisions.
- S. UL 510 - Polyvinyl Chloride, Polyethylene, and Rubber Insulating Tape; Current Edition, Including All Revisions.
- T. UL 854 - Service-Entrance Cables; Current Edition, Including All Revisions.

1.04 ADMINISTRATIVE REQUIREMENTS

- A. Coordination:
 - 1. Coordinate sizes of raceways, boxes, and equipment enclosures installed under other sections with the actual conductors to be installed, including adjustments for conductor sizes increased for voltage drop.
 - 2. Coordinate with electrical equipment installed under other sections to provide terminations suitable for use with the conductors to be installed.
 - 3. Notify Architect of any conflicts with or deviations from Contract Documents. Obtain direction before proceeding with work.

1.05 SUBMITTALS

- A. Product Data: Provide manufacturer's standard catalog pages and data sheets for conductors and cables, including detailed information on materials, construction, ratings, listings, and available sizes, configurations, and stranding.
- B. Manufacturer's Installation Instructions: Indicate application conditions and limitations of use stipulated by product testing agency. Include instructions for storage, handling, protection, examination, preparation, and installation of product.
- C. Project Record Documents: Record actual installed circuiting arrangements. Record actual routing for underground circuits.

1.06 QUALITY ASSURANCE

- A. Comply with requirements of NFPA 70.
- B. Manufacturer Qualifications: Company specializing in manufacturing the products specified in this section with minimum three years documented experience.
- C. Product Listing Organization Qualifications: An organization recognized by OSHA as a Nationally Recognized Testing Laboratory (NRTL) and acceptable to authorities having jurisdiction.

1.07 DELIVERY, STORAGE, AND HANDLING

- A. Receive, inspect, handle, and store conductors and cables in accordance with manufacturer's instructions.

1.08 FIELD CONDITIONS

- A. Do not install or otherwise handle thermoplastic-insulated conductors at temperatures lower than 14 degrees F, unless otherwise permitted by manufacturer's instructions. When installation below this temperature is unavoidable, notify Architect and obtain direction before proceeding with work.

PART 2 PRODUCTS

2.01 CONDUCTOR AND CABLE APPLICATIONS

- A. Do not use conductors and cables for applications other than as permitted by NFPA 70 and product listing.
- B. Provide single conductor building wire installed in suitable raceway unless otherwise indicated, permitted, or required.
- C. Nonmetallic-sheathed cable is not permitted.
- D. Armored cable is not permitted.
- E. Metal-clad cable is not permitted.

2.02 CONDUCTOR AND CABLE GENERAL REQUIREMENTS

- A. Provide products that comply with requirements of NFPA 70.
- B. Provide products listed, classified, and labeled as suitable for the purpose intended.
- C. Unless specifically indicated to be excluded, provide all required conduit, boxes, wiring, connectors, etc. as required for a complete operating system.
- D. Comply with NEMA WC 70.
- E. Thermoplastic-Insulated Conductors and Cables: Listed and labeled as complying with UL 83.
- F. Thermoset-Insulated Conductors and Cables: Listed and labeled as complying with UL 44.
- G. Conductors for Grounding and Bonding: Also comply with Section 26 05 26.
- H. Conductor Material:
 - 1. Provide copper conductors only. Aluminum conductors are not acceptable for this project. Conductor sizes indicated are based on copper.
 - 2. Copper Conductors: Soft drawn annealed, 98 percent conductivity, uncoated copper conductors complying with ASTM B3, ASTM B8, or ASTM B787/B787M unless otherwise indicated.
 - 3. Tinned Copper Conductors: Comply with ASTM B33.
- I. Minimum Conductor Size:
 - 1. Branch Circuits: 12 AWG.
 - a. Exceptions:
 - 1) 20 A, 120 V circuits longer than 75 feet: 10 AWG, for voltage drop.
 - 2) 20 A, 120 V circuits longer than 150 feet: 8 AWG, for voltage drop.
 - 3) 20 A, 277 V circuits longer than 150 feet: 10 AWG, for voltage drop.
 - 2. Control Circuits: 14 AWG.
- J. Where conductor size is not indicated, size to comply with NFPA 70 but not less than applicable minimum size requirements specified.
- K. Conductor Color Coding:
 - 1. Color code conductors as indicated unless otherwise required by the authority having jurisdiction. Maintain consistent color coding throughout project.
 - 2. Color Coding Method: Integrally colored insulation.
 - a. Conductors size 4 AWG and larger may have black insulation color coded using vinyl color coding electrical tape.
 - 3. Color Code:
 - a. 208Y/120 V, 3 Phase, 4 Wire System:
 - 1) Phase A: Black.
 - 2) Phase B: Red.
 - 3) Phase C: Blue.
 - 4) Neutral/Grounded: White.
 - b. Equipment Ground, All Systems: Green.
 - c. For control circuits, comply with manufacturer's recommended color code.

2.03 SINGLE CONDUCTOR BUILDING WIRE

- A. Manufacturers:
 - 1. Copper Building Wire:
 - a. Cerro Wire LLC: www.cerrowire.com/#sle.
 - b. General Cable Technologies Corporation: www.generalcable.com/#sle.
 - c. Southwire Company: www.southwire.com/#sle.
- B. Description: Single conductor insulated wire.
- C. Conductor Stranding:
 - 1. Feeders and Branch Circuits:
 - a. Size 10 AWG and Smaller: Solid.

- b. Size 8 AWG and Larger: Stranded.
- D. Insulation Voltage Rating: 600 V.
- E. Insulation:
 - 1. Copper Building Wire: Type THHN/THWN or THHN/THWN-2, except as indicated below.
 - a. Size 6 AWG and Larger: Type XHHW-2.
 - b. Installed Underground: Type XHHW-2.
 - c. Fixture Wiring Within Luminaires: Type TFFN/TFN for luminaires with labeled maximum temperature of 90 degrees C; Approved suitable type for luminaires with labeled maximum temperature greater than 90 degrees C.

2.04 UNDERGROUND FEEDER AND BRANCH-CIRCUIT CABLE

- A. Manufacturers:
 - 1. Southwire Company: www.southwire.com/#sle.
- B. Description: NFPA 70, Type UF multiple-conductor cable listed and labeled as complying with UL 493, Type UF-B.
- C. Provide equipment grounding conductor unless otherwise indicated.
- D. Conductor Stranding:
 - 1. Size 10 AWG and Smaller: Solid.
 - 2. Size 8 AWG and Larger: Stranded.
- E. Insulation Voltage Rating: 600 V.

2.05 SERVICE ENTRANCE CABLE

- A. Manufacturers:
 - 1. Copper Service Entrance Cable:
 - a. Cerro Wire LLC: www.cerrowire.com/#sle.
 - b. Encore Wire Corporation: www.encorewire.com/#sle.
 - c. Southwire Company: www.southwire.com/#sle.
- B. Service Entrance Cable for Above-Ground Use: NFPA 70, Type SE multiple-conductor cable listed and labeled as complying with UL 854, Style R.
- C. Service Entrance Cable for Underground Use: NFPA 70, Type USE single-conductor cable listed and labeled as complying with UL 854, Type USE-2, and with UL 44 Type RHH/RHW-2.
- D. Conductor Stranding: Stranded.
- E. Insulation Voltage Rating: 600 V.

2.06 WIRING CONNECTORS

- A. Description: Wiring connectors appropriate for the application, suitable for use with the conductors to be connected, and listed as complying with UL 486A-486B or UL 486C as applicable.
- B. Connectors for Grounding and Bonding: Comply with Section 26 05 26.
- C. Wiring Connectors for Splices and Taps:
 - 1. Copper Conductors Size 8 AWG and Smaller: Use twist-on insulated spring connectors.
 - 2. Copper Conductors Size 6 AWG and Larger: Use mechanical connectors.
- D. Wiring Connectors for Terminations:
 - 1. Provide terminal lugs for connecting conductors to equipment furnished with terminations designed for terminal lugs.
 - 2. Where over-sized conductors are larger than the equipment terminations can accommodate, provide connectors suitable for reducing to appropriate size, but not less than required for the rating of the overcurrent protective device.
 - 3. Provide motor pigtail connectors for connecting motor leads in order to facilitate disconnection.
 - 4. Copper Conductors Size 8 AWG and Larger: Use mechanical connectors where connectors are required.

5. Stranded Conductors Size 10 AWG and Smaller: Use crimped terminals for connections to terminal screws.
6. Conductors for Control Circuits: Use crimped terminals for all connections.
- E. Do not use insulation-piercing or insulation-displacement connectors designed for use with conductors without stripping insulation.
- F. Do not use push-in wire connectors as a substitute for twist-on insulated spring connectors.
- G. Twist-on Insulated Spring Connectors: Rated 600 V, 221 degrees F for standard applications and 302 degrees F for high temperature applications; pre-filled with sealant and listed as complying with UL 486D for damp and wet locations.
 1. Manufacturers:
 - a. 3M: www.3m.com/#sle.
 - b. Ideal Industries, Inc: www.idealindustries.com/#sle.
 - c. NSI Industries LLC: www.nsiindustries.com/#sle.
- H. Mechanical Connectors: Provide bolted type or set-screw type.
 1. Manufacturers:
 - a. Burndy LLC: www.burndy.com/#sle.
 - b. IlSCO: www.ilSCO.com/#sle.
 - c. Thomas & Betts Corporation: www.tnb.com/#sle.
- I. Crimped Terminals: Nylon-insulated, with insulation grip and terminal configuration suitable for connection to be made.
 1. Manufacturers:
 - a. Burndy LLC: www.burndy.com/#sle.
 - b. IlSCO: www.ilSCO.com/#sle.
 - c. Thomas & Betts Corporation: www.tnb.com/#sle.

2.07 ACCESSORIES

- A. Electrical Tape:
 1. Manufacturers:
 - a. 3M: www.3m.com/#sle.
 2. Vinyl Color Coding Electrical Tape: Integrally colored to match color code indicated; listed as complying with UL 510; minimum thickness of 7 mil; resistant to abrasion, corrosion, and sunlight; suitable for continuous temperature environment up to 221 degrees F.
 3. Vinyl Insulating Electrical Tape: Complying with ASTM D3005 and listed as complying with UL 510; minimum thickness of 7 mil; resistant to abrasion, corrosion, and sunlight; conformable for application down to 0 degrees F and suitable for continuous temperature environment up to 221 degrees F.
 4. Rubber Splicing Electrical Tape: Ethylene Propylene Rubber (EPR) tape, complying with ASTM D4388; minimum thickness of 30 mil; suitable for continuous temperature environment up to 194 degrees F and short-term 266 degrees F overload service.
 5. Electrical Filler Tape: Rubber-based insulating moldable putty, minimum thickness of 125 mil; suitable for continuous temperature environment up to 176 degrees F.
 6. Moisture Sealing Electrical Tape: Insulating mastic compound laminated to flexible, all-weather vinyl backing; minimum thickness of 90 mil.
- B. Heat Shrink Tubing: Heavy-wall, split-resistant, with factory-applied adhesive; rated 600 V; suitable for direct burial applications; listed as complying with UL 486D.
 1. Manufacturers:
 - a. 3M: www.3m.com/#sle.
 - b. Burndy LLC: www.burndy.com/#sle.
 - c. Thomas & Betts Corporation: www.tnb.com/#sle.
- C. Oxide Inhibiting Compound: Listed; suitable for use with the conductors or cables to be installed.
 1. Manufacturers:
 - a. Burndy LLC: www.burndy.com/#sle.

- b. Ideal Industries, Inc: www.idealindustries.com/#sle.
- c. IlSCO: www.ilSCO.com/#sle.
- D. Wire Pulling Lubricant:
 - 1. Manufacturers:
 - a. 3M: www.3m.com/#sle.
 - b. American Polywater Corporation: www.polywater.com/#sle.
 - c. Ideal Industries, Inc: www.idealindustries.com/#sle.
 - 2. Listed and labeled as complying with UL 267.
 - 3. Suitable for use with conductors/cables and associated insulation/jackets to be installed.
 - 4. Suitable for use at installation temperature.
- E. Cable Ties: Material and tensile strength rating suitable for application.
 - 1. Manufacturers:
 - a. Burndy LLC: www.burndy.com/#sle.
- F. Sealing Systems for Roof Penetrations: Premanufactured components and accessories as required to preserve integrity of roofing system and maintain roof warranty; suitable for cables and roofing system to be installed; designed to accommodate existing penetrations where applicable.
 - 1. Products:
 - a. Menzies Metal Products; Electrical Roof Stack and Cap: www.menzies-metal.com/#sle.
 - b. Menzies Metal Products; Electrical Retro Box: www.menzies-metal.com/#sle.
- G. Firestop Sleeves: Listed; provide as required to preserve fire resistance rating of building elements.
 - 1. Products:
 - a. HoldRite, a brand of Reliance Worldwide Corporation; HydroFlame Pro Series/HydroFlame Custom Built: www.holdrite.com/#sle.

PART 3 EXECUTION

3.01 EXAMINATION

- A. Verify that interior of building has been protected from weather.
- B. Verify that work likely to damage wire and cable has been completed.
- C. Verify that raceways, boxes, and equipment enclosures are installed and are properly sized to accommodate conductors and cables in accordance with NFPA 70.
- D. Verify that field measurements are as indicated.
- E. Verify that conditions are satisfactory for installation prior to starting work.

3.02 PREPARATION

- A. Clean raceways thoroughly to remove foreign materials before installing conductors and cables.

3.03 INSTALLATION

- A. Circuiting Requirements:
 - 1. Unless dimensioned, circuit routing indicated is diagrammatic.
 - 2. When circuit destination is indicated without specific routing, determine exact routing required.
 - 3. Maintain separation of Class 1, Class 2, and Class 3 remote-control, signaling, and power-limited circuits in accordance with NFPA 70.
 - 4. Maintain separation of wiring for emergency systems in accordance with NFPA 70.
 - 5. Circuiting Adjustments: Unless otherwise indicated, when branch circuits are indicated as separate, combining them together in a single raceway is not permitted.
 - 6. Common Neutrals: Unless otherwise indicated, sharing of neutral/grounded conductors among up to three single phase branch circuits of different phases installed in the same raceway is not permitted. Provide dedicated neutral/grounded conductor for each

individual branch circuit.

- B. Install products in accordance with manufacturer's instructions.
- C. Perform work in accordance with NECA 1 (general workmanship).
- D. Install underground feeder and branch-circuit cable (Type UF-B) in accordance with NECA 121.
- E. Installation in Raceway:
 - 1. Tape ends of conductors and cables to prevent infiltration of moisture and other contaminants.
 - 2. Pull all conductors and cables together into raceway at same time.
 - 3. Do not damage conductors and cables or exceed manufacturer's recommended maximum pulling tension and sidewall pressure.
 - 4. Use suitable wire pulling lubricant where necessary, except when lubricant is not recommended by the manufacturer.
- F. Exposed Cable Installation (only where specifically permitted):
 - 1. Route cables parallel or perpendicular to building structural members and surfaces.
 - 2. Protect cables from physical damage.
- G. Paralleled Conductors: Install conductors of the same length and terminate in the same manner.
- H. Secure and support conductors and cables in accordance with NFPA 70 using suitable supports and methods approved by the authority having jurisdiction. Provide independent support from building structure. Do not provide support from raceways, piping, ductwork, or other systems.
 - 1. Installation Above Suspended Ceilings: Do not provide support from ceiling support system. Do not provide support from ceiling grid or allow conductors and cables to lay on ceiling tiles.
 - 2. Installation in Vertical Raceways: Provide supports where vertical rise exceeds permissible limits.
- I. Terminate cables using suitable fittings.
- J. Install conductors with a minimum of 12 inches of slack at each outlet.
- K. Neatly train and bundle conductors inside boxes, wireways, panelboards and other equipment enclosures.
- L. Group or otherwise identify neutral/grounded conductors with associated ungrounded conductors inside enclosures in accordance with NFPA 70.
- M. Make wiring connections using specified wiring connectors.
 - 1. Make splices and taps only in accessible boxes. Do not pull splices into raceways or make splices in conduit bodies or wiring gutters.
 - 2. Remove appropriate amount of conductor insulation for making connections without cutting, nicking or damaging conductors.
 - 3. Do not remove conductor strands to facilitate insertion into connector.
 - 4. Clean contact surfaces on conductors and connectors to suitable remove corrosion, oxides, and other contaminates. Do not use wire brush on plated connector surfaces.
 - 5. Mechanical Connectors: Secure connections according to manufacturer's recommended torque settings.
- N. Insulate splices and taps that are made with uninsulated connectors using methods suitable for the application, with insulation and mechanical strength at least equivalent to unspliced conductors.
 - 1. Dry Locations: Use insulating covers specifically designed for the connectors, electrical tape, or heat shrink tubing.
 - a. For taped connections, first apply adequate amount of rubber splicing electrical tape or electrical filler tape, followed by outer covering of vinyl insulating electrical tape.
 - 2. Damp Locations: Use insulating covers specifically designed for the connectors, electrical tape, or heat shrink tubing.

- a. For connections with insulating covers, apply outer covering of moisture sealing electrical tape.
- b. For taped connections, follow same procedure as for dry locations but apply outer covering of moisture sealing electrical tape.
- O. Insulate ends of spare conductors using vinyl insulating electrical tape.
- P. Field-Applied Color Coding: Where vinyl color coding electrical tape is used in lieu of integrally colored insulation as permitted in Part 2 under "Color Coding", apply half overlapping turns of tape at each termination and at each location conductors are accessible.
- Q. Identify conductors and cables in accordance with Section 26 05 53.
- R. Install firestopping to preserve fire resistance rating of partitions and other elements, using materials and methods specified in Section 07 84 00.
- S. Unless specifically indicated to be excluded, provide final connections to all equipment and devices, including those furnished by others, as required for a complete operating system.

3.04 FIELD QUALITY CONTROL

- A. Inspect and test in accordance with NETA ATS, except Section 4.
- B. Perform inspections and tests listed in NETA ATS, Section 7.3.2. The insulation resistance test is required for all conductors. The resistance test for parallel conductors listed as optional is not required.
 - 1. Disconnect surge protective devices (SPDs) prior to performing any high potential testing. Replace SPDs damaged by performing high potential testing with SPDs connected.
- C. Correct deficiencies and replace damaged or defective conductors and cables.

END OF SECTION

SECTION 26 05 26
GROUNDING AND BONDING FOR ELECTRICAL SYSTEMS

PART 1 GENERAL**1.01 SECTION INCLUDES**

- A. Grounding and bonding requirements.
- B. Conductors for grounding and bonding.
- C. Connectors for grounding and bonding.
- D. Ground bars.
- E. Ground rod electrodes.
- F. Ground plate electrodes.
- G. Ground access wells.

1.02 RELATED REQUIREMENTS

- A. Section 26 05 19 - Low-Voltage Electrical Power Conductors and Cables: Additional requirements for conductors for grounding and bonding, including conductor color coding.

1.03 REFERENCE STANDARDS

- A. IEEE 81 - IEEE Guide for Measuring Earth Resistivity, Ground Impedance, and Earth Surface Potentials of a Grounding System; 2012.
- B. NECA 1 - Standard for Good Workmanship in Electrical Construction; 2015.
- C. NEMA GR 1 - Grounding Rod Electrodes and Grounding Rod Electrode Couplings; 2017.
- D. NETA ATS - Standard For Acceptance Testing Specifications For Electrical Power Equipment And Systems; 2021.
- E. NFPA 70 - National Electrical Code; Most Recent Edition Adopted by Authority Having Jurisdiction, Including All Applicable Amendments and Supplements.
- F. UL 467 - Grounding and Bonding Equipment; Current Edition, Including All Revisions.

1.04 ADMINISTRATIVE REQUIREMENTS

- A. Coordination:
 - 1. Verify exact locations of underground metal water service pipe entrances to building.
 - 2. Coordinate the work with other trades to provide steel reinforcement complying with specified requirements for concrete-encased electrode.
 - 3. Notify Architect of any conflicts with or deviations from Contract Documents. Obtain direction before proceeding with work.
- B. Sequencing:
 - 1. Do not install ground rod electrodes until final backfill and compaction is complete.

1.05 SUBMITTALS

- A. Product Data: Provide manufacturer's standard catalog pages and data sheets for grounding and bonding system components.
- B. Manufacturer's Instructions: Indicate application conditions and limitations of use stipulated by product testing agency. Include instructions for storage, handling, protection, examination, preparation, and installation of product.
- C. Field quality control test reports.
- D. Project Record Documents: Record actual locations of grounding electrode system components and connections.

1.06 QUALITY ASSURANCE

- A. Comply with requirements of NFPA 70.
- B. Manufacturer Qualifications: Company specializing in manufacturing the products specified in this section with minimum three years documented experience.

- C. Product Listing Organization Qualifications: An organization recognized by OSHA as a Nationally Recognized Testing Laboratory (NRTL) and acceptable to authorities having jurisdiction.

1.07 DELIVERY, STORAGE, AND HANDLING

- A. Receive, inspect, handle, and store products in accordance with manufacturer's instructions.

PART 2 PRODUCTS

2.01 GROUNDING AND BONDING REQUIREMENTS

- A. Existing Work: Where existing grounding and bonding system components are indicated to be reused, they may be reused only where they are free from corrosion, integrity and continuity are verified, and where acceptable to the authority having jurisdiction.
- B. Do not use products for applications other than as permitted by NFPA 70 and product listing.
- C. Unless specifically indicated to be excluded, provide all required components, conductors, connectors, conduit, boxes, fittings, supports, accessories, etc. as necessary for a complete grounding and bonding system.
- D. Where conductor size is not indicated, size to comply with NFPA 70 but not less than applicable minimum size requirements specified.
- E. Grounding System Resistance:
 - 1. Achieve specified grounding system resistance under normally dry conditions unless otherwise approved by Architect. Precipitation within the previous 48 hours does not constitute normally dry conditions.
 - 2. Grounding Electrode System: Not greater than 5 ohms to ground, when tested according to IEEE 81 using "fall-of-potential" method.
 - 3. Between Grounding Electrode System and Major Electrical Equipment Frames, System Neutral, and Derived Neutral Points: Not greater than 0.5 ohms, when tested using "point-to-point" methods.
- F. Grounding Electrode System:
 - 1. Provide connection to required and supplemental grounding electrodes indicated to form grounding electrode system.
 - a. Provide continuous grounding electrode conductors without splice or joint.
 - b. Install grounding electrode conductors in raceway where exposed to physical damage. Bond grounding electrode conductor to metallic raceways at each end with bonding jumper.
 - 2. Metal Underground Water Pipe(s):
 - a. Provide connection to underground metal domestic and fire protection (where present) water service pipe(s) that are in direct contact with earth for at least 10 feet at an accessible location not more than 5 feet from the point of entrance to the building.
 - b. Provide bonding jumper(s) around insulating joints/pipes as required to make pipe electrically continuous.
 - c. Provide bonding jumper around water meter of sufficient length to permit removal of meter without disconnecting jumper.
 - 3. Concrete-Encased Electrode:
 - a. Provide connection to concrete-encased electrode consisting of not less than 20 feet of either steel reinforcing bars or bare copper conductor not smaller than 4 AWG embedded within concrete foundation or footing that is in direct contact with earth in accordance with NFPA 70.
 - 4. Ground Rod Electrode(s):
 - a. Provide three electrodes in an equilateral triangle configuration unless otherwise indicated or required.
 - b. Space electrodes not less than 10 feet from each other and any other ground electrode.

- c. Where location is not indicated, locate electrode(s) at least 5 feet outside building perimeter foundation as near as possible to electrical service entrance; where possible, locate in softscape (uncovered) area.
 - d. Provide ground access well for each electrode.
 5. Provide additional ground electrode(s) as required to achieve specified grounding electrode system resistance.
 6. Ground Bar: Provide ground bar, separate from service equipment enclosure, for common connection point of grounding electrode system bonding jumpers as permitted in NFPA 70. Connect grounding electrode conductor provided for service-supplied system grounding to this ground bar.
 - a. Ground Bar Size: 1/4 by 2 by 12 inches unless otherwise indicated or required.
 - b. Where ground bar location is not indicated, locate in accessible location as near as possible to service disconnect enclosure.
 - c. Ground Bar Mounting Height: 18 inches above finished floor unless otherwise indicated.
 - G. Service-Supplied System Grounding:
 1. For each service disconnect, provide grounding electrode conductor to connect neutral (grounded) service conductor to grounding electrode system. Unless otherwise indicated, make connection at neutral (grounded) bus in service disconnect enclosure.
 2. For each service disconnect, provide main bonding jumper to connect neutral (grounded) bus to equipment ground bus where not factory-installed. Do not make any other connections between neutral (grounded) conductors and ground on load side of service disconnect.
 - H. Grounding for Separate Building or Structure Supplied by Feeder(s) or Branch Circuits:
 1. Provide grounding electrode system for each separate building or structure.
 2. Provide equipment grounding conductor routed with supply conductors.
 3. For each disconnecting means, provide grounding electrode conductor to connect equipment ground bus to grounding electrode system.
 4. Do not make any connections and remove any factory-installed jumpers between neutral (grounded) conductors and ground.
 - I. Bonding and Equipment Grounding:
 1. Provide bonding for equipment grounding conductors, equipment ground busses, metallic equipment enclosures, metallic raceways and boxes, device grounding terminals, and other normally non-current-carrying conductive materials enclosing electrical conductors/equipment or likely to become energized as indicated and in accordance with NFPA 70.
 2. Provide insulated equipment grounding conductor in each feeder and branch circuit raceway. Do not use raceways as sole equipment grounding conductor.
 3. Where circuit conductor sizes are increased for voltage drop, increase size of equipment grounding conductor proportionally in accordance with NFPA 70.
 4. Unless otherwise indicated, connect wiring device grounding terminal to branch circuit equipment grounding conductor and to outlet box with bonding jumper.
 5. Terminate branch circuit equipment grounding conductors on solidly bonded equipment ground bus only. Do not terminate on neutral (grounded) or isolated/insulated ground bus.
 6. Provide bonding jumper across expansion or expansion/deflection fittings provided to accommodate conduit movement.
 7. Provide bonding for interior metal piping systems in accordance with NFPA 70. This includes, but is not limited to:
 - a. Metal water piping where not already effectively bonded to metal underground water pipe used as grounding electrode.
 - b. Metal gas piping.
 8. Provide bonding for metal building frame.
 - J. Communications Systems Grounding and Bonding:

1. Provide intersystem bonding termination at service equipment or metering equipment enclosure and at disconnecting means for any additional buildings or structures in accordance with NFPA 70.
2. Provide bonding jumper in raceway from intersystem bonding termination to each communications room or backboard and provide ground bar for termination.
 - a. Bonding Jumper Size: 6 AWG, unless otherwise indicated or required.
 - b. Ground Bar Size: 1/4 by 2 by 12 inches unless otherwise indicated or required.
 - c. Ground Bar Mounting Height: 18 inches above finished floor unless otherwise indicated.

2.02 GROUNDING AND BONDING COMPONENTS

- A. General Requirements:
 1. Provide products listed, classified, and labeled as suitable for the purpose intended.
 2. Provide products listed and labeled as complying with UL 467 where applicable.
- B. Conductors for Grounding and Bonding, in Addition to Requirements of Section 26 05 26:
 1. Use insulated copper conductors unless otherwise indicated.
 - a. Exceptions:
 - 1) Use bare copper conductors where installed underground in direct contact with earth.
 - 2) Use bare copper conductors where directly encased in concrete (not in raceway).
- C. Connectors for Grounding and Bonding:
 1. Description: Connectors appropriate for the application and suitable for the conductors and items to be connected; listed and labeled as complying with UL 467.
 2. Unless otherwise indicated, use exothermic welded connections for underground, concealed and other inaccessible connections.
 3. Unless otherwise indicated, use exothermic welded connections for accessible connections.
 4. Manufacturers - Exothermic Welded Connections:
- D. Ground Bars:
 1. Description: Copper rectangular ground bars with mounting brackets and insulators.
 2. Size: As indicated.
 3. Holes for Connections: As indicated or as required for connections to be made.
 4. Manufacturers:
- E. Ground Rod Electrodes:
 1. Comply with NEMA GR 1.
 2. Material: Copper-bonded (copper-clad) steel.
 3. Size: 3/4 inch diameter by 10 feet length, unless otherwise indicated.
 4. Manufacturers:
- F. Ground Plate Electrodes:
 1. Material: Copper.
 2. Size: 24 by 24 by 1/4 inches, unless otherwise indicated.
- G. Ground Access Wells:
 1. Description: Open bottom round or rectangular well with access cover for testing and inspection; suitable for the expected load at the installed location.
 2. Size: As required to provide adequate access for testing and inspection, but not less than minimum size requirements specified.
 3. Depth: As required to extend below frost line to prevent frost upheaval, but not less than 10 inches.
 4. Cover: Factory-identified by permanent means with word "GROUND".
 5. Manufacturers:

PART 3 EXECUTION**3.01 EXAMINATION**

- A. Verify that work likely to damage grounding and bonding system components has been completed.
- B. Verify that field measurements are as indicated.
- C. Verify that conditions are satisfactory for installation prior to starting work.

3.02 INSTALLATION

- A. Install products in accordance with manufacturer's instructions.
- B. Perform work in accordance with NECA 1 (general workmanship).
- C. Ground Rod Electrodes: Unless otherwise indicated, install ground rod electrodes vertically. Where encountered rock prohibits vertical installation, install at 45 degree angle or bury horizontally in trench at least 30 inches (750 mm) deep in accordance with NFPA 70 or provide ground plates.
 - 1. Outdoor Installations: Unless otherwise indicated, install with top of rod 6 inches below finished grade.
 - 2. Indoor Installations: Unless otherwise indicated, install with 4 inches of top of rod exposed.
- D. Ground Plate Electrodes: Unless otherwise indicated, install ground plate electrodes at a depth of not less than 30 inches.
- E. Make grounding and bonding connections using specified connectors.
 - 1. Remove appropriate amount of conductor insulation for making connections without cutting, nicking or damaging conductors. Do not remove conductor strands to facilitate insertion into connector.
 - 2. Remove nonconductive paint, enamel, or similar coating at threads, contact points, and contact surfaces.
 - 3. Exothermic Welds: Make connections using molds and weld material suitable for the items to be connected in accordance with manufacturer's recommendations.
 - 4. Mechanical Connectors: Secure connections according to manufacturer's recommended torque settings.
 - 5. Compression Connectors: Secure connections using manufacturer's recommended tools and dies.
- F. Identify grounding and bonding system components in accordance with Section 26 05 53.

3.03 FIELD QUALITY CONTROL

- A. See Section 01 40 00 - Quality Requirements, for additional requirements.
- B. Inspect and test in accordance with NETA ATS except Section 4.
- C. Perform inspections and tests listed in NETA ATS, Section 7.13.
- D. Perform ground electrode resistance tests under normally dry conditions. Precipitation within the previous 48 hours does not constitute normally dry conditions.
- E. Investigate and correct deficiencies where measured ground resistances do not comply with specified requirements.
- F. Submit detailed reports indicating inspection and testing results and corrective actions taken.

END OF SECTION

SECTION 26 05 33.13
CONDUIT FOR ELECTRICAL SYSTEMS

PART 1 GENERAL**1.01 SECTION INCLUDES**

- A. Galvanized steel rigid metal conduit (RMC).
- B. Flexible metal conduit (FMC).
- C. Liquidtight flexible metal conduit (LFMC).
- D. Galvanized steel electrical metallic tubing (EMT).
- E. Rigid polyvinyl chloride (PVC) conduit.
- F. High-density polyethylene (HDPE) conduit.

1.02 RELATED REQUIREMENTS

- A. Section 26 05 19 - Low-Voltage Electrical Power Conductors and Cables: Cable assemblies consisting of conductors protected by integral metal armor.
- B. Section 26 05 26 - Grounding and Bonding for Electrical Systems.
 - 1. Includes additional requirements for fittings for grounding and bonding.
- C. Section 26 05 33.16 - Boxes for Electrical Systems.

1.03 REFERENCE STANDARDS

- A. ANSI C80.1 - American National Standard for Electrical Rigid Steel Conduit (ERSC); 2020.
- B. ANSI C80.3 - American National Standard for Electrical Metallic Tubing -- Steel (EMT-S); 2020.
- C. ANSI C80.6 - American National Standard for Electrical Intermediate Metal Conduit; 2018.
- D. ASTM D1002 - Standard Test Method for Apparent Shear Strength of Single-Lap-Joint Adhesively Bonded Metal Specimens by Tension Loading (Metal-to-Metal); 2010 (Reapproved 2019).
- E. ASTM D1598 - Standard Test Methods for Time-to-Failure of Plastic Pipe Under Constant Internal Pressure; 2021.
- F. ASTM D1599 - Standard Test Method for Resistance to Short-Time Hydraulic Pressure of Plastic Pipe, Tubing, and Fittings; 2018.
- G. ASTM D2683 - Standard Specification for Socket-Type Polyethylene Fittings for Outside Diameter-Controlled Polyethylene Pipe and Tubing; 2020.
- H. ASTM D3261 - Standard Specification for Butt Heat Fusion Polyethylene (PE) Plastic Fittings for Polyethylene (PE) Plastic Pipe and Tubing; 2016.
- I. ASTM F1055 - Standard Specification for Electrofusion Type Polyethylene Fittings for Outside Diameter Controlled Polyethylene and Crosslinked Polyethylene (PEX) Pipe and Tubing; 2016a (Reapproved 2022).
- J. ASTM F2160 - Standard Specification for Solid Wall High Density Polyethylene (HDPE) Conduit Based on Controlled Outside Diameter (OD); 2016.
- K. ASTM F2176 - Standard Specification for Mechanical Couplings Used on Polyethylene Conduit, Duct and Innerduct; 2017.
- L. NECA 1 - Standard for Good Workmanship in Electrical Construction; 2015.
- M. NECA 101 - Standard for Installing Steel Conduits (Rigid, IMC, EMT); 2020.
- N. NECA 111 - Standard for Installing Nonmetallic Raceways (RNC, ENT, LFNC); 2017.
- O. NEMA FB 1 - Fittings, Cast Metal Boxes, and Conduit Bodies for Conduit, Electrical Metallic Tubing, and Cable; 2014.
- P. NEMA TC 2 - Electrical Polyvinyl Chloride (PVC) Conduit; 2020.

- Q. NEMA TC 3 - Polyvinyl Chloride (PVC) Fittings for Use with Rigid PVC Conduit and Tubing; 2021.
- R. NEMA TC 7 - Solid-Wall Coilable and Straight Electrical Polyethylene Conduit; 2021.
- S. NFPA 70 - National Electrical Code; Most Recent Edition Adopted by Authority Having Jurisdiction, Including All Applicable Amendments and Supplements.
- T. UL 1 - Flexible Metal Conduit; Current Edition, Including All Revisions.
- U. UL 6 - Electrical Rigid Metal Conduit-Steel; Current Edition, Including All Revisions.
- V. UL 360 - Liquid-Tight Flexible Metal Conduit; Current Edition, Including All Revisions.
- W. UL 514B - Conduit, Tubing, and Cable Fittings; Current Edition, Including All Revisions.
- X. UL 651 - Schedule 40, 80, Type EB and A Rigid PVC Conduit and Fittings; Current Edition, Including All Revisions.
- Y. UL 651A - Schedule 40 and 80 High Density Polyethylene (HDPE) Conduit; Current Edition, Including All Revisions.
- Z. UL 746C - Polymeric Materials – Use in Electrical Equipment Evaluations; Current Edition, Including All Revisions.
- AA. UL 797 - Electrical Metallic Tubing-Steel; Current Edition, Including All Revisions.
- BB. UL 1203 - Explosion-Proof and Dust-Ignition-Proof Electrical Equipment for Use in Hazardous (Classified) Locations; Current Edition, Including All Revisions.
- CC. UL 1242 - Electrical Intermediate Metal Conduit-Steel; Current Edition, Including All Revisions.
- DD. UL 2419 - Outline of Investigation for Electrically Conductive Corrosion Resistant Compounds; Current Edition, Including All Revisions.

1.04 ADMINISTRATIVE REQUIREMENTS

- A. Coordination:
 - 1. Coordinate minimum sizes of conduits with actual type and quantity of conductors to be installed, including adjustments for conductor sizes increased for voltage drop.
 - 2. Coordinate arrangement of conduits with structural members, ductwork, piping, equipment, and other potential conflicts.
 - 3. Verify exact conduit termination locations required for boxes, enclosures, and equipment.
 - 4. Coordinate work to provide roof penetrations that preserve integrity of roofing system and do not void roof warranty.
 - 5. Notify Architect of conflicts with or deviations from Contract Documents. Obtain direction before proceeding with work.
- B. Sequencing:
 - 1. Do not begin installation of conductors and cables until installation of conduit between termination points is complete.

1.05 SUBMITTALS

- A. Product Data: Provide manufacturer's standard catalog pages and data sheets for conduits and fittings.
- B. Project Record Documents: Record actual routing for conduits installed underground, conduits embedded within concrete slabs, and conduits 2-inch (53 mm) trade size and larger.

1.06 QUALITY ASSURANCE

- A. Product Listing Organization Qualifications: Organization recognized by OSHA as Nationally Recognized Testing Laboratory (NRTL) and acceptable to authorities having jurisdiction.

1.07 DELIVERY, STORAGE, AND HANDLING

- A. Receive, inspect, handle, and store conduit and fittings in accordance with manufacturer's instructions.

PART 2 PRODUCTS**2.01 CONDUIT APPLICATIONS**

- A. Do not use conduit and associated fittings for applications other than as permitted by NFPA 70, manufacturer's instructions, and product listing.
- B. Unless otherwise indicated and where not otherwise restricted, use conduit types indicated for specified applications. Where more than one listed application applies, comply with most restrictive requirements. Where conduit type for particular application is not specified, use galvanized steel rigid metal conduit.
- C. Underground:
 - 1. Under Slab on Grade: Use rigid PVC conduit.
 - 2. Exterior, Direct-Buried: Use rigid PVC conduit.
 - 3. Exterior, Embedded Within Concrete: Use rigid PVC conduit.
 - 4. Where rigid polyvinyl chloride (PVC) conduit or high-density polyethylene (HDPE) conduit is provided, transition to galvanized steel rigid metal conduit (RMC) where emerging from underground.
 - 5. Where rigid polyvinyl (PVC) conduit larger than 2-inch (53 mm) trade size is provided, use galvanized steel rigid metal conduit (RMC) elbows for bends.
 - 6. Where galvanized steel rigid metal conduit (RMC) or galvanized steel intermediate metal conduit (IMC) is installed in direct contact with earth, use corrosion protection tape, factory-applied corrosion protection coating, or field-applied corrosion protection compound acceptable to authorities having jurisdiction to provide supplementary corrosion protection.
 - 7. Where steel conduit emerges from concrete into soil, use corrosion protection tape to provide supplementary corrosion protection for a minimum of 4 inches on either side of where conduit emerges.
- D. Embedded Within Concrete:
 - 1. Within Slab on Grade (within structural slabs only where approved by Structural Engineer): Use rigid PVC conduit.
 - 2. Within Slab Above Ground (within structural slabs only where approved by Structural Engineer): Use rigid PVC conduit.
 - 3. Within Concrete Walls Above Ground: Use rigid PVC conduit.
 - 4. Where rigid polyvinyl (PVC) conduit is provided, transition to galvanized steel rigid metal conduit (RMC) where emerging from concrete.
 - 5. Where galvanized steel electrical metallic tubing (EMT) or galvanized steel rigid metal conduit (RMC) emerges from concrete into salt air, use corrosion protection tape, factory-applied corrosion protection coating, or field-applied corrosion protection compound acceptable to authorities having jurisdiction to provide supplementary corrosion protection for minimum of 4 inches on either side of where conduit emerges.
- E. Concealed Within Hollow Masonry Walls: Use galvanized steel rigid metal conduit or electrical metallic tubing (EMT).
- F. Concealed Within Hollow Stud Walls: Use electrical metallic tubing (EMT).
- G. Concealed Above Accessible Ceilings: Use electrical metallic tubing (EMT).
- H. Interior, Damp or Wet Locations: Use galvanized steel rigid metal conduit (RMC).
- I. Exposed, Interior, Not Subject to Physical Damage: Use electrical metallic tubing (EMT).
- J. Exposed, Interior, Subject to Physical Damage: Use galvanized steel rigid metal conduit.
 - 1. Locations subject to physical damage include, but are not limited to:
 - a. Where exposed below 8 feet, except within electrical and communication rooms or closets.
 - b. Where exposed below 20 feet in warehouse areas.
- K. Exposed, Exterior: Use galvanized steel rigid metal conduit.

- L. Concealed, Exterior, Not Embedded in Concrete or in Contact With Earth: Use galvanized steel rigid metal conduit or electrical metallic tubing (EMT).
- M. Flexible Connections to Luminaires Above Accessible Ceilings: Use flexible metal conduit (FMC).
 - 1. Maximum Length: 6 feet.
- N. Flexible Connections to Vibrating Equipment:
 - 1. Dry Locations: Use flexible metal conduit (FMC).
 - 2. Damp, Wet, or Corrosive Locations: Use liquidtight flexible metal conduit (LFMC).
 - 3. Maximum Length: 6 feet unless otherwise indicated.
 - 4. Vibrating equipment includes, but is not limited to:
 - a. Transformers.
 - b. Motors.

2.02 CONDUIT - GENERAL REQUIREMENTS

- A. Comply with NFPA 70.
- B. Electrical Service Conduits: See Section 26 21 00 for additional requirements.
- C. Fittings for Grounding and Bonding: See Section 26 05 26 for additional requirements.
- D. Provide conduit, fittings, supports, and accessories required for complete raceway system.
- E. Provide products listed, classified, and labeled as suitable for purpose intended.
- F. Minimum Conduit Size, Unless Otherwise Indicated:
 - 1. Branch Circuits: 3/4 inch (21 mm) trade size.
 - 2. Underground, Interior: 1 inch (27 mm) trade size.
 - 3. Underground, Exterior: 1-inch trade size.
- G. Where conduit size is not indicated, size to comply with NFPA 70 but not less than applicable minimum size requirements specified.

2.03 GALVANIZED STEEL RIGID METAL CONDUIT (RMC)

- A. Manufacturers:
 - 1. Allied Tube & Conduit, a division of Atkore International: www.alliedeg.com/#sle.
 - 2. Western Tube, a division of Zekelman Industries: www.westerntube.com/#sle.
 - 3. Wheatland Tube, a division of Zekelman Industries: www.wheatland.com/#sle.
- B. Conduit with integral fittings, such as Allied Tube and Conduit's "Kwik-Couple" are not permitted.
- C. Interior conduits shall be color-coded based on the wiring or system type they serve. Paint shall be factory applied by the manufacturer
 - 1. Normal Power Systems: No color
 - 2. Emergency and Standby Power Systems: Yellow
 - 3. Fire Alarm: Red
 - 4. Security: Orange
 - 5. Telephone and Data: Blue
 - 6. Audio/Visual: Purple
 - 7. Other Low Voltage: Green
- D. Description: NFPA 70, Type RMC galvanized steel rigid metal conduit complying with ANSI C80.1 and listed and labeled as complying with UL 6.
- E. Fittings:
 - 1. Manufacturers:
 - a. ABB; T&B: www.electrification.us.abb.com/#sle.
 - b. Allied Tube & Conduit, a division of Atkore International: www.alliedeg.us/#sle.
 - c. Emerson Electric Co; O-Z/Gedney: www.emerson.com/#sle.
 - 2. Nonhazardous Locations: Use fittings complying with NEMA FB 1 and listed and labeled as complying with UL 514B or UL 6.

3. Hazardous/Classified Locations: Use fittings listed and labeled as complying with UL 1203 for classification of installed location.
4. Material: Use steel or malleable iron.
 - a. Do not use die cast zinc fittings.
5. Connectors and Couplings: Use threaded type fittings only. Threadless fittings, including set screw and compression/gland types, are not permitted.

2.04 FLEXIBLE METAL CONDUIT (FMC)

- A. Manufacturers:
 1. AFC Cable Systems, a division of Atkore International: www.afcweb.com/#sle.
- B. Description: NFPA 70, Type FMC standard-wall steel flexible metal conduit listed and labeled as complying with UL 1, and listed for use in classified firestop systems.
- C. Fittings:
 1. Manufacturers:
 - a. ABB; T&B: www.electrification.us.abb.com/#sle.
 - b. Emerson Electric Co; O-Z/Gedney: www.emerson.com/#sle.
 2. Description: Fittings complying with NEMA FB 1 and listed and labeled as complying with UL 514B.
 3. Material: Use steel or malleable iron.
 - a. Do not use die cast zinc fittings.

2.05 LIQUIDTIGHT FLEXIBLE METAL CONDUIT (LFMC)

- A. Manufacturers:
 1. AFC Cable Systems, a division of Atkore International: www.afcweb.com/#sle.
- B. Description: NFPA 70, Type LFMC polyvinyl chloride (PVC) jacketed steel flexible metal conduit listed and labeled as complying with UL 360.
- C. Fittings:
 1. Manufacturers:
 - a. ABB; T&B: www.electrification.us.abb.com/#sle.
 - b. Emerson Electric Co; O-Z/Gedney: www.emerson.com/#sle.
 2. Description: Fittings complying with NEMA FB 1 and listed and labeled as complying with UL 514B.
 3. Material: Use steel or malleable iron.
 - a. Do not use die cast zinc fittings.

2.06 GALVANIZED STEEL ELECTRICAL METALLIC TUBING (EMT)

- A. Manufacturers:
 1. Allied Tube & Conduit, a division of Atkore International: www.alliedeg.com/#sle.
 2. Western Tube, a division of Zekelman Industries: www.westerntube.com/#sle.
 3. Wheatland Tube, a division of Zekelman Industries: www.wheatland.com/#sle.
- B. Description: NFPA 70, Type EMT galvanized steel electrical metallic tubing complying with ANSI C80.3 and listed and labeled as complying with UL 797.
- C. Conduits with integral fittings similar to Allied Tube & Conduit's "Kwik-Fit" shall not be used.
- D. Interior conduits shall be color-coded based on the wiring or system type they serve. Paint shall be factory applied by the manufacturer
 1. Normal Power Systems: No color
 2. Emergency and Standby Power Systems: Yellow
 3. Fire Alarm: Red
 4. Security: Orange
 5. Telephone and Data: Blue
 6. Audio/Visual: Purple
 7. Other Low Voltage: Green
- E. Fittings:

1. Manufacturers:
 - a. ABB; T&B: www.electrification.us.abb.com/#sle.
 - b. Allied Tube & Conduit, a division of Atkore International: www.alliedeg.us/#sle.
 - c. Emerson Electric Co; O-Z/Gedney: www.emerson.com/#sle.
2. Description: Fittings complying with NEMA FB 1 and listed and labeled as complying with UL 514B.
3. Material: Use steel or malleable iron.
 - a. Do not use die cast zinc fittings.
4. Connectors and Couplings: Use compression/gland or set-screw type.
 - a. Do not use indenter type connectors and couplings.

2.07 RIGID POLYVINYL CHLORIDE (PVC) CONDUIT

- A. Manufacturers:
 1. ABB; Carlon: www.carlon.com/#sle.
 2. Allied Tube & Conduit, a division of Atkore International: www.alliedeg.com/#sle.
 3. Cantex Inc: www.cantexinc.com/#sle.
- B. Description: NFPA 70, Type PVC rigid polyvinyl chloride conduit complying with NEMA TC 2 and listed and labeled as complying with UL 651; Schedule 40 unless otherwise indicated, Schedule 80 where subject to physical damage; rated for use with conductors rated 90 degrees C.
- C. Fittings:
 1. Expansion fittings similar to Carlon's "E945" series shall not be used.
 2. Manufacturer: Same as manufacturer of conduit to be connected.
 3. Description: Fittings complying with NEMA TC 3 and listed and labeled as complying with UL 651; material to match conduit.

2.08 HIGH-DENSITY POLYETHYLENE (HDPE) CONDUIT

- A. Manufacturers:
 1. ABB; Carlon: www.electrification.us.abb.com/#sle.
 2. Blue Diamond Industries, LLC: www.bdiky.com/#sle.
 3. Eastern Wire + Conduit, a division of Atkore International: www.easternwire.com/#sle.
- B. Description: NFPA 70, Type HDPE high-density polyethylene solid-wall conduit complying with ASTM F2160 and NEMA TC 7; list and label as complying with UL 651A; Schedule 40 unless otherwise indicated.
- C. Joining Methods: Approved by HDPE conduit manufacturer.
- D. Mechanical Fittings: Comply with ASTM F2176; list and label as complying with UL 651A.
- E. Butt Heat Fusion Fittings: Comply with ASTM D3261.
- F. Socket Fusion Fittings: Comply with ASTM D2683.
- G. Electrofusion Fittings: Comply with ASTM F1055.

2.09 ACCESSORIES

- A. Corrosion Protection Tape: PVC-based, minimum thickness of 20 mil, 0.020 inch.
- B. Conduit Joint Compound: Corrosion-resistant, electrically conductive compound listed as complying with UL 2419; suitable for use with conduit to be installed.
- C. Solvent Cement for PVC Conduit and Fittings: As recommended by manufacturer of conduit and fittings to be installed.
- D. Adhesive for HDPE Conduit:
 1. Specifically designed for bonding dissimilar materials in lieu of transition fittings, including but not limited to polyethylene, fiberglass, PVC, aluminum, and steel; UL 746C recognized.
 2. Approved by adhesive manufacturer for use with materials to be joined.
 3. Adhesive Shear Strength: Not less than 100 psi, when tested in accordance with ASTM D1002.

4. Hydrostatic Pressure Resistance: No leaks, when tested in accordance with ASTM D1598 at 120 psi for 1,000 hours and when tested in accordance with ASTM D1599 at 250 psi.
5. Products:
 - a. American Polywater Corporation; Polywater BonDuit Conduit Adhesive: www.polywater.com/#sle.
- E. Pull Strings: Use nylon or polyester tape with average breaking strength of not less than 1,250 lbf.
- F. Foam Conduit Sealant:
 1. Removable, two-part, closed-cell foam, specifically designed for sealing conduit openings against water, moisture, gases, and dust.
 2. Suitable for use with conductors/cables and associated insulation/jackets to be installed.
 3. Rated to hold minimum of 10 ft water head pressure.
 4. Products:
 - a. American Polywater Corporation; Polywater AFT Foam Duct Sealant: www.polywater.com/#sle.
 - b. American Polywater Corporation; Polywater FST Foam Duct Sealant: www.polywater.com/#sle.
- G. Conduit Mechanical Seals:
 1. Listed as complying with UL 514B.
 2. Specifically designed for sealing conduit openings against water, moisture, gases, and dust.
 3. Suitable for sealing around conductors/cables to be installed.
 4. Products:
 - a. American Polywater Corporation; PHRD SG Mechanical Seals: www.polywater-haufftechnik.com/#sle.
- H. Sealing Compound for Hazardous/Classified Location Sealing Fittings: Listed for use with particular fittings to be installed.
- I. Sealing Systems for Concrete Penetrations:
 1. Sleeves: Provide water stop ring or cement coating that bonds to concrete to prevent water infiltration.
 2. Rate for minimum of 40 psig; suitable for sealing around conduits to be installed.
 3. Products:
 - a. American Polywater Corporation; PZVR Cement-Coated Concrete Wall Sleeves: www.polywater-haufftechnik.com/#sle.
 - b. American Polywater Corporation; PHSD Mechanical Seals: www.polywater-haufftechnik.com/#sle.
 - c. American Polywater Corporation; PHSI 150 Varia Double Wall Inserts: www.polywater-haufftechnik.com/#sle.
 - d. American Polywater Corporation; PGKD Modular Seals: www.polywater-haufftechnik.com/#sle.
- J. Sealing Systems for Roof Penetrations: Premanufactured components and accessories as required to preserve integrity of roofing system and maintain roof warranty; suitable for conduits and roofing system to be installed; designed to accommodate existing penetrations where applicable.
 1. Products:
 - a. Alta Products, LLC; Sigrist Pipe Chase Housing, Curbs, and Exit Seals: www.altaproductsllc.com/#sle.
 - b. Menzies Metal Products; Electrical Roof Stack and Cap: www.menzies-metal.com/#sle.
 - c. Menzies Metal Products; Electrical Retro Box: www.menzies-metal.com/#sle.
- K. Flashing Panels for Exterior Wall Penetrations: Premanufactured components and accessories as required to preserve integrity of building envelope; suitable for conduits and facade materials

- to be installed.
1. Products:
 - a. Quickflash Weatherproofing Products, Inc: www.quickflashproducts.com/#sle.
 - L. Duct Bank Spacers: Nonmetallic; designed for maintaining conduit/duct spacing for concrete encasement in open trench installation; suitable for conduit/duct arrangement to be installed.
 1. Products:
 - a. Advance Products & Systems, LLC; Duct Bank Spacers: www.apsonline.com/#sle
 - M. Firestop Sleeves: Listed; provide as required to preserve fire resistance rating of building elements.
 1. Products:
 - a. HoldRite, a brand of Reliance Worldwide Corporation; HydroFlame Pro Series/HydroFlame Custom Built: www.holdrite.com/#sle.
 - N. Bore Spacers: Nonmetallic; designed for maintaining conduit/duct spacing for installation within casing; furnished with roller wheels to facilitate installation, openings to facilitate grout flow, and holes for stabilization cable; suitable for casing and conduit/duct arrangement to be installed.
 1. Products:
 - a. Advance Products & Systems, LLC; Bore Spacers: www.apsonline.com/#sle.

PART 3 EXECUTION

3.01 EXAMINATION

- A. Verify that field measurements are as indicated.
- B. Verify that mounting surfaces are ready to receive conduits.
- C. Verify that conditions are satisfactory for installation prior to starting work.

3.02 INSTALLATION

- A. Install products in accordance with manufacturer's instructions.
- B. Install conduit in accordance with NECA 1.
- C. Install galvanized steel rigid metal conduit (RMC) in accordance with NECA 101.
- D. Install intermediate metal conduit (IMC) in accordance with NECA 101.
- E. Install rigid polyvinyl chloride (PVC) conduit in accordance with NECA 111.
- F. Conduit Routing:
 1. Unless dimensioned, conduit routing indicated is diagrammatic.
 2. When conduit destination is indicated without specific routing, determine exact routing required.
 3. Conceal conduits unless specifically indicated to be exposed.
 4. Conduits in the following areas may be exposed, unless otherwise indicated:
 - a. Electrical rooms.
 - b. Mechanical equipment rooms.
 - c. Within joists in areas with no ceiling.
 5. Unless otherwise approved, do not route exposed conduits:
 - a. Across floors.
 - b. Across top of parapet walls.
 - c. Across building exterior surfaces.
 6. Conduits installed underground or embedded in concrete may be routed in shortest possible manner unless otherwise indicated. Route other conduits parallel or perpendicular to building structure and surfaces, following surface contours where practical.
 7. Arrange conduit to maintain adequate headroom, clearances, and access.
 8. For power conduits, arrange conduit to provide no more than the equivalent of three 90 degree bends between pull points.
 9. For low voltage conduits, arrange conduit to provide no more than the equivalent of two 90 degree bends between pull points.

10. Arrange conduit to provide no more than 150 feet between pull points.
 11. Route conduits above water and drain piping where possible.
 12. Arrange conduit to prevent moisture traps. Provide drain fittings at low points and at sealing fittings where moisture may collect.
 13. Maintain minimum clearance of 6 inches between conduits and piping for other systems.
 14. Maintain minimum clearance of 12 inches between conduits and hot surfaces. This includes, but is not limited to:
 - a. Heaters.
 - b. Hot water piping.
 - c. Flues.
 15. Group parallel conduits in same area on common rack.
- G. Conduit Support:
1. Secure and support conduits in accordance with NFPA 70 using suitable supports and methods approved by authorities having jurisdiction; see Section 26 05 29.
 2. Provide independent support from building structure. Do not provide support from piping, ductwork, or other systems.
 3. Installation Above Suspended Ceilings: Do not provide support from ceiling support system. Do not provide support from ceiling grid or allow conduits to lay on ceiling tiles.
 4. Use conduit strap to support single surface-mounted conduit.
 - a. Use clamp back spacer with conduit strap for damp and wet locations to provide space between conduit and mounting surface.
 5. Use metal channel/strut with accessory conduit clamps to support multiple parallel surface-mounted conduits.
 6. Use conduit clamp to support single conduit from beam clamp or threaded rod.
 7. Use trapeze hangers assembled from threaded rods and metal channel/strut with accessory conduit clamps to support multiple parallel suspended conduits.
 8. Use nonpenetrating rooftop supports to support conduits routed across rooftops, where approved.
 9. Use of spring steel conduit clips for support of conduits is not permitted.
 10. Use of wire for support of conduits is not permitted.
 11. Where conduit support intervals specified in NFPA 70 and NECA standards differ, comply with most stringent requirements.
- H. Connections and Terminations:
1. Use approved zinc-rich paint or conduit joint compound on field-cut threads of galvanized steel conduits prior to making connections.
 2. Where two threaded conduits must be joined and neither can be rotated, use three-piece couplings or split couplings. Do not use running threads.
 3. Use suitable adapters where required to transition from one type of conduit to another.
 4. Provide drip loops for liquidtight flexible conduit connections to prevent drainage of liquid into connectors.
 5. Terminate threaded conduits in boxes and enclosures using threaded hubs or double lock nuts for dry locations and raintight hubs for wet locations.
 6. Provide insulating bushings, insulated throats, or listed metal fittings with smooth, rounded edges at conduit terminations to protect conductors.
 7. Secure joints and connections to provide mechanical strength and electrical continuity.
- I. Penetrations:
1. Do not penetrate or otherwise notch or cut structural members, including footings and grade beams, without approval of Structural Engineer.
 2. Make penetrations perpendicular to surfaces unless otherwise indicated.
 3. Provide sleeves for penetrations as indicated or as required to facilitate installation. Set sleeves flush with exposed surfaces unless otherwise indicated or required.
 4. Conceal bends for conduit risers emerging above ground.
 5. Where conduits penetrate waterproof membrane, seal as required to maintain integrity of membrane.

6. Make penetrations for roof-mounted equipment within associated equipment openings and curbs where possible to minimize roofing system penetrations. Where penetrations are necessary, seal as indicated or as required to preserve integrity of roofing system and maintain roof warranty.
 7. Provide metal escutcheon plates for conduit penetrations exposed to public view.
 8. Install firestopping to preserve fire resistance rating of partitions and other elements; see Section 07 84 00.
- J. Underground Installation:
1. Provide trenching and backfilling; see Section 31 23 16.13.
 2. Minimum Cover, Unless Otherwise Indicated or Required:
 - a. Underground, Exterior: 18 inches.
 - b. Under Slab on Grade: 12 inches to bottom of slab.
- K. Embedment Within Structural Concrete Slabs (only where approved by Structural Engineer):
1. Secure conduits to prevent floating or movement during pouring of concrete.
- L. Conduit Movement Provisions: Where conduits are subject to movement, provide expansion and expansion/deflection fittings to prevent damage to enclosed conductors or connected equipment. This includes, but is not limited to:
1. Where conduits cross structural joints intended for expansion, contraction, or deflection.
 2. Where calculated in accordance with NFPA 70 for rigid polyvinyl chloride (PVC) conduit installed above ground to compensate for thermal expansion and contraction.
 3. Where conduits are subject to earth movement by settlement or frost.
- M. Conduit Sealing:
1. Use foam conduit sealant to prevent entry of moisture and gases. This includes, but is not limited to:
 - a. Where conduits enter building from outside.
 - b. Where service conduits enter building from underground distribution system.
 - c. Where conduits enter building from underground.
 - d. Where conduits may transport moisture to contact live parts.
 2. Where conduits cross barriers between areas of potential substantial temperature differential, use foam conduit sealant at accessible point near penetration to prevent condensation. This includes, but is not limited to:
 - a. Where conduits pass from outdoors into conditioned interior spaces.
 - b. Where conduits pass from unconditioned interior spaces into conditioned interior spaces.
 - c. Where conduits penetrate coolers or freezers.
 3. Where conduits cross boundaries of hazardous/classified locations, provide identified/listed sealing fittings or conduit mechanical seals as approved by authorities having jurisdiction; locate as indicated or in accordance with NFPA 70.
- N. Provide pull string in each empty conduit and in conduits where conductors and cables are to be installed by others. Leave minimum slack of 12 inches at each end.
- O. Provide grounding and bonding; see Section 26 05 26.
- P. Identify conduits; see Section 26 05 53.

3.03 FIELD QUALITY CONTROL

- A. See Section 01 40 00 - Quality Requirements for additional requirements.
- B. Repair cuts and abrasions in galvanized finishes using zinc-rich paint recommended by manufacturer. Replace components that exhibit signs of corrosion.
- C. Correct deficiencies and replace damaged or defective conduits.

3.04 CLEANING

- A. Clean interior of conduits to remove moisture and foreign matter.

3.05 PROTECTION

- A. Immediately after installation of conduit, use suitable manufactured plugs to provide protection from entry of moisture and foreign material and do not remove until ready for installation of conductors.

END OF SECTION

SECTION 26 05 33.16
BOXES FOR ELECTRICAL SYSTEMS

PART 1 GENERAL**1.01 SECTION INCLUDES**

- A. Outlet and device boxes up to 100 cubic inches, including those used as junction and pull boxes.
- B. Cabinets and enclosures, including junction and pull boxes larger than 100 cubic inches.
- C. Boxes and enclosures for integrated power, data, and audio/video.
- D. Boxes for hazardous (classified) locations.
- E. Floor boxes.
- F. Underground boxes/enclosures.
- G. Accessories.

1.02 RELATED REQUIREMENTS

- A. Section 26 05 26 - Grounding and Bonding for Electrical Systems.
- B. Section 26 05 33.13 - Conduit for Electrical Systems:
 - 1. Conduit bodies and other fittings.
 - 2. Additional requirements for locating boxes to limit conduit length and/or number of bends between pulling points.
- C. Section 26 27 26 - Wiring Devices:
 - 1. Wall plates.
 - 2. Access floor boxes.

1.03 REFERENCE STANDARDS

- A. NECA 1 - Standard for Good Workmanship in Electrical Construction; 2015.
- B. NECA 130 - Standard for Installing and Maintaining Wiring Devices; 2016.
- C. NEMA 250 - Enclosures for Electrical Equipment (1000 Volts Maximum); 2020.
- D. NEMA FB 1 - Fittings, Cast Metal Boxes, and Conduit Bodies for Conduit, Electrical Metallic Tubing, and Cable; 2014.
- E. NEMA OS 1 - Sheet-Steel Outlet Boxes, Device Boxes, Covers, and Box Supports; 2013 (Reaffirmed 2020).
- F. NFPA 70 - National Electrical Code; Most Recent Edition Adopted by Authority Having Jurisdiction, Including All Applicable Amendments and Supplements.
- G. SCTE 77 - Specifications for Underground Enclosure Integrity; 2017.
- H. UL 50 - Enclosures for Electrical Equipment, Non-Environmental Considerations; Current Edition, Including All Revisions.
- I. UL 50E - Enclosures for Electrical Equipment, Environmental Considerations; Current Edition, Including All Revisions.
- J. UL 508A - Industrial Control Panels; Current Edition, Including All Revisions.
- K. UL 514A - Metallic Outlet Boxes; Current Edition, Including All Revisions.
- L. UL 1203 - Explosion-Proof and Dust-Ignition-Proof Electrical Equipment for Use in Hazardous (Classified) Locations; Current Edition, Including All Revisions.

1.04 ADMINISTRATIVE REQUIREMENTS

- A. Coordination:
 - 1. Coordinate the work with other trades to avoid placement of ductwork, piping, equipment, or other potential obstructions within the dedicated equipment spaces and working clearances for electrical equipment required by NFPA 70.

2. Coordinate arrangement of electrical equipment with the dimensions and clearance requirements of the actual equipment to be installed.
3. Coordinate minimum sizes of boxes with the actual installed arrangement of conductors, clamps, support fittings, and devices, calculated according to NFPA 70.
4. Coordinate minimum sizes of pull boxes with the actual installed arrangement of connected conduits, calculated according to NFPA 70.
5. Coordinate the placement of boxes with millwork, furniture, devices, equipment, etc. installed under other sections or by others.
6. Coordinate the work with other trades to preserve insulation integrity.
7. Coordinate the work with other trades to provide walls suitable for installation of flush-mounted boxes where indicated.
8. Notify Architect of any conflicts with or deviations from Contract Documents. Obtain direction before proceeding with work.

1.05 SUBMITTALS

- A. Product Data: Provide manufacturer's standard catalog pages and data sheets for cabinets and enclosures, floor boxes, and underground boxes/enclosures.
 1. Underground Boxes/Enclosures: Include reports for load testing in accordance with SCTE 77 certified by a professional engineer or an independent testing agency upon request.
- B. Project Record Documents: Record actual locations for outlet and device boxes, pull boxes, cabinets and enclosures, floor boxes, and underground boxes/enclosures.
- C. Maintenance Materials: Furnish the following for Owner's use in maintenance of project.
 1. Keys for Lockable Enclosures: Two of each different key.

1.06 QUALITY ASSURANCE

- A. Comply with requirements of NFPA 70.
- B. Product Listing Organization Qualifications: An organization recognized by OSHA as a Nationally Recognized Testing Laboratory (NRTL) and acceptable to authorities having jurisdiction.

1.07 DELIVERY, STORAGE, AND HANDLING

- A. Receive, inspect, handle, and store products in accordance with manufacturer's instructions.

PART 2 PRODUCTS

2.01 BOXES

- A. General Requirements:
 1. Do not use boxes and associated accessories for applications other than as permitted by NFPA 70 and product listing.
 2. Provide all boxes, fittings, supports, and accessories required for a complete raceway system and to accommodate devices and equipment to be installed.
 3. Provide products listed, classified, and labeled as suitable for the purpose intended.
 4. Where box size is not indicated, size to comply with NFPA 70 but not less than applicable minimum size requirements specified.
 5. Provide grounding terminals within boxes where equipment grounding conductors terminate.
- B. Outlet and Device Boxes Up to 100 cubic inches, Including Those Used as Junction and Pull Boxes:
 1. Use sheet-steel boxes for dry locations unless otherwise indicated or required.
 2. Use cast iron boxes or cast aluminum boxes for damp or wet locations unless otherwise indicated or required; furnish with compatible weatherproof gasketed covers.
 3. Use cast iron boxes or cast aluminum boxes where exposed galvanized steel rigid metal conduit is used.
 4. Use suitable concrete type boxes where flush-mounted in concrete.
 5. Use suitable masonry type boxes where flush-mounted in masonry walls.

6. Use raised covers suitable for the type of wall construction and device configuration where required.
 7. Use shallow boxes where required by the type of wall construction.
 8. Do not use "through-wall" boxes designed for access from both sides of wall.
 9. Sheet-Steel Boxes: Comply with NEMA OS 1, and list and label as complying with UL 514A.
 10. Cast Metal Boxes: Comply with NEMA FB 1, and list and label as complying with UL 514A; furnish with threaded hubs.
 11. Boxes for Supporting Luminaires and Ceiling Fans: Listed as suitable for the type and weight of load to be supported; furnished with fixture stud to accommodate mounting of luminaire where required.
 12. Gangable or sectional boxes shall not be permitted.
 13. Minimum Box Size, Unless Otherwise Indicated:
 - a. Wiring Devices (Other Than Communications Systems Outlets): 4 inch square by 1-1/2 inch deep (100 by 38 mm) trade size.
 - b. Communications Systems Outlets: 4 inch square by 2-1/8 inch (100 by 54 mm) trade size.
 - c. Ceiling Outlets: 4 inch octagonal or square by 1-1/2 inch deep (100 by 38 mm) trade size.
 14. Wall Plates: Comply with Section 26 27 26.
 15. Manufacturers:
 - a. Hubbell Incorporated; RACO Products: www.hubbell-rtb.com/#sle.
 - b. O-Z/Gedney, a brand of Emerson Electric Co: www.emerson.com/#sle.
 - c. Thomas & Betts Corporation: www.tnb.com/#sle.
- C. Cabinets and Enclosures, Including Junction and Pull Boxes Larger Than 100 cubic inches:
1. Comply with NEMA 250, and list and label as complying with UL 50 and UL 50E, or UL 508A.
 2. NEMA 250 Environment Type, Unless Otherwise Indicated:
 - a. Indoor Clean, Dry Locations: Type 1, painted steel.
 - b. Outdoor Locations: Type 3R, painted steel.
 3. Junction and Pull Boxes Larger Than 100 cubic inches:
 - a. Provide screw-cover or hinged-cover enclosures unless otherwise indicated.
 4. Cabinets and Hinged-Cover Enclosures, Other Than Junction and Pull Boxes:
 - a. Provide lockable hinged covers, all locks keyed alike unless otherwise indicated.
 5. Finish for Painted Steel Enclosures: Manufacturer's standard grey unless otherwise indicated.
 6. Manufacturers:
 - a. Cooper B-Line, a division of Eaton Corporation: www.cooperindustries.com/#sle.
 - b. Hoffman, a brand of Pentair Technical Products: www.hoffmanonline.com/#sle.
 - c. Hubbell Incorporated; Wiegmann Products: www.hubbell-wiegmann.com/#sle.
- D. Boxes and Enclosures for Integrated Power, Data, and Audio/Video: Size and configuration as indicated or as required with partitions to separate services; field-connected gangable boxes may be used.
1. Recessed Wall Enclosure for Tele/Data Cabling: In-wall recessed enclosure for the installation of power and low voltage devices to feed residential units.
 - a. 14" wide by 42" tall by 3.75" deep flame-resistant ABS plastic enclosure.
 - b. Multiple 1" and 2" knockouts on the top and bottom of the enclosure for conduit terminations.
 - c. Single-gange knockouts on the bottom of the enclosure for installation of up to (2) single-gang j-boxes for power or low voltage.
 - d. Vented, hinged, and lockable door
 - e. Accessories:
 - 1) Rubber Grommets: Provide 1" and 2" grommets for each knockout removed

- 2) Universal Shelf Bracket: Provide mounting bracket with holes for mounting and velcroing equipment in place. Provide one bracket per data switch, router, hub, or other miscellaneous equipment as required.
- 3) Velcro: Provide 1/2" wide velcro as required to secure equipment and wiring in place, lengths as required.
- 4) CATV Mounting Plate: Provide bracket for secure mounting of F-type CATV connectors, quantity as required.
- 5) Tele/Data Mounting Bracket: Provide bracket for mounting of tele/data patch panels or bracket for installation of QuickPort style telephone and data connectors.
- f. Manufacturer: Leviton 42" Wireless Structured Media Center, model #49605-42P with 5L000-L0K and manufacturer's accessories
2. Recessed Enclosure for Wireless Access Points: In-wall, non-metallic, recessed enclosure for the installation of Wireless Access Points.
 - a. 14" wide by 14" tall by 4" deep flame-resistant ABS plastic enclosure.
 - b. Multiple 1" and 2" knockouts on the top and bottom of the enclosure for conduit terminations.
 - c. Single-gang knockouts on the bottom of the enclosure for installation of up to (2) single gang j-boxes for power or low voltage.
 - d. Vented, hinged, and lockable door.
 - e. Manufacturers: Leviton 14" Wireless Structured Media Center, model #49605-14P with 5L000-L0K
3. Recessed Wall Boxes: In-wall recessed box for the installation of power and low voltage devices behind flat panel displays.
 - a. Provide quantity of gangs as required to feed all power and low voltage devices as shown on plans.
 - b. Low voltage j-box shall accommodate standard Decora style devices in addition to manufacturer's Intelligent Plate Solutions (IPS) devices. Refer to plans for types and quantities of connectors.
 - c. Box shall sit flush with wall, with cover provided over box opening. Cover shall be provided with cable pass-thru.
 - d. Cover color shall be white, unless otherwise noted.
 - e. Manufacturers:
 - 1) FSR Inc; PWB-100 Series: www.fsrinc.com/
4. Recessed Ceiling Boxes: Recessed in-ceiling box for installation of power and low voltage devices to serve a ceiling mounted AV equipment.
 - a. Enclosure shall come standard with (5) 120V outlets, with two duplex and one single outlet. Duplex outlets shall be located within enclosure, single outlet shall be located at the ceiling plane on the exterior of the box.
 - b. Enclosure shall be intended for installation in standard T-bar ceiling grid, with optional mounting kit option for drywall installation. Housing shall be constructed of steel. Provide ceiling tile, cut to size and finish to match adjacent ceiling, for installation in door of enclosure.
 - c. Enclosure shall be provided with optional fan kit.
 - d. Where the installed enclosure is intended to serve a projector, provide projector pole mount option. Pole mount shall be 1-1/2" National Pipe Thread (NPT) fitting, capable of supporting up to 50lbs.
 - e. Provide cable mounting kit for mounting of enclosure to ceiling structure above.
 - f. Provide additional threaded rod mounting kit as required for mounting conditions. Threaded rod kit shall accept 1/4" and 3/8" threaded rod at four hangar bracket locations.
 - g. Manufacturers:
 - 1) Ceiling Enclosure: FSR Inc.; CB-12P with CB-12FAN and CB-MNT1 series : www.fsrinc.com/
5. Wood Floors - Flush Floor Boxes:

- a. Cast iron, watertight body, with fully adjustable height settings to allow for installation flush with flooring.
 - b. Sizes from one to three gangs for multiple power or low voltage feeds. Provide quantity of boxes and gangs as required to feed all devices as noted on plans
 - c. Provide brass carpet plate to transition from adjacent floor surface to floor box, size as required to accommodate quantity of gangs in each box
 - d. Provide brass GFCI style, gasketed, hinged cover plate with flathead-screw style means of securing cover in the closed position.
 - e. Knockouts: 3/4" or 1" Conduit hubs, one per side, per gang.
 - f. Manufacturer:
 - 1) Steel City 60W series floor box, P64 series brass carpet plate, P-64-GFCI cover plate ; www.tnb.com/
6. Wood Floors - Recessed Floor Boxes:
- a. Welded steel housing, with 1/8" steel cover, suitable for installation in wood floors.
 - b. Cover shall have hinged access door with integrated cable pass thru window. Pass-thru window opens down into box to avoid tripping hazards.
 - c. Configurable gang plate dividers and compartment dividers. Provide arrangement of interior compartments as required to accommodate all devices indicated on plans and to separate voltages.
 - d. Provide manufacturer's brackets as required to accommodate all power and low voltage devices within each floor box.
 - e. Manufacturer:
 - 1) Single Gang: FSR Inc. FL-1200 and Four Gang: FSR Inc. FL-1550 ; www.fsrinc.com
7. Concrete Floors - Flush Floor Boxes:
- a. Cast iron, watertight body, with fully adjustable height settings to allow for installation flush with flooring
 - b. Sizes from one to four gangs for multiple power or low voltage feeds. Sizes from one to three gangs for shallow boxes. Provide quantity of boxes and gangs as required to feed all devices as noted on plans
 - c. Provide brass GFCI style, gasketed, hinged cover plate with flathead-screw style means of securing cover in the closed position.
 - d. Knockouts: 3/4" or 1" Conduit hubs, one per side, per gang.
 - e. Provide shallow boxes where required by field installation conditions or as required by Structural Engineer.
 - f. Manufacturer:
 - 1) Steel City 640 series floor box, P-64-GFCI cover plate ; www.tnb.com/
8. Concrete Floors - Recessed Floor Boxes:
- a. 11-gauge steel housing, suitable for installation in poured concrete floor applications.
 - b. Cover shall have hinged access door with solid metal "U" handle and integrated cable pass thru window. Pass-thru window opens down into box to avoid tripping hazards.
 - c. Transformable box bottom (for eight gang configurations only) with fully configurable gang plate dividers, compartment dividers, and center dividers. Provide arrangement of interior compartments as required to accommodate all devices indicated on plans and to separate voltages.
 - d. Provide manufacturer's brackets as required to accommodate all power and low voltage devices within each floor box.
 - e. Provide optional mitered brass carpet edging for installations in carpeted areas.
 - f. For areas with concrete, wood, or tile floors, install box such that finished floor is flush with the top edge of the box cover. Provide shim kit to install top of box flush with top of finished floor.
 - g. Provide manufacturer's concrete pour pan as required for proper installation.
 - h. Manufacturer:
 - 1) FSR Inc. FL-500-P series floor box, with FL-500P-BLP-C U-Access tile and carpet cover ; www.fsrinc.com/

9. Exterior Floor Boxes:
 - a. Outdoor ground boxes shall have been examined and tested by Underwriters Laboratories Inc. to meet NEMA 6P and IP68 requirements to be safe to use even during inclement weather and bear the UL Listing Mark.
 - b. Outdoor ground boxes shall be designed to trap and maintain an air pocket to protect the devices, plugs and connections from water, snow, and ice. Boxes shall be constructed from UV rated chemical resistant materials. Boxes designed to ANSI/SCTE 77 with a Tier 5 rating to hold up to 5000 lbs of load. Boxes install flush to finished ground reducing tripping hazards. Box shall have a diving bell concept to maintain an air pocket and keep water away from connections. Box shall have an egress door that will auto-adjust to cable diameter and auto-lock in the closed position when no cables are exiting the box.
 - c. Provide quantity of enclosures as required to accommodate all devices noted on plans.
 - d. Provide manufacturer's brackets as required to accommodate all power and low voltage devices within each floor box.
 - e. Box covers shall come with pre-wired and installed electrical devices. Refer to plans for configuration of devices in each box.
 - 1) General: Single service 2-gang ground box manufactured from UV rated nonmetallic material. Box accepts up to two 1-1/4" trade size PVC conduit feeds. Boxes designed to be installed separately or ganged together for greater capacity and flexibility. Accepts optional cover assembly (see options below). Box assemblies include main box body, installation cap, and installation plate.
 - 2) 125V, 20A, 1P Devices: Assembly prewired with two (2) 20A L5-20R weather-resistant duplex receptacles. Cover assembly includes flange, cover, junction box, (2) 20A 5-20R receptacles, SOOW cord, wet location wire connectors, key, and mounting hardware.
 - 3) 125V, 30A, 1P Devices: Assembly prewired with one (1) 30A L5-30R 120V corrosion-resistant duplex receptacle. Cover assembly includes flange, cover, junction box, SOOW cord, L5-30R receptacle, wet location wire connectors, key, and mounting hardware.
 - 4) 250V, 30A, 2P Devices: Assembly prewired with one (1) 30A L6-30R 208V corrosion-resistant duplex receptacle. Cover assembly includes flange, cover, junction box, SOOW cord, L6-30R receptacle, wet location wire connectors, key, and mounting hardware.
 - 5) Low Voltage Devices: Assembly designed to accept up to 12 communication ports or eight (8) manufacturer's audio/visual devices. Cover assembly includes flange, cover, junction box, corrugated conduit assembly, (1) 12 port communication mounting plate, (1) 8 port manufacturer's audio/video mounting plate, key, and mounting hardware.
 - f. Manufacturer:
 - 1) Enclosure: Legrand XB814 series ; www.legrand.com/
 - 2) Interior: 125V, 20A, 1P Devices: Legrand XB814C520BK, 125V, 30A, 1P Devices: Legrand XB814CL530BK, 250V, 30A, 2P Devices: Legrand XB814CL630BK, and Low Voltage Devices: Legrand XB814CLVBK
10. Recessed Poke-Thrus: In-floor, round enclosure to provide access to power and data devices in a recessed enclosure such that plugs are not exposed when in-use.
 - a. Poke-thru assembly: Assembly shall consist of an insert and an activation cover.
 - b. Insert body shall recess the devices a minimum of 2-3/4 inches and have a polyester based backing enamel finished interior; ivory color. Furnish with necessary channels to provide complete separation of power and communication services. Provide quantity of compartments that allow for up to three (3) duplex receptacles that can be wired as a standard receptacle or isolated ground and/or twelve (12) communication ports and/or up to ten (10) AV devices.
 - c. Activation Cover shall be manufactured of die-cast aluminum alloy; finished in brass. Provide with two gaskets to go under the trim flange to maintain scrub water

- tightness. Provide cover with spring-loaded slides to allow cables to egress out of the unit and maintain as small an egress opening as possible.
- d. Provide activation unit with locations to mount communication connectors as required to support all devices shown on plans. Mount connectors using a mounting bracket capable of accepting data jack insert modules or discrete keystone connectors.
 - e. Manufacturers:
 - 1) Legrand Wiremold 6AT ; www.legrand.com/
11. Flush Poke-Thrus: In-floor, round enclosure to provide connections to hardwired modular furniture systems.
- a. Furniture Feed Poke-Thru Assembly consists of an insert and activation cover.
 - b. Insert body shall have the necessary channels to provide complete separation of power and communication services. There shall be one (1) 3/4-inch trade size channel for power and one (1) 1-1/2-inch trade size channel for communication cabling.
 - c. The activation cover shall provide two (2) conduit openings to feed modular furniture applications and provide a flush appearance. The activation cover trim flange shall be one-piece and be manufactured of die-cast aluminum alloy and be capable of being powder coated or plated. Coated finish is to be textured, two-stage epoxy paint in brass. The activation cover shall be 8-1/4 inches in diameter and shall be gasketed.
 - d. The activation cover insert shall provide one (1) 3/4-inch NPSM threaded opening for power and one (1) 1-1/2-inch NPSM threaded opening for communication to feed modular furniture workstations. Conduit closure plugs shall be provided for each unused opening.
 - e. Manufacturers:
 - 1) Legrand Wiremold 4FATC ; www.legrand.com/
- E. Boxes for Hazardous (Classified) Locations: Listed and labeled as complying with UL 1203 for the classification of the installed location.
1. Manufacturers:
 - a. Appleton, a brand of Emerson Electric Co: www.emerson.com/#sle.
 - b. Cooper Crouse-Hinds, a division of Eaton Corporation: www.cooperindustries.com/#sle.
 - c. Hubbell Incorporated; Killark Products: www.hubbell-killark.com/#sle.
- F. Underground Boxes/Enclosures:
1. Description: In-ground, open bottom boxes furnished with flush, non-skid covers with legend indicating type of service and stainless steel tamper resistant cover bolts.
 2. Size: As indicated on drawings.
 3. Depth: As required to extend below frost line to prevent frost upheaval, but not less than 12 inches.
 4. Provide logo on cover to indicate type of service. Covers shall read as follows for each system type:
 - a. Power Systems: "ELECTRICAL"
 - b. Site Lighting and/or Pole Lighting: "LIGHTING"
 - c. Fire Alarm Systems: "FIRE ALARM"
 - d. Other Low Voltage Systems: "COMMUNICATIONS"
 - e. Utility: Per utility company requirements
 5. Applications:
 - a. Sidewalks/paved areas 6'-0" wide and smaller and Landscaped Areas Subject Only to Occasional Nondeliberate Vehicular Traffic: Use polymer concrete enclosures, with minimum SCTE 77 Tier 8 load rating.
 - b. Parking Lots, Sidewalks/paved areas larger than 6'-0" wide, and in Areas Subject Only To Occasional Vehicular Traffic: Use reinforced concrete enclosures with galvanized steel checker plate lids, with HS20-44 rating.
 - c. Do not use polymer concrete enclosures in areas subject to deliberate vehicular traffic.

6. Polymer Concrete and Reinforced Concrete Underground Boxes/Enclosures: Comply with SCTE 77 and HS20-44.
 - a. Manufacturers:
 - 1) Oldcastle Precast, Inc: www.oldcastleprecast.com/#sle.
 - b. Combination fiberglass/polymer concrete boxes/enclosures are not acceptable. Use all-polymer concrete boxes/enclosures.

2.02 ACCESSORIES

- A. Flashing Panels for Exterior Wall Penetrations: Premanufactured components and accessories as required to preserve integrity of building envelope; suitable for boxes and facade materials to be installed.
 1. Manufacturers:
 - a. Quickflash Weatherproofing Products, Inc: www.quickflashproducts.com/#sle.

PART 3 EXECUTION

3.01 EXAMINATION

- A. Verify that field measurements are as indicated.
- B. Verify that mounting surfaces are ready to receive boxes.
- C. Verify that conditions are satisfactory for installation prior to starting work.

3.02 INSTALLATION

- A. Install products in accordance with manufacturer's instructions.
- B. Install boxes in accordance with NECA 1 (general workmanship) and, where applicable, NECA 130, including mounting heights specified in those standards where mounting heights are not indicated.
- C. Arrange equipment to provide minimum clearances in accordance with manufacturer's instructions and NFPA 70.
- D. Provide separate boxes for emergency power and normal power systems.
- E. Unless otherwise indicated, provide separate boxes for line voltage and low voltage systems.
- F. Flush-mount boxes in finished areas unless specifically indicated to be surface-mounted.
- G. Unless otherwise indicated, boxes may be surface-mounted where exposed conduits are indicated or permitted.
- H. Box Locations:
 1. Locate boxes to be accessible. Provide access panels in accordance with Section 08 31 00 as required where approved by the Architect.
 2. Unless dimensioned, box locations indicated are approximate.
 3. Locate boxes so that wall plates do not span different building finishes.
 4. Locate boxes so that wall plates do not cross masonry joints.
 5. Unless otherwise indicated, where multiple outlet boxes are installed at the same location at different mounting heights, install along a common vertical center line.
 6. Do not install flush-mounted boxes on opposite sides of walls back-to-back. Provide minimum 6 inches horizontal separation unless otherwise indicated.
 7. Acoustic-Rated Walls: Do not install flush-mounted boxes on opposite sides of walls back-to-back; provide minimum 24 inches horizontal separation.
 8. Fire Resistance Rated Walls: Install flush-mounted boxes such that the required fire resistance will not be reduced.
 - a. Do not install flush-mounted boxes on opposite sides of walls back-to-back; provide minimum 24 inches separation where wall is constructed with individual noncommunicating stud cavities or protect both boxes with listed putty pads.
 - b. Do not install flush-mounted boxes with area larger than 16 square inches or such that the total aggregate area of openings exceeds 100 square inches for any 100 square feet of wall area.

9. Locate junction and pull boxes as indicated, as required to facilitate installation of conductors, and to limit conduit length and/or number of bends between pulling points in accordance with Section 26 05 33.13.
10. Outlet boxes shall be installed at the locations and elevations shown on the drawings or specified herein. Make adjustments to locations as required by structural conditions and to suit coordination requirements of other trades.
11. Locate switch outlet boxes on the latch side of doorways unless otherwise indicated.
12. Locate junction and pull boxes in the following areas, unless otherwise indicated or approved by the Architect:
 13. Outlet boxes shall not be installed back to back nor shall through-wall boxes be permitted.
 14. For boxes mounted in exterior walls, make sure that there is insulation behind outlet boxes to prevent condensation in boxes.
 15. For outlets mounted above counters, benches or backsplashes, coordinate location and mounting heights with built-in units. Adjust mounting height with required location for equipment served.
 - a. Concealed above accessible suspended ceilings.
 - b. Within joists in areas with no ceiling.
 - c. Electrical rooms.
 - d. Mechanical equipment rooms.
- I. Box Supports:
 1. Secure and support boxes in accordance with NFPA 70 and Section 26 05 29 using suitable supports and methods approved by the authority having jurisdiction.
 2. Provide required seismic controls in accordance with Section 26 05 48.
 3. Provide independent support from building structure except for cast metal boxes (other than boxes used for fixture support) supported by threaded conduit connections in accordance with NFPA 70. Do not provide support from piping, ductwork, or other systems.
 4. Installation Above Suspended Ceilings: Do not provide support from ceiling grid or ceiling support system.
 5. Use far-side support to secure flush-mounted boxes supported from single stud in hollow stud walls. Repair or replace supports for boxes that permit excessive movement.
- J. Install boxes plumb and level.
- K. Flush-Mounted Boxes:
 1. Install boxes in noncombustible materials such as concrete, tile, gypsum, plaster, etc. so that front edge of box or associated raised cover is not set back from finished surface more than 1/4 inch or does not project beyond finished surface.
 2. Install boxes in combustible materials such as wood so that front edge of box or associated raised cover is flush with finished surface.
 3. Repair rough openings around boxes in noncombustible materials such as concrete, tile, gypsum, plaster, etc. so that there are no gaps or open spaces greater than 1/8 inch at the edge of the box.
- L. Install boxes as required to preserve insulation integrity.
- M. Metallic Floor Boxes: Install box level at the proper elevation to be flush with finished floor.
- N. Underground Boxes/Enclosures:
 1. Install enclosure on gravel base, minimum 6 inches deep.
 2. Flush-mount enclosures located in concrete or paved areas.
 3. Mount enclosures located in landscaped areas with top at 1 inch above finished grade.
 4. Install additional bracing inside enclosures in accordance with manufacturer's instructions to minimize box sidewall deflections during backfilling. Backfill with cover bolted in place.
- O. Install permanent barrier between ganged wiring devices when voltage between adjacent devices exceeds 300 V.
- P. Install firestopping to preserve fire resistance rating of partitions and other elements, using materials and methods specified in Section 07 84 00.

- Q. Close unused box openings.
- R. Install blank wall plates on junction boxes and on outlet boxes with no devices or equipment installed or designated for future use. Leave no unused openings in any box. Install close-up plugs as required to seal all openings and removed knockouts.
- S. Provide grounding and bonding in accordance with Section 26 05 26.
- T. Poke-Thrus
 - 1. Coordinate coring of all poke-thru locations, and/or locations for pre-drilled holes, with Structural Engineer prior to installation. Size of poke-thru core shall be per manufacturer requirements.

3.03 CLEANING

- 1. X-ray all pre- and post-tensioned slabs prior to core-drilling to ensure no tendons are damaged during installation. Notify Engineer of any conflicting locations.
- B. Exterior In-Grade Floor Boxes
 - 1. Examine conditions under which outdoor ground boxes are to be installed. Notify the Engineer in writing of conditions detrimental to proper completion of the work. Do not proceed with work until unsatisfactory conditions have been corrected.
 - 2. Strictly comply with manufacturer's installation instructions and recommendations. Coordinate installation with adjacent work to ensure proper clearances and to prevent electrical hazards.
 - 3. Boxes shall be located in approximate locations as shown on plans. Exact location shall be in well-drained areas, away from inlets and outfalls. Boxes shall not be located in low areas or in areas prone to accumulate standing water. Notify Engineer prior to rough-in and install of any potential water infiltration issues or concerns.
 - 4. Adjacent grade shall be within 1% of level.
 - 5. Provide a pre-installation call and/or site meeting with the manufacturer to discuss proper installation methodologies. Call shall be a minimum of ½ hour and shall cover the following:
 - a. Site specific issues
 - b. Requirements for preparation of box installation
 - c. Installation requirements
- C. Clean interior of boxes to remove dirt, debris, plaster and other foreign material.

3.04 PROTECTION

- A. Immediately after installation, protect boxes from entry of moisture and foreign material until ready for installation of conductors.

END OF SECTION

**SECTION 26 27 26
WIRING DEVICES****PART 1 GENERAL****1.01 SECTION INCLUDES**

- A. Wall switches.
- B. Receptacles.
- C. Wall plates.

1.02 RELATED REQUIREMENTS

- A. Section 26 05 33.16 - Boxes for Electrical Systems.

1.03 REFERENCE STANDARDS

- A. FS W-C-596 - Connector, Electrical, Power, General Specification for; 2014h, with Amendments (2017).
- B. FS W-S-896 - Switches, Toggle (Toggle and Lock), Flush Mounted (General Specification); 2014g, with Amendment (2017).
- C. NECA 1 - Standard for Good Workmanship in Electrical Construction; 2015.
- D. NECA 130 - Standard for Installing and Maintaining Wiring Devices; 2016.
- E. NEMA WD 1 - General Color Requirements for Wiring Devices; 1999 (Reaffirmed 2020).
- F. NEMA WD 6 - Wiring Devices - Dimensional Specifications; 2021.
- G. NFPA 70 - National Electrical Code; Most Recent Edition Adopted by Authority Having Jurisdiction, Including All Applicable Amendments and Supplements.
- H. UL 20 - General-Use Snap Switches; Current Edition, Including All Revisions.
- I. UL 498 - Attachment Plugs and Receptacles; Current Edition, Including All Revisions.
- J. UL 514D - Cover Plates for Flush-Mounted Wiring Devices; Current Edition, Including All Revisions.
- K. UL 943 - Ground-Fault Circuit-Interrupters; Current Edition, Including All Revisions.
- L. UL 1310 - Class 2 Power Units; Current Edition, Including All Revisions.

1.04 ADMINISTRATIVE REQUIREMENTS

- A. Coordination:
 - 1. Coordinate the placement of outlet boxes with millwork, furniture, equipment, etc. installed under other sections or by others.
 - 2. Coordinate wiring device ratings and configurations with the electrical requirements of actual equipment to be installed.
 - 3. Coordinate the placement of outlet boxes for wall switches with actual installed door swings. Switches shall be located on the strike side of the door, unless otherwise noted, and shall not be obstructed by the door when it is in the open position.
 - 4. Coordinate the installation and preparation of uneven surfaces, such as split face block, to provide suitable surface for installation of wiring devices.
 - 5. Notify Architect of any conflicts or deviations from Contract Documents to obtain direction prior to proceeding with work.
- B. Sequencing:
 - 1. Do not install wiring devices until final surface finishes and painting are complete.

1.05 SUBMITTALS

- A. Product Data: Provide manufacturer's catalog information showing dimensions, colors, and configurations.
- B. Manufacturer's Installation Instructions: Indicate application conditions and limitations of use stipulated by product testing agency. Include instructions for storage, handling, protection, examination, preparation, and installation of product.

- C. Operation and Maintenance Data:
 - 1. GFCI Receptacles: Include information on status indicators.
- D. Project Record Documents: Record actual installed locations of wiring devices.
- E. Maintenance Materials: Furnish the following for Owner's use in maintenance of project.
 - 1. Screwdrivers for Tamper-Resistant Screws: Two for each type of screw.
 - 2. Extra Wall Plates: One of each style, size, and finish.

1.06 QUALITY ASSURANCE

- A. Comply with requirements of NFPA 70.
- B. Manufacturer Qualifications: Company specializing in manufacturing the products specified in this section with minimum three years documented experience.
- C. Products: Listed, classified, and labeled as suitable for the purpose intended.
- D. Product Listing Organization Qualifications: An organization recognized by OSHA as a Nationally Recognized Testing Laboratory (NRTL) and acceptable to authorities having jurisdiction.

1.07 DELIVERY, STORAGE, AND PROTECTION

- A. Store in a clean, dry space in original manufacturer's packaging until ready for installation.

PART 2 PRODUCTS

2.01 WIRING DEVICE APPLICATIONS

- A. Provide wiring devices suitable for intended use and with ratings adequate for load served.
- B. For single receptacles installed on an individual branch circuit, provide receptacle with ampere rating not less than that of the branch circuit.
- C. Provide weather resistant GFCI receptacles with specified weatherproof covers for receptacles installed outdoors or in damp or wet locations.
- D. Provide tamper resistant receptacles for receptacles installed in dwelling units, kindergarten classrooms, and daycare facilities.
- E. Provide GFCI protection for receptacles installed within 6 feet of sinks.
- F. Provide GFCI protection for receptacles installed in kitchens.
- G. Provide GFCI protection for receptacles serving electric drinking fountains.
- H. Unless noted otherwise, do not use combination switch/receptacle devices.

2.02 WIRING DEVICE FINISHES

- A. Provide wiring device finishes as described below unless otherwise indicated.
- B. Wiring Devices Installed in Finished Spaces: White with white nylon wall plate.
- C. Wiring Devices Installed in Finished Spaces : White with stainless steel wall plate.
- D. Wiring Devices Installed in Unfinished Spaces: White with galvanized steel wall plate.
- E. Wiring Devices Installed in Wet or Damp Locations: White with specified weatherproof cover.

2.03 WALL SWITCHES

- A. Manufacturers:
 - 1. Hubbell Incorporated: www.hubbell.com/#sle.
 - 2. Leviton Manufacturing Company, Inc: www.leviton.com/#sle.
 - 3. Pass & Seymour, a brand of Legrand North America, Inc: www.legrand.us/#sle.
- B. Wall Switches - General Requirements: AC only, quiet operating, general-use snap switches with silver alloy contacts, complying with NEMA WD 1 and NEMA WD 6, and listed as complying with UL 20 and where applicable, FS W-S-896; types as indicated on the drawings.
 - 1. Wiring Provisions: Terminal screws for side wiring and screw actuated binding clamp for back wiring with separate ground terminal screw.

- C. Standard Wall Switches: Industrial specification grade, 20 A, 120/277 V with standard toggle type switch actuator and maintained contacts; single pole single throw, double pole single throw, three way, or four way as indicated on the drawings.

2.04 RECEPTACLES

- A. Manufacturers:
 - 1. Hubbell Incorporated: www.hubbell.com/#sle.
 - 2. Leviton Manufacturing Company, Inc: www.leviton.com/#sle.
 - 3. Pass & Seymour, a brand of Legrand North America, Inc: www.legrand.us/#sle.
- B. Receptacles - General Requirements: Self-grounding, complying with NEMA WD 1 and NEMA WD 6, and listed as complying with UL 498, and where applicable, FS W-C-596; types as indicated on the drawings.
 - 1. Wiring Provisions: Terminal screws for side wiring or screw actuated binding clamp for back wiring with separate ground terminal screw.
 - 2. NEMA configurations specified are according to NEMA WD 6.
- C. Convenience Receptacles:
 - 1. Standard Convenience Receptacles: Industrial specification grade, 20A, 125V, NEMA 5-20R; single or duplex as indicated on the drawings.
 - 2. Automatically Controlled Convenience Receptacles: Industrial specification grade, 20A, 125V, NEMA 5-20R; controlled receptacle marking on device face per NFPA 70; single or duplex as indicated on the drawings.
 - 3. Weather Resistant Convenience Receptacles: Industrial specification grade, 20A, 125V, NEMA 5-20R, listed and labeled as weather resistant type complying with UL 498 Supplement SD suitable for installation in damp or wet locations; single or duplex as indicated on the drawings.
 - 4. Tamper Resistant Convenience Receptacles: Industrial specification grade, 20A, 125V, NEMA 5-20R, listed and labeled as tamper resistant type; single or duplex as indicated on the drawings.
- D. GFCI Receptacles:
 - 1. GFCI Receptacles - General Requirements: Self-testing, with feed-through protection and light to indicate ground fault tripped condition and loss of protection; listed as complying with UL 943, class A.
 - a. Provide test and reset buttons of same color as device.
 - 2. Standard GFCI Receptacles: Industrial specification grade, duplex, 20A, 125V, NEMA 5-20R, rectangular decorator style.
 - 3. Combination AFCI and GFCI Receptacles: Industrial specification grade, duplex, 20A, 125V, NEMA 5-20R, rectangular decorator style, listed and labeled as a combination GFCI/AFCI protective device and complying with UL 498, UL 943, and UL 1699A.
 - 4. Weather Resistant GFCI Receptacles: Industrial specification grade, duplex, 20A, 125V, NEMA 5-20R, rectangular decorator style, listed and labeled as weather resistant type complying with UL 498 Supplement SD suitable for installation in damp or wet locations.
 - 5. Tamper Resistant GFCI Receptacles: Industrial specification grade, duplex, 20A, 125V, NEMA 5-20R, rectangular decorator style, listed and labeled as tamper resistant type.
- E. USB Charging Devices:
 - 1. USB Charging Devices - General Requirements: Listed as complying with UL 1310.
 - a. Charging Capacity - Two-Port Devices: 2.1 A, minimum.
 - b. Charging Capacity - Four-Port Devices: 4.2 A, minimum.
 - 2. USB Charging/Tamper Resistant Receptacle Combination Devices: Two-port (One Type-A and One Type-C) USB charging device and receptacle, commercial specification grade, duplex, 20A, 125V, NEMA 5-20R, listed and labeled as tamper resistant type; rectangular decorator style.
 - 3. USB Charging Noncombination Devices: Four-port (Two Type-A and Two Type-C); rectangular decorator style.

2.05 WALL PLATES

- A. Manufacturers:
 - 1. Hubbell Incorporated: www.hubbell-wiring.com/#sle.
 - 2. Leviton Manufacturing Company, Inc: www.leviton.com/#sle.
 - 3. Pass & Seymour, a brand of Legrand North America, Inc: www.legrand.us/#sle.
- B. Wall Plates: Comply with UL 514D.
 - 1. Configuration: One piece cover as required for quantity and types of corresponding wiring devices.
 - 2. Size: Standard.
 - 3. Screws: Metal with slotted heads finished to match wall plate finish.
- C. Nylon Wall Plates: Smooth finish, high-impact thermoplastic.
- D. Stainless Steel Wall Plates: Brushed satin finish, Type 302 stainless steel.
- E. Galvanized Steel Wall Plates: Rounded corners and edges, with corrosion resistant screws.
- F. Premarked Wall Plates: Factory labeled as indicated; hot stamped for nylon wall plates and engraved for metal wall plates.
- G. Weatherproof Covers for Wet or Damp Locations: Gasketed, cast aluminum, with hinged lockable cover and corrosion-resistant screws; listed as suitable for use in wet locations while in use with attachment plugs connected and identified as extra-duty type.

PART 3 EXECUTION**3.01 EXAMINATION**

- A. Verify that field measurements are as indicated.
- B. Verify that outlet boxes are installed in proper locations and at proper mounting heights and are properly sized to accommodate devices and conductors in accordance with NFPA 70.
- C. Verify that wall openings are neatly cut and will be completely covered by wall plates.
- D. Verify that final surface finishes are complete, including painting.
- E. Verify that branch circuit wiring installation is completed, tested, and ready for connection to wiring devices.
- F. Verify that conditions are satisfactory for installation prior to starting work.

3.02 PREPARATION

- A. Provide extension rings to bring outlet boxes flush with finished surface.
- B. Clean dirt, debris, plaster, and other foreign materials from outlet boxes.

3.03 INSTALLATION

- A. Perform work in accordance with NECA 1 (general workmanship) and, where applicable, NECA 130, including mounting heights specified in those standards unless otherwise indicated.
- B. Coordinate locations of outlet boxes provided under Section 26 05 33.16 as required for installation of wiring devices provided under this section.
 - 1. Orient outlet boxes for vertical installation of wiring devices unless otherwise indicated.
 - 2. Where multiple receptacles, wall switches, or wall dimmers are installed at the same location and at the same mounting height, gang devices together under a common wall plate.
 - 3. Locate wall switches on strike side of door with edge of wall plate 3 inches from edge of door frame. Where locations are indicated otherwise, notify Architect to obtain direction prior to proceeding with work.
 - 4. Locate receptacles for electric drinking fountains concealed behind drinking fountain according to manufacturer's instructions.
- C. Install wiring devices in accordance with manufacturer's instructions.
- D. Install permanent barrier between ganged wiring devices when voltage between adjacent devices exceeds 300 V.

- E. Where required, connect wiring devices using pigtails not less than 6 inches long. Do not connect more than one conductor to wiring device terminals.
- F. Connect wiring devices by wrapping conductor clockwise 3/4 turn around screw terminal and tightening to proper torque specified by the manufacturer. Where present, do not use push-in pressure terminals that do not rely on screw-actuated binding.
- G. Unless otherwise indicated, connect wiring device grounding terminal to branch circuit equipment grounding conductor and to outlet box with bonding jumper.
- H. Provide GFCI receptacles with integral GFCI protection at each location indicated. Do not use feed-through wiring to protect downstream devices.
- I. Where split-wired duplex receptacles are indicated, remove tabs connecting top and bottom receptacles.
- J. Install wiring devices plumb and level with mounting yoke held rigidly in place.
- K. Install wall switches with OFF position down.
- L. Install vertically mounted receptacles with grounding pole on top and horizontally mounted receptacles with grounding pole on left.
- M. Install wall plates to fit completely flush to wall with no gaps and rough opening completely covered without strain on wall plate. Repair or reinstall improperly installed outlet boxes or improperly sized rough openings. Do not use oversized wall plates in lieu of meeting this requirement.
- N. Install blank wall plates on junction boxes and on outlet boxes with no wiring devices installed or designated for future use.

3.04 FIELD QUALITY CONTROL

- A. Inspect each wiring device for damage and defects.
- B. Operate each wall switch, wall dimmer, and fan speed controller with circuit energized to verify proper operation.
- C. Test each receptacle to verify operation and proper polarity.
- D. Test each GFCI receptacle for proper tripping operation according to manufacturer's instructions.
- E. Correct wiring deficiencies and replace damaged or defective wiring devices.

3.05 ADJUSTING

- A. Adjust devices and wall plates to be flush and level.

3.06 CLEANING

- A. Clean exposed surfaces to remove dirt, paint, or other foreign material and restore to match original factory finish.

END OF SECTION

SECTION 31100

SITE CLEARING

PART 1 - GENERAL

1.1 SECTION INCLUDES

- A. Removal of existing trees and vegetation
- B. Clearing vegetation, debris, trash and other materials within limits indicated
- C. Grubbing of vegetation within limits indicated
- D. Stripping of topsoil within limits indicated
- E. Removing above-grade site improvements within limits indicated
- F. Disconnecting, capping or sealing, and abandoning site utilities in place
- G. Disconnecting, capping or sealing, and removing site utilities
- H. Disposing of objectionable material

1.2 RELATED SECTIONS

- A. Section 31 20 00, Earth Moving
- B. Section 32 13 00, Rigid Paving

1.3 RELATED DOCUMENTS

- A. Geotechnical Report: Geotechnical Evaluation, Jollyman Park All-Inclusive Playground, Ninyo & Moore Geotechnical & Environmental Sciences Consultants, February 18th 2022.
- B. ANSI A300: Industry Standards for Tree Care Practices
- C. Applicable Publications
 - 1. "Trees and Building Sites," official publication of the International Society of Arboriculture.
 - 2. "Arboriculture," the care of trees and shrubs by Dr. Richard Harris.

1.4 DEFINITIONS

- A. ANSI: American National Standards Institute

- B. CAL-OSHA: California Occupational Safety and Health Administration
- C. Topsoil: Natural or cultivated surface-soil layer containing organic matter and sand, silt, and clay particles; friable, pervious, and black or a darker shade of brown, gray, or red than underlying subsoil; reasonably free of subsoil, clay lumps, gravel, and other objects more than 2 inches in diameter; and free of weeds, roots, and other deleterious materials.

1.5 SUBMITTALS

- A. Photographs or videotape, sufficiently detailed, of existing conditions of trees and plantings, adjoining construction, and site improvements that might be misconstrued as damage caused by site clearing.

1.6 QUALITY ASSURANCE

- A. Do not remove or prune trees without first securing a permit from the appropriate agency.
- B. Prune to the standards of the International Society of Arborists and to ANSI A300.

1.7 PROJECT CONDITIONS

- A. Except for materials indicated to be stockpiled or to remain the City's Representative's property, cleared materials are the Contractor's property. Remove cleared materials from site and dispose of in lawful manner.
- B. Salvageable Improvements: Carefully remove items indicated to be salvaged and store where indicated on plans or where designated by the City's Representative. Avoid damaging materials designated for salvage.
- C. Unidentified Materials;
 - 1. If unidentified materials are discovered, including hazardous materials that will require additional removal other than is required by the Contract Documents, immediately report the discovery to the City's Representative.
 - 2. If necessary, the City's Representative will arrange for any testing or analysis of the discovered materials and will provide instructions regarding the removal and disposal of the unidentified materials.

PART 2 - PRODUCTS

2.1 SOIL MATERIALS

- A. Backfill excavations resulting from demolition operations with on-site or import materials conforming to engineered fill defined in Section 31 20 00, Earth Moving.

PART 3 - EXECUTION

3.1 PREPARATION

- A. Protect and maintain benchmarks and survey control points during construction.
- B. Locate and clearly flag trees and vegetation to remain or to be relocated.
- C. Protect existing site improvements to remain during construction.

3.2 TREE REMOVAL

- A. Remove trees designated for removal prior to the construction of new improvements in the vicinity:
 - 1. When demolishing trees indicated to be removed within areas for new pavement or hardscape, remove tree, stump to a depth of two (2) feet below finish grade, and all roots located in the top twelve (12) inches of soil. Remove wood chips created from grinding process down to remaining stump then refill void and re-compact to 80% relative compaction. Use import soil as indicated in specifications for this purpose. Import soil and compaction in future paved areas shall be in accordance with Section 32 13 00, Rigid Paving.
 - 2. When demolishing trees indicated to be removed within new landscaped areas, removal shall be done in one of the following ways:
 - 3. For trees located in accessible areas, remove tree and grind stump to four (4) inches below finish grade. Backfill the void and re-compact to 80% relative compaction. Use import soil as indicated in specifications for this purpose. Do not remove existing roots.
 - 4. For trees located in inaccessible areas, cut stump flush with finish grade, and cover with 3 inches of bark mulch. Do not grind the stump and do not remove existing roots.
- B. Perform tree removal work in a safe and proper manner, adhering to CAL-OSHA tree work protection standards and ANSI A300 Standards.
- C. All trees to be demolished shall be removed in such a way as to not damage branches, trunks, or root systems of adjacent trees.

3.3 RESTORATION

- A. Restore damaged improvements to their original condition, as acceptable to the City's Representative.
- B. Repair or replace trees and vegetation indicated to remain that are damaged by construction operations, as directed by the City's Representative.
 - 1. Employ a qualified arborist, licensed in jurisdiction where the Project is located, to submit details of proposed repairs and to repair damage to trees and shrubs.
 - 2. Replace trees that cannot be repaired and restored to full-growth status, as determined by the City's Representative.

3.4 UTILITIES

- A. Locate, identify, disconnect, and seal or cap off utilities indicated to be removed or abandoned.
- B. Arrange to shut off indicated utilities with utility companies or verify that utilities have been shut off.
- C. Existing Utilities: Do not interrupt utilities serving facilities occupied by City's Representative or others unless authorized in writing by the City's representative, and then only after arranging to provide temporary utility services according to requirements indicated.
- D. Coordinate utility interruptions with utility company affected.
- E. Do not proceed with utility interruptions without the permission of the City's Representative and utility company affected. Notify City's Representative and utility company affected two working days prior to utility interruptions.
- F. Excavate and remove underground utilities that are indicated to be removed.
- G. Fill abandoned piping with cement slurry.
- H. Securely close ends of abandoned piping with tight fitting plug or cement slurry minimum 6 inches thick.

3.5 CLEARING AND GRUBBING

- A. Areas to be graded shall be cleared of existing vegetation, rubbish, existing structures, and debris.
- B. Remove obstructions, shrubs, grass, and other vegetation to permit installation of new construction. Removal includes digging out stumps and obstructions and grubbing roots.
- C. Do not remove trees, shrubs, and other vegetation indicated to remain or to be relocated.
- D. Use only hand methods for grubbing within drip line of remaining trees.

3.6 SITE STRIPPING

- A. Strippings and spoils shall be disposed at an off-site location, per geotechnical recommendations.
- B. Remove vegetation before stripping soil.

- C. Surface soils that contain organic matter should be stripped. In general, the depth of required stripping will be relatively shallow (i.e. less than 2 inches); deeper stripping and grubbing may be required to remove isolated concentrations of organic matter or roots.
- D. Remove trash, debris, weeds, roots, and other waste materials.
- E. Stockpile soil materials designated to remain on site at a location approved by the City's Representative at a location away from edge of excavations without intermixing with subsoil. Grade and shape stockpiles to drain surface water. Cover to prevent windblown dust.
- F. Do not stockpile soil within drip line of remaining trees.

3.7 SITE IMPROVEMENTS

- A. Remove existing above- and below-grade improvements as indicated and as necessary to facilitate new construction.

3.8 BACKFILL

- A. Place and compact material in excavations and depressions remaining after site clearing in accordance with Section 31 20 00, Earth Moving.

3.9 DISPOSAL

- A. Remove surplus soil material, unsuitable soil, obstructions, demolished materials, and waste materials, including trash and debris, and legally dispose of them off the City's property.
- B. Fulfill GreenHalo requirements per the City of Cupertino "Development and Construction Guidelines".

END OF SECTION

SECTION 312000

EARTH MOVING

PART 1 - GENERAL

1.1 SECTION INCLUDES

- A. Excavation and/or embankment from existing ground to subgrade, including soil sterilant, for roadways, driveways, parking areas, building pads, walks, paths, or trails and any other site improvements called for on the Plans.

1.2 SECTION EXCLUDES

- A. Earthwork related to underground utility installation shall be performed in accordance with Sections 31 21 00, Utility Trenching and Backfill.

1.3 RELATED SECTIONS

- A. Refer to City of Cupertino Project Manual
- B. Section 01 57 13, Temporary Erosion and Sediment Control
- C. Section 31 10 00, Site Clearing

1.4 RELATED DOCUMENTS

- A. Geotechnical Report: Geotechnical Evaluation, Jollyman Park All-Inclusive Playground, Ninyo & Moore Geotechnical & Environmental Sciences Consultants, February 18th 2022.
- B. ASTM
 - 1. D1557, Test Method for Laboratory Compaction Characteristics of Soil Using Modified Effort
 - 2. D1586, Method for Penetration Tests and Split-Barrel Sampling of Soils
 - 3. D2487, Classification of Soils for Engineering Purposes
 - 4. D3740, Practice for Evaluation of Agencies Engaged in Testing and/or Inspection of Soil and Rock as Used in Engineering Design and Construction.
 - 5. D4318. Test Method for Liquid Limit, Plastic Limit and Plasticity Index of Soils
 - 6. E329, Specification for Minimum Requirements for Agencies Engaged in the Testing and/or Inspection of Materials Used in Construction
 - 7. E548, Guide for General Criteria Used for Evaluating Laboratory Competence
- C. California Building Code, California Code of Regulations, Title 24, Part 2, Chapter 18, Soils and Foundations, and Chapter 33, Safeguards During Construction
- D. Caltrans Standard Specifications, 2015
 - 1. Section 17, General
 - 2. Section 19, Earthwork
- E. CAL/OSHA, Title 8.

1.5 DEFINITIONS

- A. Borrow: Approved soil material imported from off-site for use as Structural Fill or Backfill.
- B. Excavation: Removal of material encountered above subgrade elevations.
 - 1. Authorized Over-Excavation: Excavation below subgrade elevations or beyond indicated horizontal dimensions as shown on plans or authorized by the Geotechnical Engineer.
 - 2. Unauthorized Over-Excavation: Excavation below subgrade elevations or beyond indicated horizontal dimensions without authorization by the Geotechnical Engineer. Unauthorized excavation shall be without additional compensation.
- C. Geotechnical Testing Agency: An independent testing agency qualified according to ASTM E329 to conduct soil materials and rock definition testing, as documented according to ASTM D3740 and ASTM E548.
- D. Structural Backfill: Soil materials approved by the Geotechnical Engineer and used to fill excavations resulting from removal of existing below grade facilities, including trees.
- E. Structural Fill: Soil materials approved by the Geotechnical Engineer and used to raise existing grades.
- F. Rock: Rock material in beds, ledges, unstratified masses, and conglomerate deposits and boulders of rock material $\frac{3}{4}$ cubic yards or more in volume that when tested by an independent geotechnical testing agency, according to ASTM D1586, exceeds a standard penetration resistance of 100 blows/2 inches.
- G. Structures: Buildings, footings, foundations, retaining walls, slabs, tanks, curbs, mechanical and electrical appurtenances, or other man-made stationary features constructed above or below grade.
- H. Subgrade: Surface or elevation remaining after completing excavation, or top surface of a fill or backfill immediately below subbase, base or topsoil materials.
- I. Topsoil: Natural or cultivated surface-soil layer containing organic matter and sand, silt, and clay particles; friable, pervious, and black or a darker shade of brown, gray, or red than underlying subsoil; reasonably free of subsoil, clay lumps, gravel, and other objects more than 2 inches in diameter; and free of weeds, roots, and other deleterious materials.
- J. Unsuitable Material: Any soil material that is not suitable for a specific use on the Project. The Geotechnical Engineer will determine if a soil material is unsuitable.
- K. Relative Compaction: In-place dry density of soil expressed as percentage of maximum dry density of same materials, as determined by laboratory test procedure ASTM D1557.
- L. Utilities: onsite underground pipes, conduits, ducts and cables.

1.6 SUBMITTALS

- A. Follow submittal procedure outlined in Section 01 10 00, Supplemental General Requirements.

- B. Samples:
 - 1. If required by the Geotechnical Engineer, provide 20 pound samples, sealed in airtight containers, tagged with source locations and suppliers of each proposed soil material from on-site or borrow sources, 72 hours prior to use. Do not import materials to the Project without written approval of the Geotechnical Engineer.
 - 2. Provide materials from same source throughout work. Change of source requires approval of the Geotechnical Engineer.
- C. Material Test Reports: Provide, from a qualified testing agency, the following test results showing compliance with the project requirements.
- D. Classification according to ASTM D2487 of each onsite or borrow soil material proposed for fill and backfill.
 - 1. Laboratory compaction curve in conformance with ASTM D1557 for each onsite or borrow soil material proposed for fill and backfill.

1.7 QUALITY ASSURANCE

- A. Provide an independent testing agency qualified according to ASTM E329 to conduct soil materials and rock definition testing, as documented according to ASTM D3740 and ASTM E548.
- B. Conform all work and materials to the recommendations or requirements of the Geotechnical Report and meet the approval of the Geotechnical Engineer.
- C. Conform all work in accordance with Caltrans Standard Specification Section 17, General and Section 19, Earthwork.
- D. Percentage of compaction specified shall be the minimum acceptable. The percentage represents the ratio of the dry density of the compacted material to the maximum dry density of the material as determined by the procedure set forth in ASTM D1557.
- E. Perform excavation, filling, compaction and related earthwork under the observation of the Geotechnical Engineer. Materials placed without approval of the Geotechnical Engineer will be presumed to be defective and, at the discretion of the Geotechnical Engineer, shall be removed and replaced at no cost to the City's Representative. Notify the Geotechnical Engineer at least 24 hours prior to commencement of earthwork and at least 48 hours prior to testing.
- F. The Geotechnical Engineer will perform observations and tests required to enable him to form an opinion of the acceptability of the Project earthwork. Correct earthwork that, in the opinion of the Geotechnical Engineer, does not meet the requirements of these Technical Specifications and the Geotechnical Report.
- G. Upon completion of the construction work, certify that all compacted fills and foundations are in place at the correct locations, and have been constructed in accordance with sound construction practice. In addition, certify that the materials used are of the types, quality and quantity required by these Technical Specifications and the Geotechnical Report. The Contractor shall be responsible for the stability of all fills and backfills constructed by his forces and shall replace portions that in the opinion of the Geotechnical Engineer have been displaced or are otherwise unsatisfactory due to the Contractor's operations.
- H. Finish subgrade tolerance at completion of grading:

1. Building and paved areas: ± 0.05 feet
2. Other areas: ± 0.10 feet

1.8 PROJECT CONDITIONS

- A. Promptly notify the City's Representative of surface or subsurface conditions differing from those disclosed in the Geotechnical Report. First notify the City's Representative verbally to permit verification and extent of condition and then in writing. No claim for conditions differing from those anticipated in the Contract Documents and disclosed in the Geotechnical Report will be allowed unless the Contractor has notified the City's Representative in writing of differing conditions prior to the Contractor starting work on affected items.
- B. Protect open excavations, trenches, and the like with fences, covers and railings to maintain safe pedestrian and vehicular traffic passage.
- C. Prevent erosion of freshly-graded areas during construction and until such time as permanent drainage and erosion control measures have been installed in accordance with Section 01 50 50, Erosion Control.
- D. Temporarily stock-pile fill material in an orderly and safe manner and in a location approved by the City's Representative.
- E. Environmental Requirements: When unfavorable weather conditions necessitate interrupting earthwork operation, areas shall be prepared by compaction of surface and grading to avoid collection of water. Provide adequate temporary drainage to prevent erosion. After interruption, compaction specified in last layer shall be re-established before resuming work.

PART 2 - PRODUCTS

2.1 SOIL MATERIALS

- A. General: On-site soils are considered suitable for use as fill provided the materials are placed in accordance with Geotechnical Recommendations. Highly expansive soils shall not be used as select structural fill, or used as backfill for trenches located within hardscape areas.
- B. Imported fill soils, if required, should be predominantly granular in nature, and should be free of organics, debris, or rocks over 3 inches in size, and shall be approved by the Geotechnical Engineer before importing to the site. Imported non-expansive soils shall have a Plasticity Index less than 15 as determined by ASTM D4318, an R-value of at least 20, and fines content between 15 and 65 percent. Import fill shall be considered non-hazardous per Department of Toxic Substances Control guidelines (DTSC, 2017) and non-corrosive per Caltrans Corrosion Guidelines (Caltrans, 2015).

2.2 SOIL STERILANT

- A. Commercial chemical for weed control, registered by EPA. Provide granular, liquid or wet-able powder form.

PART 3 - EXECUTION

3.1 GENERAL

- A. Perform work in accordance with Caltrans Standard Specification Section 19, Earthwork, as modified by the Contract Documents.
- B. Placement and compaction of material by flooding, ponding, or jetting will not be permitted.
- C. The use of explosives will not be permitted.
- D. Grading and earthwork operations shall be observed and tested by a representative of the Geotechnical Engineer for conformance with the project plans/specifications and the geotechnical recommendations. This work includes site preparation, selection of satisfactory materials, and placement and compaction of the subgrades and fills. Sufficient notification prior to commencement of earthwork is essential to make certain that the work will be properly observed.

3.2 CONTROL OF WATER AND DEWATERING

- A. Prevent surface water and ground water from entering excavations, from ponding on prepared subgrades, and from flooding the site and surrounding area. Provide dewatering equipment necessary to drain and keep excavations and site free from water.
- B. Dewater during backfilling operation so that groundwater is maintained a least 1 foot below level of compaction effort.
- C. Obtain the Geotechnical Engineer's approval for proposed control of water and dewatering methods.
- D. Protect subgrades from softening, undermining, washout and damage by rain or water accumulation.
- E. Reroute surface water runoff away from excavated areas. Do not allow water to accumulate in excavations.
- F. Maintain dewatering system in place until dewatering is no longer required.

3.3 WET WEATHER CONDITIONS

- A. Do not prepare subgrade, place or compact soil materials if subgrade or materials are above optimum moisture content.

- B. If the Geotechnical Engineer allows work to continue during wet weather conditions, conform to supplemental recommendations provided by the Geotechnical Engineer.

3.4 BRACING AND SHORING

- A. Conform to California and Federal OSHA requirements.
- B. Place and maintain such bracing and shoring as may be required to support the sides of the excavations for the proper protection of workmen; to facilitate the work; to prevent damage to the facility being constructed; and to prevent damage to adjacent structures or facilities. Remove all bracing and shoring upon completion of the work.
- C. Be solely responsible for all bracing and shoring and, if requested by the City's Representative, submit details and calculations to the City's Representative. The City's Representative may forward the submittal to the Geotechnical Engineer, the Consulting Engineer and/or the California Division of Industrial Safety for their review. The Contractor's submittal shall include the basic design, assumed soils conditions and estimation of forces to be resisted, together with plans and specifications of the materials and methods to be used, and shall be prepared by a civil engineer or structural engineer registered in California. No excavations related to the proposed facility shall precede a response to the submittal by the City's Representative.
- D. Be solely responsible for installing and extracting the sheathing in a manner which will not disturb the position or operation of the facility being constructed or adjacent utilities and facilities.

3.5 EXCAVATION

- A. Excavate earth and rock to lines and grades shown on plans and to the neat dimensions indicated on the plans, required herein or as required to satisfactorily compact backfill.
- B. Remove and dispose of large rocks, pieces of concrete and other obstructions encountered during excavation.
- C. Excavation through buried concrete and other unknown obstructions will require specialized techniques for demolition and removal.
- D. Where forming is required, excavate only as much material as necessary to permit placing and removing forms.
- E. Provide supports, shoring and sheet piles required to support the sides of excavations or for protection of adjacent existing improvements.

3.6 GRADING

- A. Uniformly grade the Project to the elevations shown on plans
- B. Finish ditches, gutters and swales to the sections, lines and grades indicated and to permit proper surface drainage.

- C. Round tops and bottoms of slopes as indicated or to blend with existing contours.

3.7 SUBGRADE PREPARATION

- A. Subgrade Preparation: Prior to backfilling depressions created by the removal of old foundations and utility lines, scarify the bottom of the excavation to an approximate depth of 8 inches and uniformly moisture condition the scarified surfaces to a moisture content that is at least 2 percent over optimum. Compact the scarified surfaces to a minimum of 90 percent relative compaction at above optimum moisture content.
- B. Over-excavate any remaining soft (pumping) areas down to firm soil and backfill the area.
- C. Subgrade shall be maintained in a moist, but not wet, condition by periodically sprinkling water prior to the placement of additional fill or installation of roads. Subgrade that has been permitted to dry out and loosen or develop desiccation cracking should be scarified, moisture conditioned, and re-compacted as recommended above.
- D. Install underground utilities and service connections prior to final preparation of subgrade and placement of base materials for final surface facilities. Extend services so that final surface facilities are not disturbed when service connections are made.
- E. Prepare subgrades under the structural section of paved areas, curbs, gutters, walks, structures, other surface facilities and areas to receive structural fill.
- F. Protect utilities from damage during compaction of subgrades and until placement of final pavements or other surface facilities.
- G. Obtain the Geotechnical Engineer's approval of subgrades prior to placing pavement structural section.

3.8 KEYWAYS AND BENCHES

- A. Provide keyways as indicated for fill slopes steeper than 6 horizontal to 1 vertical. Extend keyway 5 feet minimum into competent, undisturbed soil or 3 feet minimum into competent, undisturbed rock as directed by the Geotechnical Engineer.
- B. Place subsurface drains in bottom of keyway in accordance with Section 33 46 00, Bioretention Subdrainage.
- C. Bench subgrade as indicated above toe of fill.
- D. Place subsurface drains at benches every 20 vertical feet or as directed by the Geotechnical Engineer.

3.9 LOT FINISH GRADING

- A. Blade finish lots to lines and grades indicated.

3.10 FILL PLACEMENT AND COMPACTION

- A. Place fill in uniformly moisture conditioned and compacted lifts not exceeding 8 inches in loose thickness. Each lift should be thoroughly moisture conditioned and compacted to 90 percent before successive fill layers are placed.
- B. In order to achieve satisfactory compaction in the subgrade and fill soils, it may be necessary to adjust the soil moisture content at the time of soil compaction per geotechnical recommendations. This may require that water be added and thoroughly mixed into any soils which are too dry or that scarification and aeration be performed in any soils which are too wet.
- C. Obtain the Geotechnical Engineer's approval of surface to receive structural fill prior to placement of structural fill material.
- D. Place structural fill on prepared subgrade.
- E. Do not drop fill on structures. Do not backfill around, against or upon concrete or masonry structures until structure has attained sufficient strength to withstand loads imposed and the horizontal structural system had been installed.
- F. Do not compact by ponding, flooding or jetting.
- G. Perform compaction using rollers, pneumatic or vibratory compactors or other equipment and mechanical methods approved by the Geotechnical Engineer.
- H. Compaction requirements (unless specified otherwise by the Geotechnical Engineer):
 - 1. Compact structural fills less than 5 feet thick to 90 percent compaction.
 - 2. Compact structural fill 5 feet thick or greater to 95 percent compaction.
 - 3. Compact the upper 6 inches of subgrade soils beneath pavements, curbs and gutters to 95 percent compaction. Extend compaction 5 feet beyond pavement edges unless specified otherwise by the Geotechnical Engineer.
 - 4. Compact the upper 6 inches of subgrade soils under walks, structures and areas to receive structural fill to 90 percent compaction.

3.11 SOIL STERILIZATION

- A. Apply soil sterilant to areas indicated, such as beneath asphalt concrete pavement, brick pavement, concrete pavement and at grade concrete slabs, including sidewalks, curbs and gutters. Also where indicated apply soil sterilant below expansion and control joints and at areas where pipes, ducts or other features penetrate slabs.
- B. Apply soil sterilant uniformly and at the rates recommended by the manufacturer.
- C. Apply soil sterilant to prepared subgrade, or after installation of aggregate base as recommended by the manufacturer.

3.12 DISPOSAL

- A. Lawfully dispose of all unsuitable and excess or surplus material off-site at no cost to the City's Representative.

END OF SECTION

SECTION 31 21 00

UTILITY TRENCHING AND BACKFILL

PART 1 - GENERAL

1.1 SECTION INCLUDES

- A. Excavation, bedding, and backfill for underground storm drain, sanitary sewer, and water piping, underground HVAC piping, electrical conduit, telephone conduit, gas piping, cable TV conduit, etc., and associated structures.
- B. Provide labor, material, equipment, and services necessary to complete the backfilling and compacting as necessary for this project. Section includes, but is not limited to:
 - 1. Select Backfill Material
 - 2. Aggregate Base
 - 3. Detectable Tape
 - 4. Trench Excavation
 - 5. Pipe Bedding
 - 6. Trench Backfill
 - 7. Trench Surfacing
- C. This section excludes drainage fill material and placement around subdrains. See Section 33 46 00 – Bioretention Subdrainage.

1.2 RELATED SECTIONS

- A. Section 22 11 16 – Domestic Water Piping
- B. Section 31 10 00 – Site Clearing
- C. Section 31 20 00 – Earthwork Moving
- D. Section 33 40 00 – Storm Drainage Utilities
- E. Section 33 46 00 – Bioretention Subdrainage

1.3 RELATED DOCUMENTS

- A. A. Geotechnical Report: Geotechnical Evaluation, Jollyman Park All-Inclusive Playground, Ninyo & Moore Geotechnical & Environmental Sciences Consultants, February 18th 2022.
- B. ASTM
 - 1. D1557, Standard Test Method for Laboratory Compaction Characteristics of Soil Using Modified Effort.
 - 2. D2321, Standard Practice for Underground Installation of Thermoplastic Pipe for Sewer and Other Gravity-Flow Applications.
- C. California Administrative Code, Title 24, Part 2 - Basic Building Regulations, Chapter 24, Excavations, Foundations, and Retaining Walls.
- D. Caltrans Standard Specifications, 2015

1. Section 19, Earthwork
2. Section 26, Aggregate Bases
3. Section 68, Subsurface Drains
4. Section 96, Geosynthetics

E. CAL/OSHA, Title 8

1.4 DEFINITIONS

A. AC: Asphalt Concrete

B. ASTM: American Society for Testing and Materials

C. Base: The layer placed between the subgrade and surface pavement in a paving system.

D. Bedding: Material from bottom of trench to bottom of pipe

E. CDF: Controlled Density Fill

F. DIP: Ductile Iron Pipe

G. Engineered Fill:

1. Soil or soil-rock material approved by the Owner and transported to the site by the Contractor in order to raise grades or to backfill excavations.
2. Contractor shall provide sufficient tests, and a written statement that all materials brought onto the project site comply with specification requirements.

H. Excavation: Consists of the removal of material encountered to subgrade elevations

I. Initial Backfill: Material from bottom of pipe to 12 inches above top of pipe

J. PCC: Portland Cement Concrete

K. RCP: Reinforced Concrete Pipe

L. Relative Compaction: In-place dry density of soil expressed as percentage of maximum dry density of same materials, as determined by laboratory test procedure ASTM D1557.

M. Springline of Pipe: Imaginary line on surface of pipe at a vertical distance of $\frac{1}{2}$ the outside diameter measured from the top or bottom of the pipe.

N. Subgrade: The uppermost surface of an excavation or the top surface of a fill or backfill immediately below base.

O. Subsequent Backfill: Material from 12 inches above top of pipe to subgrade of surface material or subgrade of surface facility or to finish grade.

P. Trench Excavation: Removal of material encountered above subgrade elevations and within horizontal trench dimensions.

1. Authorized Trench Over-Excavation: Excavation below trench subgrade elevations or beyond indicated horizontal trench dimensions as shown on plans or authorized by the Geotechnical Engineer.
2. Unauthorized Trench Over-Excavation: Excavation below trench subgrade elevations or beyond indicated horizontal trench dimensions without authorization

by the Geotechnical Engineer. Unauthorized excavation shall be without additional compensation.

- Q. Utility Structures:
1. Storm drainage manholes, catch basins, drop inlets, curb inlets, vaults, etc.
 2. Sanitary sewer manholes, vaults, etc.
 3. Water vaults, etc.

1.5 SUBMITTALS

- A. Follow submittal procedures outlined in the City of Cupertino Project Manual.
- B. Test Reports: Submit the following report for import material directly to the Owner from the Contractor's testing services:
1. Compaction test reports for aggregate base.
- C. Samples:
1. If required by the Geotechnical Engineer, provide 20-pound samples of all imported trench bedding and backfill material sealed in airtight containers, tagged with source locations and suppliers of each proposed material. Do not import materials to Project without written approval of the Geotechnical Engineer and the Owner.
 2. Provide materials from same source throughout work. Change of source requires approval of the Geotechnical Engineer and the Owner.

1.6 QUALITY ASSURANCE

- A. Conform all work and materials to the recommendations or requirements of the Geotechnical Report and meet the approval of the Geotechnical Engineer.
- B. Conform all work to the appropriate portion(s) of the Caltrans Standard Specifications, Section 19, Earthwork.
- C. Percentage of compaction specified shall be the minimum acceptable. The percentage represents the ratio of the dry density of the compacted material to the maximum dry density of the material as determined by the procedure set forth in ASTM D 1557.
- D. The Geotechnical Engineer will perform observations and tests required to enable him to form an opinion of the acceptability of the trench backfill. Correct the trench backfill that, in the opinion of the Geotechnical Engineer, does not meet the requirements of these Technical Specifications and the Geotechnical Report.

1.7 PROJECT CONDITIONS

- A. Promptly notify the Owner of surface or subsurface conditions differing from those disclosed in the Geotechnical Report. First notify the Owner verbally to permit verification and extent of condition and then in writing. No claim for conditions differing from those anticipated in the Contract Documents and disclosed in the Geotechnical Report will be allowed unless Contractor has notified the Owner in writing of differing conditions prior to contractor starting work on affected items.
- B. Barricade open excavations and post with warning lights.
1. Operate warning lights and barricades as required.

2. Protect structures, utilities, sidewalks, pavements, and other facilities immediately adjacent to excavations, from damages caused by settlement, lateral movement, undermining, washout, and other hazards.
 3. Protect open, trenches, and utility structure excavations with fences, covers and railings to maintain safe pedestrian and vehicular traffic passage.
- C. Stockpile on-site and imported backfill material temporarily in an orderly and safe manner.
- D. Provide dust and noise control in conformance with the City of Cupertino Project Manual.
- E. Environmental Requirements:
1. Protect existing storm drainage system from silt and debris resulting from construction activities. If contamination occurs, remove contamination at no cost to the District.
 2. Protect existing streams, ditches and storm drain inlets during work on this project.
- F. Protection of Subgrade: Do not allow equipment to pump or rut subgrade, stripped areas, footing excavations, or other areas prepared for project.
- G. Transport all excess soils materials by legally approved methods to disposal areas.
1. Coordinate with the Engineer.
 2. Any additional fill requirements shall be the responsibility of the Contractor.

1.8 EXISTING UTILITIES

- A. Locate existing underground utilities in the areas of work. For utilities that are to remain in place, provide adequate means of protection during excavation operations.
1. Locating of existing underground utilities shall include but not be limited to pot-holing prior to the start of construction.
- B. Should uncharted or incorrectly charted piping or other utilities be encountered during excavation, consult Owner and/or utility agency immediately for directions.
1. Cooperate with the Owner and public and private utility companies in keeping their respective services and facilities in operation.
 2. Repair damaged utilities to the satisfaction of the agency with jurisdiction.
- C. Do not interrupt existing utilities serving facilities occupied and used by the Owner or others, except when permitted in writing by the Owner and then only after acceptable temporary utility services have been provided.

PART 2 - PRODUCTS

2.1 GENERAL

- A. Import materials will be subject to approval of the Geotechnical Engineer.
- B. For approval of imported fill material, notify the Owner at least 7 days in advance of intention to import material.

2.2 PIPE BEDDING AND INITIAL BACKFILL

- A. ASTM D2321, Class IA, IB or II.
1. Clean and free of clay, silt or organic matter.

- B. Permeable Material: In accordance with Section 68-2.02F of Caltrans Standard Specifications, Class 1, Type A or Class 2.
- C. Class 2 Aggregate Base: In accordance with Section 26 of Caltrans Standard Specifications, ¾ inch maximum.
- D. Sand: In accordance with Section 19-3.02F of Caltrans Standard Specifications.

2.3 SELECT BACKFILL

- A. Select backfill material shall be gravel, free of clay or organic matter and shall conform to the following gradation:

Sieve Size	Percentage Passing
1 inch	100
¾ inch	90 – 100
No. 4	35 – 60
No. 200	2 - 9

- B. For gas pipe and fuel piping select backfill shall be clean, graded building sand conforming to the following gradation:

Sieve Size	Percentage Passing
No. 4	100
No. 200	0 -5

2.4 WARNING TAPE

- A. Polyethylene plastic and metallic core or metallic-faced, acid- and alkali-resistant, polyethylene plastic warning tape manufactured specifically for warning and identification of buried utility lines. Provide tape on rolls, 3 inch minimum width, color coded as specified below for the intended utility with warning and identification imprinted in bold black letters continuously over the entire tape length. Warning and identification to read, "CAUTION, BURIED (intended service) LINE BELOW" or similar wording. Color and printing shall be permanent, unaffected by moisture or soil.
 1. Warning Tape Color Codes
 - a. Red: Electric
 - b. Yellow: Gas, Oil; Dangerous Materials
 - c. Orange: Telephone and Other Communications
 - d. Blue: Water Systems
 - e. Green: Sewer Systems
 - f. White: Steam Systems
 - g. Gray: Compressed Air
 2. Warning Tape for Metallic Piping: Acid and alkali-resistant polyethylene plastic tape conforming to the width, color, and printing requirements specified above. Minimum thickness of tape shall be 0.003 inch. Tape shall have a minimum strength of 1500 psi lengthwise, and 1250 psi crosswise, with a maximum 350 percent elongation.
 3. Detectable Warning Tape for Non-Metallic Piping: Polyethylene plastic tape conforming to the width, color, and printing requirements specified above. Minimum thickness of the tape shall be 0.004 inch. Tape shall have a minimum strength of 1500 psi lengthwise and 1250 psi crosswise. Tape shall be manufactured with integral wires, foil backing, or other means of enabling detection by a metal detector when tape is buried up to 3 feet deep. Encase metallic element

of the tape in a protective jacket or provide with other means of corrosion protection.

2.5 DETECTION WIRE FOR NON-METALLIC PIPING

- A. Detection wire shall be insulated single strand, solid copper with a minimum of 12 AWG.

2.6 SUBSEQUENT BACKFILL

- A. Conform to on-site or imported structural backfill in Section 31 20 00, Earth Moving.

2.7 CONTROLLED DENSITY FILL (CDF) (in trenches)

- A. Provide non-structural CDF, from bottom of trench to finish subgrade of subbase or base material, that can be excavated by hand and produce unconfined compressive 28-day strengths from 50-psi to a maximum of 150-psi. Provide aggregate no larger than 3/8 inch top size. The 3/8 inch aggregate shall not comprise more than 30% of the total aggregate content.
- B. Cement: Conform to the standards as set forth in ASTM C150, Type II Cement.
- C. Fly Ash: Conform to the standards as set forth in ASTM C618, for Class F pozzolan. Do not inhibit the entrainment of air with the fly ash.
- D. Air Entraining Agent: Conform to the standards as set forth in ASTM C260.
- E. Aggregates need not meet the standards as set forth in ASTM C33. Any aggregate, producing performances characteristics described herein will be accepted for consideration. The amount of material passing a #200 sieve shall not exceed 12% and no plastic fines shall be present.
- F. Provide CDF that is a mixture of cement, Class F pozzolan, aggregate, air entraining agent and water. CDF shall be batched by a ready mixed concrete plant and delivered to the job site by means of transit mixing trucks.
- G. The Contractor shall determine the actual mix proportions of the controlled density fill to meet job site conditions, minimum and maximum strengths, and unit weight. Entrained air content shall be a minimum of 4.0%. The actual entrained air content shall be established for each job with the materials and aggregates to be used to meet the placing and unit weight requirements. Entrained air content may be as high as 20% for fluidity requirements.
- H. Mix design shall meet the Geotechnical Engineer's approval.

2.8 CONCRETE STRUCTURE BEDDING AND BACKFILL

- A. Precast Structures: Same materials to the same heights as specified for pipe bedding and backfill, or other material approved by the Geotechnical Engineer.
- B. Poured-in-Place Structures:
 - 1. Bedding: Bedding shall meet the approval of the Geotechnical Engineer. In general, bedding is not required, pour bases against undisturbed native earth in cut areas and against engineered fill compacted to 90% relative compaction in embankment areas.

2. Side Backfill: On-site or imported structural fill meeting the requirements given in Section 31 20 00, Earth Moving.

2.9 Geosynthetics

- A. Filter Fabric:
 1. Filter Fabric: Section 96-1.02 of Caltrans Standard Specifications.
 2. Mirafi 140N, Mirafi Inc., or approved equal.

PART 3 - EXECUTION

3.1 General

- A. Comply with the recommendations of the Geotechnical Engineer.
- B. Protect existing trees to remain. No grading is permitted under the drip line of protected trees.
- C. Excavations for appurtenant structures, such as, but not limited to, manholes, transition structures, junction structure, vaults, valve boxes, catch basins, thrust blocks, and boring pits, shall be deemed to be in the category of trench excavation.
- D. Unless otherwise indicated in the Plans, all excavation for pipelines shall be open cut.
- E. Prior to commencement of work, become thoroughly familiar with site conditions.
- F. In the event discrepancies are found, immediately notify the Owner in writing, indicating the nature and extent of differing conditions.
- G. Backfill excavations as promptly as work permits.
- H. Do not place engineered fill or backfill until rubbish and deleterious materials have been removed and areas have been approved by the Owner.
- I. Place acceptable soil material in layers to required subgrade elevations, for each area classification listed below.
- J. In excavations, use satisfactory excavated or borrow material.
- K. Under grassed areas, use satisfactory excavated or borrow material.

3.2 SITE PREPARATION

- A. Protect structures, utilities, sidewalks, pavements, and other facilities, which are to remain, from damage caused by settlement, lateral movement, undermining, washout, and other hazards created by earthwork operations.
- B. Protect existing storm drainage system from silt and debris resulting from construction activities. If contamination occurs, remove contamination at no cost to the Owner.

3.3 EXISTING UTILITIES

- A. Identity the location of existing utilities.

1. Prior to trenching, the Contractor shall excavate at locations specifically indicated on the Plans, if any, and where new lines cross other utilities of uncertain depth and determine the elevation of the utility in question to ensure that the new line will clear the potential obstruction.
 2. The Contractor shall contact Underground Service Alert (USA) at 1-800-227-2600 for assistance in locating existing utilities.
 3. If, after the excavation, a crossing utility does present an obstruction, then the line and grade of the new line will be adjusted as directed by the Owner to clear the utility.
- B. Protect all existing utilities to remain in operation.
- C. Movement of construction machinery and equipment over existing pipes and utilities during construction shall be at Contractor's risk.
- D. Excavation made with power-driven equipment is not permitted within 2 feet of any known utility or subsurface structure.
1. Use hand or light equipment for excavating immediately adjacent to known utilities or for excavations exposing a utility or buried structure.
 2. Start hand or light equipment excavation on each side of the indicated obstruction and continue until the obstruction is uncovered or until clearance for the new grade is assured.
 3. Support uncovered lines or other existing work affected by excavation until approval for backfill is obtained.
 4. Report damage of utility line or subsurface structures immediately to the Owner.
- E. Backfill trenches resulting from utility removal in lifts of 8 inches maximum.

3.4 TRENCH EXCAVATION

A. General

1. Excavation shall include removal of all water and materials that interfere with construction. The Contractor shall remove any water which may be encountered in the trench by pumping or other methods during the pipe laying, bedding and backfill operations. Material shall be sufficiently dry to permit approved jointing.
2. Excavation shall include the construction and maintenance of bridges required for vehicular and pedestrian traffic, support for adjoining utilities.
3. The Contractor shall be responsible to safely direct vehicular and pedestrian traffic through or around his/her work area at all times.
4. The Contractor shall relocate, reconstruct, replace or repair, at his/her own expense, all improvements which are in the line of construction or which may be damaged, removed, disrupted or otherwise disturbed by the Contractor.

B. Existing Paving and Concrete:

1. Existing pavement over trench shall be sawcut, removed, and hauled away from the job. Existing pavement shall be neatly sawcut along the limits of excavations.
2. Existing concrete over the trench shall be sawcut to a full depth in straight lines, at a minimum distance of 12 inches beyond the edge of the trench, either parallel to the curb or at right angles to the alignment of the sidewalk.
3. Boards or other suitable material shall be placed under equipment outrigging to prevent damage to paved surfaces.

C. Trench Width:

1. The maximum allowable trench widths at the top of the all pipe materials outside diameter of barrel pipe plus 18 inches. shall be as follows:

- a. The maximum trench width shall be inclusive of all shoring.
 - b. If the maximum trench width is exceeded, the State's representative may direct the Contractor to encase or cradle the pipe in concrete at no additional charge.
 2. For pipes 3 inch diameter and larger, the free working space on each side of the pipe barrel shall not be less than 6 inches.
 - D. Excavation Width at Springline of Pipe:
 1. Up to a nominal pipe diameter of 24 inches: Minimum of twice the outside pipe diameter, or as otherwise allowed or required by the Geotechnical Engineer.
 2. Nominal pipe diameter of 30 inches through 36 inches: Minimum of the outside pipe diameter plus 2 feet, or as otherwise allowed or required by the Geotechnical Engineer.
 3. Nominal pipe diameter of 42 inches through 60 inches: Minimum of the outside pipe diameter plus 3 feet, or as otherwise allowed or required by the Geotechnical Engineer.
 - E. Open Trench:
 1. The maximum length of open trench shall be 300 feet or the distance necessary to accommodate the amount of pipe installed in a single day, whichever is greater. No trench shall be left open at the end of the day.
 2. Provisions for trench crossings and free access shall be made at all street crossings, driveways, water gate valves, and fire hydrants.
 3. Excavate by hand or machine. For gravity systems begin excavation at the outlet end and proceed upstream. Excavate sides of the trench parallel and equal distant from the centerline of the pipe. Hand trim excavation. Remove loose matter.
 4. Excavation Depth for Bedding: Minimum of 6 inches below bottom of pipe or as otherwise allowed or required by the Geotechnical Engineer, except that bedding is not required for nominal pipe diameters of 2 inches or less.
 5. Over-Excavations: Backfill trenches that have been excavated below bedding design subgrade, with approved bedding material.
 6. Where forming is required, excavate only as much material as necessary to permit placing and removal of forms.
 7. Grade bottom of trench to provide uniform thickness of bedding material and to provide uniform bearing and support for pipe along entire length. Remove stones to avoid point bearing.
 - F. Excavated Material:
 1. All excavated material not required for backfill shall be immediately removed and properly disposed of in a legal manner by the Contractor.
 2. Material excavated in streets and roadways shall be laid alongside the trench no closer than 2 feet from the trench edge and kept trimmed to minimize inconvenience to public traffic.
 3. Provisions shall be made whereby all storm and wastewater can flow uninterrupted in gutters or drainage channels.
- 3.5 CONTROL OF WATER AND DEWATERING
- A. Be solely responsible for dewatering trenches and excavations and subsequent control of ground and surface water. Provide and maintain such pumps or other equipment as may be necessary to control ground water and seepage to the satisfaction of the Geotechnical Engineer and the Owner until backfilling is completed.

- B. Dewater during backfilling operation so that groundwater is maintained a least one foot below level of compaction effort.
- C. Obtain the Geotechnical Engineer's approval for proposed control of water and dewatering methods.
- D. Reroute surface water runoff away from open trenches and excavations. Do not allow water to accumulate in trenches and excavations.
- E. Maintain dewatering system in place until dewatering is no longer required.

3.6 BRACING AND SHORING

- A. Conform to California and Federal OSHA requirements.
- B. Place and maintain such bracing and shoring as may be required to support the sides of the excavations for the proper protection of workmen; to facilitate the work; to prevent damage to the pipes and appurtenances being constructed; and to prevent damage to adjacent structures or facilities. Remove all bracing and shoring upon completion of the work.
- C. Be solely responsible for all bracing and shoring and, if requested by the Owner, submit details and calculations to the Owner. The Owner may forward the submittal to the Geotechnical Engineer, the Consulting Engineer and/or the California Division of Industrial Safety for their review. The Contractor's submittal shall include the basic design, assumed soils conditions and estimation of forces to be resisted, together with plans and specifications of the materials and methods to be used, and shall be prepared by a civil engineer or structural engineer registered in California. No excavations in trench section or around structures shall precede a response to the submittal by the Owner.
- D. Be solely responsible for installing and extracting the sheathing in a manner which will not disturb the line, grade, or backfill compaction or operation of the utility being installed or adjacent utilities and facilities.

3.7 PIPE BEDDING

- A. Obtain approval of bedding material from the Geotechnical Engineer.
- B. Accurately shape bedding material to the line and grade called for on the Plans. Carefully place and compact bedding material to the elevation of the bottom of the pipe in layers not exceeding 8 inches in loose thickness. Compact bedding material at optimum water content to 90% relative compaction unless specified otherwise on the Plans or by the Geotechnical Engineer. Compact by pneumatic tampers or other mechanical means approved by the Geotechnical Engineer. Jetting or ponding of bedding material will not be permitted.
- C. Stabilization of Trench Bottom: When the trench bottom is unstable due to wet or spongy foundation, trench bottom shall be stabilized with gravel or crushed rock. The State's inspector will determine the suitability of the trench bottom and the amount of gravel or crushed rock needed to stabilize a soft foundation. Soft material shall be removed and replaced with gravel or crushed rock as necessary.
- D. Placement of Bedding Material: The trench bottom shall be cleaned to remove all loose native material prior to placing select backfill material. Sufficient select backfill material shall be placed in trench and tamped to bring trench bottom up to grade of the bottom of

pipe. The relative compaction of tamped material shall be not less than 90 percent. It is the intention of these requirements to provide uniform bearing under the full length of pipe to a minimum width of 60 percent of the external diameter.

3.8 BACKFILLING

A. Initial Backfill:

1. Obtain approval of backfill material from Geotechnical Engineer.
2. Bring initial backfill up simultaneously on both sides of the pipe, so as to prevent any displacement of the pipe from its true alignment. Carefully place and compact initial backfill material to an elevation of 12 inches above the top of the pipe in layers not exceeding 8 inches in loose thickness. Compact bedding material at optimum water content to 90% relative compaction unless specified otherwise on the Plans or by the Geotechnical Engineer. Compact by pneumatic tampers or other mechanical means approved by the Geotechnical Engineer. Jetting or ponding of initial backfill material will not be permitted.

B. Pipe Detection: In trenches containing pressurized plastic pipes, tracer wire shall be placed directly above the pipe and shall be connected to all valves, existing exposed tracer wires, and other appurtenances as appropriate.

C. Installation of Tracer Wire:

1. Install a continuous length of tracer wire for the full length of each run of nonmetallic pipe.
2. Attach wire to top of pipe in such manner that it will not be displaced during construction operations.
3. Form a mechanically and electrically continuous line throughout the pipeline, extending to the nearest valve or other pipeline appurtenance. Extend the wire up the outside of the valve box/riser and cut a hole that is 8 inches from the top, extend a 12 inch wire lead to the inside of the box. At other pipeline appurtenances, terminate the 12 inch wire lead inside the enclosure.
4. Splice wire with a splicing device consisting of an electro-tin plated seamless copper sleeve conductor. Install as recommended by the manufacturer. Wrap splices and damaged insulation with electrician's tape.

D. Installation of Warning Tape

1. Install tape approximately 1 foot above and along the centerline of the pipe.
2. Where tape is not continuous lap tape ends a minimum of 2 feet.

E. Subsequent Backfill:

1. Above the level of initial backfill, the trench shall be backfilled with non-expansive native material from trench excavation or with imported select backfill material (Contractor's option). Subsequent backfill shall be free of vegetable matter, stones or lumps exceeding 3 inches in greatest dimension, and other unsatisfactory material.
2. Bring subsequent backfill to subgrade or finish grade as indicated. Carefully place and compact subsequent backfill material to the proper elevation in layers not exceeding 8 inches in loose thickness. Compact bedding material at optimum water content to 90% relative compaction, except that the upper 36 inches in areas subject to vehicular traffic shall be compacted to at least 95% relative compaction, unless specified otherwise on the Plans or by the Geotechnical Engineer. Compact by pneumatic tampers or other mechanical means approved by the Geotechnical Engineer. Jetting or ponding of subsequent backfill material will not be permitted.

- F. Do not use compaction equipment or methods that produce horizontal or vertical earth pressures that may cause excessive pipe displacement or damage the pipe. Jetting of trench backfill is not permitted.
- G. Utility backfill shall be inspected and tested by the Geotechnical Engineer during placement. Cooperate with the Geotechnical Engineer and provide working space for such tests in operations. Backfill not compacted in accordance with these specifications shall be re-compacted or removed as necessary and replaced to meet the specified requirements, to the satisfaction of the Geotechnical Engineer and the Owner prior to proceeding with the Project.
- H. Compaction testing shall be in accordance with California Test Method ASTM D1556 or D1557.

3.9 CLEANUP

- A. Upon completion of utility earthwork all lines, manholes catch basins, inlets, water meter boxes and other structures shall be thoroughly cleaned of dirt, rubbish, debris and obstructions of any kind to the satisfaction of the Owner.

END OF SECTION

SECTION 312200

GRADING

PART 1 - GENERAL

1.1 SUMMARY

- A. Section Includes: All labor, materials, equipment, tools, accessories, transportation, and services as required for Grading, including:
 - 1. Excavation and/or mounding of project site.
 - 2. Furnishing and placing approved borrow or import as necessary to meet grades shown on the plan.
 - 3. Subgrade preparation and compaction.

- B. Related Requirements
 - 1. Refer to City of Cupertino Project Manual
 - 2. Section 024100, Demolition
 - 3. Section 311000, Site Clearing
 - 4. Section 328400, Irrigation
 - 5. Section 329300, Planting
 - 6. Section 334000, Storm Drainage Utilities

1.2 PRICE AND PAYMENT PROCEDURES

- A. Refer to City of Cupertino Project Manual.

1.3 REFERENCES

- A. ASTM
 - 1. C33: Concrete Aggregates.
 - 2. D1557: Test Methods for Moisture-Density Relations of Soils and Soil-Aggregate Mixtures Using ten pound (10 lb. or 0.54 kg) Rammer and eighteen inch (18" or 457 mm) Drop.
 - 3. D2922: Density of Soil and Soil Aggregate in Place by Nuclear Methods (Shallow Depths).

- B. California Administrative Code, Title 24, Part 2 – Basic Building Regulations, Chapter 24 – Excavations, Foundations, and Retaining Walls.

- C. Current CalTrans Standard Specifications
 - 1. Standard Test Methods: No. 231.

- D. CCR, Title 8, Industrial Relations.

- E. Geotechnical Report: Geotechnical Evaluation, Jollyman Park All-Inclusive Playground, Ninyo & Moore Geotechnical & Environmental Sciences Consultants, February 18th 2022.

ADMINISTRATIVE REQUIREMENTS

- F. Sequencing: Contractor shall perform the following tasks in this order:
1. Rough grading shall occur prior to layout of surface features.
 2. Layout of underground utilities shall occur prior to trenching.
 3. Fine grading shall occur prior to planting.

1.4 SUBMITTALS

- A. All tests indicating conformance to project requirements shall be paid for by the Contractor. Costs of retesting and reinspection required as the result of inadequate, insufficient, or incomplete work by the Contractor shall be deducted from the contract amount.
- B. Site Test Reports: Provide a complete soil analysis of any proposed imported soil from Soil and Plant Laboratory, Inc., 352 Mathew Street, Santa Clara, CA, 95050, (408) 727-0330, or approved equal.
- C. Samples: Samples of all proposed imported materials, minimum eighty (80) pounds, tagged with source location and supplier shall be submitted to the Geotechnical Consultant or his representative at least fifteen (15) days prior to import. Materials shall not be imported to jobsite without written approval by the City's Representative.
- D. Trench Excavation and Shoring: The Contractor shall provide the City's Representative with a letter identifying the company's "Competent Person" overseeing excavation activities, and a copy of the company's current OSHA permit. The Contractor shall also submit for approval a trench excavation safety plan conforming to Sections 5-1.02A and 7-1.01E of the State Standard Specifications.
- E. Compaction Test Method: Where referred to in these specifications, "compaction" or "relative compaction" shall mean the in-place dry density of soil expressed as a percentage of the maximum dry density of the same material as determined by ASTM D-1557.
- F. The Contractor shall provide compaction testing as required to confirm compliance with these plans and specifications. All costs of such testing will be borne by the City, except as specified in Section 014000, Quality Requirements.
- G. City Representative shall be present during all site clearing and grading operations to test and to observe earthwork construction. City Representative shall be notified at least two working days prior to commencement of any grading operations to allow for discussion and planning with the earthwork, underground and paving contractors.

1.5 DELIVERY, STORAGE, AND HANDLING

- A. Materials: Attention is directed to Section 6, Control of Materials, of the Caltrans Standard Specifications and these Special Provisions. All materials required to complete the work under this contract shall be furnished by the Contractor.

1.6 WARRANTY

- A. Final Guarantee: Contractor shall provide guarantee according to City of Cupertino General Conditions.

1.7 SITE CONDITIONS

- A. Reference Points: All bench marks, monuments, signs, and other reference points shall be maintained; if disturbed or destroyed, they shall be replaced by the Contractor as directed by the City's Representative.
- B. Ambient Conditions: When unfavorable weather conditions necessitate interrupting filling and grading operations, areas shall be prepared by compaction of surface and grading to avoid collection of water. Adequate temporary drainage shall be provided to prevent erosion. After interruption, compaction specified in last layer shall be verified or reestablished before resuming.
- C. Dewatering: No soil shall be compacted during periods of rain or when the ground is not drained of all free water. Soil that has been stockpiled and wetted by rain or by any other cause shall not be compacted until completely drained and until the moisture content is within the limits approved by the City.

PART 2 - PRODUCTS

2.1 FILL MATERIALS

- A. Existing material may be used for fill after removal of all debris, and after being moisture-conditioned, if it meets the criteria in paragraph B below.
- B. Soil imported to the site and used for compacted fill shall be free of perishable organic material, and shall meet the following requirements:
 - 1. Physical: Close Graded with 35% or more passing No. 4 sieve and either:
Expansion Index of 50 or less, Plasticity Index of 15 or less, or less than 10% by dry weights passing through No. 200 sieve.
 - 2. Chemical: Salinity Limit (ECe) saturation extract of 4.0 sodium (SAR) limit of less than 8.0.
 - 3. Boron: Saturation extraction concentration less than 1.0 ppm.
- C. Minor quantities of material not meeting the above gradation may be mixed and blended with other on-site material if the resulting mixture conforms to the specifications. If the quantity of material not in conformance with the specifications becomes excessive in the opinion of the Geotechnical Engineer, it shall be removed from the site.
- D. Topsoil: See Section 32 93 00, Planting, for topsoil requirements.

PART 3 - EXECUTION

3.1 EXAMINATION

- A. Verification of Conditions: Prior to commencement of site grading work the Contractor shall notify the City's Representative that the site has been cleared. The City's Representative shall have sufficient time to review the site. Site grading shall not commence until the City's Representative has completed review of the site and the City has given approval to proceed.

3.2 PREPARATION

- A. Protection of In-Place Conditions
 - 1. Surrounding areas, surfaces and appurtenances already in place shall be protected during grading.
- B. Existing irrigation lines to be abandoned shall be capped as directed by City's Representative. All hose bibs, valves and sprinkler heads removed from the project area prior to commencement of construction shall be salvaged in accordance with these Specifications or as directed by the City's Representative.
- C. In the event irrigation lines are discovered passing through the project area to other areas, lines shall be rerouted and maintained in operation during construction as directed by the City's Representative.

3.3 GRADING

- A. The Contractor shall be responsible for meeting the finish grades as shown on the plans. Should importation of material be required, the source of import shall be approved by the City's Representative prior to delivery to the site. Should a net cut result, the Contractor shall dispose of the excess material off-site.
- B. All areas covered by the project, including excavated and filled areas and adjacent transition areas, shall be uniformly graded so those finished surfaces are at the elevations established by the Plans. See Section 329300, Planting, for more specific planting area requirements.
- C. Finished surfaces and surfaces to receive paving and aggregate base shall be smooth, compacted, and free from irregular surface drainage and shall not vary more than 0.10 feet from the established grade.
- D. Ditches, gutters, and swales shall be finished to provide proper surface drainage, per approved plans.
- E. Any excavated trenches deeper than two (2) feet deep shall be backfilled at the end of each day. All other trenches less than two (2) feet deep shall be adequately barricaded at the end of each day to the satisfaction of the City's Representative.

3.4 SUBGRADE PREPARATION

- A. Subgrade preparation is required under all paved areas, curbs, gutters, walks or structures.
- B. Surfaces outside designated Tree Protection Zones (TPZ) shall be scarified to a depth of at least six inches (6") below the final subgrade elevation. The soil material shall be brought to a finely divided condition by harrowing, drying rolling and breaking clods. All boulders or solid rock encountered shall be removed. The soil material shall be uniform for the full depth and width of the subgrade.
- C. For surfaces within TPZ, allowance depth and methods of scarification shall be coordinated with the Project Arborist and the Geotechnical Engineer.

3.5 FILLING

- A. The placement of fills shall be done under the supervision of the City's Representative or designated Geotechnical Consultant.
- B. Jetting of material shall not be permitted.
- C. All areas to receive fills shall be uniformly moisture conditioned as required to obtain the required compaction. Where slopes exceed four (4) horizontal to one (1) vertical, initial fill shall be keyed into slope. Areas to receive fills within TPZ shall be coordinated with the Project Arborist and the Geotechnical Engineer.
- D. Fill material outside of planting areas shall be spread in uniform lifts of not more than eight inches (8") in uncompacted thickness. Prior to commencing compaction, fills shall be brought to a uniform water content that will permit proper compaction by either aerating the material if it is too wet, or spraying the material with water if it is too dry. Each lift shall be thoroughly mixed before compactions to assure uniform distribution of water content. All fills shall be brought to suitable elevations above grade to provide for anticipated settlement, slope trimming or shrinkage thereof.
- E. Fill shall not be dropped on any structure. Backfill shall not be placed around, against, or upon any concrete or masonry structure until structure has attained sufficient strength to withstand the loads imposed and the horizontal structural system has been installed.

3.6 COMPACTION

- A. Fill material shall be compacted with equipment of such weight and design as necessary to obtain the specified compaction. Fill shall be compacted to eighty-five percent (85%) relative compaction in areas to be planted and at least ninety percent (90%) relative compaction in areas to be paved unless otherwise directed. In pavement areas, the upper nine inches (9") of subgrade shall have a minimum relative compaction of ninety-five percent (95%). The resulting subgrade should be smooth and essentially unyielding. Between successive lifts, the fill surface shall be scarified or otherwise processed to obtain satisfactory bonding between the fill lifts.
- B. Recompanction: Where, in the judgment of the Geotechnical Engineer, the moisture content is not suitable or insufficient compaction has been obtained, the fill shall be reconditioned and/or recompancted to the specified density prior to placing any additional

fill material. The Contractor shall be responsible for placing and compacting approved fill material in accordance with these specifications. If the Contractor fails to meet the compaction requirements, he shall reduce his rate of haul, furnish additional spreading, moisture conditioning and/or compacting equipment or make any other adjustments necessary to produce a satisfactory compacted fill.

3.7 SITE QUALITY CONTROL

- A. Excess Material: Excess material shall be removed by the Contractor to an off-site in a legal manner. The Contractor shall submit to the City's Representative the locations of the off-site for approval.
- B. All excavation, filling, and compaction shall be performed under the direct observation of the City's Representative or designated Geotechnical Consultant. The Contractor shall cooperate with the City's Representative or designated Geotechnical Consultant in all aspects of the work. Any materials placed or improvements constructed in the absence of the City's Representative or designated Geotechnical Consultant's approval to proceed shall be presumed to be defective. At the discretion of the City's Representative, the areas in question shall be removed and replaced at no cost to the City. The City's Representative or designated Geotechnical Consultant shall be notified at least forty-eight (48) hours prior to require observation or testing.
- C. Embankments shall be maintained to the grades shown on the plans until completion and acceptance of the Contract. Suitable allowance for shrinkage shall be provided for by the Contractor.
- D. The Contractor shall be responsible for the stability of all constructed embankments, and shall replace any portion which, in the City's Representative's opinion, has been displaced due to the Contractor's negligence.
- E. The finish soil grade tolerance at the completion of grading is as follows: building and paved areas: +0 to -0.10 feet. Other areas: ± 0.10 feet.
- F. Site Tests and Inspections
 - 1. When the Contractor indicates that site grading is complete and conforming to the plans. City Surveyors may verify the grades. Any discrepancies with the grading plan must be corrected by the Contractor.
 - 2. City's Representative shall approve finish grades prior to removal of earth moving equipment from project site and prior to turfing and planting operations.
 - 3. Resistance Value (R Value): The R Value of soil materials shall be as determined by California Test Method No. 301.

3.8 PROTECTION

- A. The Contractor shall protect open excavations, trenches, and the like with fences, covers and railings as required, to maintain safe pedestrian and vehicular traffic passage.
- B. The Contractor shall prevent erosion of freshly graded areas during construction and until such time as a permanent drainage and erosion control measures have been installed.

- C. Earthwork operations shall be conducted so as to prevent windblown dust and dirt from interfering with the surrounding normal operations. Contractor shall assume liability for all claims related to windblown dust and dirt. Water shall be applied in conformance with applicable provisions of Section 17 of the State Standard Specifications and with Section 1590 (e) of CAL/OSHA, Title 8.

3.9 CLEANING:

- A. Excess Material: Removal of excess excavated material: Excess material shall be removed by the Contractor to an off-site location in a legal manner. The Contractor shall submit to the City's Representative the locations for approval. The Contractor shall be responsible to pay for any analytical testing of the excess material that may be required by the disposal facility.

3.10 ATTACHMENTS

- A. Geotechnical report: Geotechnical Evaluation, Jollyman Park All-Inclusive Playground, Ninyo & Moore Geotechnical & Environmental Sciences Consultants, February 18th 2022.

END OF SECTION

SECTION 32 09 00
TEMPORARY TREE AND PLANT PROTECTION

PART 1 - GENERAL

1.1 RELATED DOCUMENTS

- A. Refer to City of Cupertino Project Manual

1.2 PRICE AND PAYMENT PROCEDURES

- A. Refer to City of Cupertino Project Manual

1.3 SUMMARY

- A. Section includes general protection and pruning of existing trees and plants that are affected by execution of the Work, whether temporary or permanent construction.
- B. Contractor shall provide all labor and materials necessary to complete tree protection as specified.
- C. Tree protection includes watering trees, installing fences around trees, and protective measures described below.
- D. Related Sections:
 - 1. Section 31 10 00, "Site Clearing" for removing existing trees and shrubs.

1.4 DEFINITIONS

- A. Caliper: Diameter of a trunk measured by a diameter tape 6 inches above the ground for trees up to, and including, 4-inch size; and 12 inches above the ground for trees larger than 4-inch size.
- B. Tree-Protection Zone: Area surrounding individual trees or groups of trees to be protected during construction and defined by a circle concentric with each tree with a radius defined as one-foot radial distance for every one inch in tree diameter as indicated on Tree Protection Plan.
- C. Vegetation: Trees, shrubs, groundcovers, grass, and other plants.

1.5 SUBMITTALS

- A. Provide Submittals in accordance with Section 01 30 00 Administrative Requirements.
- B. Product Data: For each type of product indicated.

- C. Samples for Verification: For each type of the following:
1. Organic Arbor Mulch: One-half (1/2) pound of organic mulch; in sealed plastic bags labeled with composition of materials by percentage of weight and source of mulch.
 2. Tree -Protection-Zone Fencing: Assembled Samples of manufacturer's standard size made from full-size components.
 3. Protection-Zone Signage: Full-size Samples of each size and text, ready for installation.
- D. Qualification Data: For qualified ISA Certified arborist and tree service firm.
- E. Certification: From arborist, certifying that trees indicated to remain have been protected during construction according to recognized standards and that trees were promptly and properly treated and repaired when damaged.
- F. Maintenance Recommendations: From arborist, for care and protection of trees affected by construction during and after completing the Work, including watering recommendations.
- G. Existing Conditions: Documentation of existing trees and plantings indicated to remain, which establishes preconstruction conditions that might be misconstrued as damage caused by construction activities.
1. Use sufficiently detailed photographs or videotape.
 2. Include plans and notations to indicate specific wounds and damage conditions of each tree or other plants designated to remain.

1.6 QUALITY ASSURANCE

- A. Preinstallation Conference: Conduct conference at Project site.
1. Review methods and procedures related to temporary tree and plant protection including, but not limited to, the following:
 - a. Construction schedule. Verify availability of materials, personnel, and equipment needed to make progress and avoid delays.
 - b. Enforcing requirements for protection zones.
 - c. Arborist's responsibilities.
 - d. Field quality control.

1.7 PROJECT CONDITIONS

- A. The following practices are prohibited within protection zones:
1. Storage of construction materials, debris, or excavated material.
 2. Parking vehicles or equipment.
 3. Foot traffic.
 4. Erection of sheds or structures.
 5. Impoundment of water.
 6. Excavation or other digging without supervision of Arborist unless otherwise indicated.
 7. Attachment of signs to or wrapping materials around trees or plants unless otherwise indicated.

- B. Do not direct vehicle or equipment exhaust toward protection zones.
- C. Prohibit heat sources, flames, ignition sources, and smoking within or near protection zones and organic mulch.

PART 2 - PRODUCTS

2.1 MATERIALS

- A. Organic Arbor Mulch: Locally produced arbor mulch shall be used as a 6" deep protective cover for soil. Mulch shall be free from deleterious materials and suitable as a top dressing for trees and shrubs, consisting of one of the following:
 - 1. Type: Locally produced arbor mulch from tree and shrub trimmings.
 - 2. Size Range: 3 inches maximum, 1/2 inch minimum.
 - 3. Color: Natural.
- B. Tree-Protection-Zone Fencing: Fencing fixed in position and meeting the following requirements. Previously used materials may be used when approved by project manager.
 - 1. Chain-Link Protection-Zone Fencing: Galvanized-steel fabricated from minimum 2-inch opening, 0.148-inch- diameter wire chain-link fabric; with pipe posts, minimum 2-3/8-inch- OD line posts, and 2-7/8-inch- OD corner and pull posts; with 1-5/8-inch- OD top rails ; with 0.177-inch- diameter top tension wire and 0.177-inch diameter bottom tension wire; with tie wires, hog ring ties, and other accessories for a complete fence system.
 - a. Height: Per City of Cupertino std dtls (Dtl 6 / L5.20)
- C. Tree Trunk Protection material: Orange plastic construction fencing or straw waddles.

PART 3 - EXECUTION

3.1 EXAMINATION

- A. Erosion and Sedimentation Control: Examine the site to verify that temporary erosion- and sedimentation-control measures are in place. Verify that flows of water redirected from construction areas or generated by construction activity do not enter or cross protection zones.

3.2 PREPARATION

- A. Locate and clearly identify trees, shrubs, and other vegetation to remain. Tie a 1-inch blue-vinyl tape around each tree trunk at 54 inches above the ground.
- B. Protect tree root systems from damage caused by runoff or spillage of noxious materials while mixing, placing, or storing construction materials. Protect root systems from ponding, eroding, or excessive wetting caused by dewatering operations.
- C. Tree-Protection Zones: Mulch areas inside tree-protection zones and other areas indicated.

1. Apply 6-8-inch average thickness of organic arbor mulch. Do not place mulch within 6 inches of tree trunks.
2. $\frac{3}{4}$ " Plywood on top of mulch.

3.3 TREE- AND PLANT-PROTECTION ZONES

- A. Protection-Zone Fencing: Contractor shall indicate proposed locations of all protection zones and fencing, to protect existing trees to remain, for approval by the Owner's Representative, prior to installation. Fencing shall be per drawings, unless authorized by the Owner's Representative. Use chalk paint or other approved method. Install protection-zone fencing along edges of protection zones before materials or equipment are brought on the site and construction operations begin in a manner that will prevent people and animals from easily entering protected area except by entrance gates. Construct fencing so as not to obstruct safe passage or visibility at vehicle intersections where fencing is located adjacent to pedestrian walkways or in close proximity to street intersections, drives, or other vehicular circulation.
1. Chain-Link Fencing: Install to comply with ASTM F 567 and with manufacturer's written instructions.
 2. Posts: Set or drive posts into ground one-third the total height of the fence without concrete footings. Where a post is located on existing paving or concrete to remain, provide appropriate means of post support acceptable to Architect.
 3. Access Gates: Adjust to operate smoothly, easily, and quietly, free of binding, warp, excessive deflection, distortion, nonalignment, misplacement, disruption, or malfunction, throughout entire operational range. Confirm that latches and locks engage accurately and securely without forcing or binding.
- B. Protection-Zone Signage: Install protection-zone signage in visibly prominent locations in a manner approved by Owner's Representative. Install one sign spaced approximately every 20 feet on protection-zone fencing, but no fewer than two signs with each facing a different direction.
- C. Maintain protection zones free of weeds and trash.
- D. Repair or replace trees, shrubs, and other vegetation indicated to remain or be relocated that are damaged by construction operations, in a manner approved by Architect.
- E. Maintain tree-protection-zone fencing and signage in good condition as acceptable to Architect and remove when construction operations are complete and equipment has been removed from the site.
1. Do not remove protection-zone fencing, even temporarily, to allow deliveries or equipment access through the protection zone.
 2. Temporary access is permitted subject to preapproval in writing by arborist if a root buffer effective against soil compaction is constructed. Root buffer shall consist of a 6-8 inch layer of organic arbor mulch covered with 4'x8' plywood sheets where access is needed. Maintain root buffer so long as access is permitted.

3.4 EXCAVATION

- A. General: Excavate at edge of protection zones and for trenches indicated within protection zones according to requirements in Division 31 Section "Earth Moving."
- B. Trenching near Trees: Where utility trenches are required within tree root protection zones, hand excavate under or around tree roots or tunnel under the roots by drilling, auger boring, or pipe jacking. Do not cut main lateral tree roots or taproots; cut only smaller roots that interfere with installation of utilities. Cut roots as required for root pruning, as directed by arborist.
- C. Redirect roots in backfill areas where possible. If encountering large, main lateral roots, expose roots beyond excavation limits as required to bend and redirect them without breaking. If encountered immediately adjacent to location of new construction and redirection is not practical, cut roots approximately 3 inches back from new construction and as required for root pruning.
- D. Do not allow exposed roots to dry out before placing permanent backfill. Provide temporary earth cover or pack with peat moss and wrap with burlap. Water and maintain in a moist condition. Temporarily support and protect roots from damage until they are permanently relocated and covered with soil.

3.5 ROOT PRUNING

- A. Prior to trenching, layout main and lateral line locations within Drip Line of trees and review locations with Owner's Representative. Examine proposed trench areas for possible conflicting tree roots by hand digging (potholes) to determine tree root sizes and locations. Relocate any lines that may interfere with existing root systems to avoid or reduce damage to root systems as accepted by Arborist / Owner's Representative.
- B. All construction activity within the Tree Protection Zone, including pruning of all tree roots, to be supervised and approved by the Arborist. Hand dig where required within the tree protection zone. Expose and preserve all roots for inspection. Keep roots covered with moist burlap while waiting for inspection.
- C. Roots shall be cut cleanly, as far from the trunk of the tree as possible, and not underneath the newly constructed sidewalk. Root pruning shall be to a depth of 18".
- D. Root pruning shall be performed using a Vermeer Root Cutting Machine. Alternate equipment or techniques must be approved by the arborist. Root pruning shall be completed prior to base or subgrade preparation.
- E. Selected cuts shall be made using sharp, clean tools, ensuring rapid coverage of cuts with moist native soils.
- F. Root pruning shall be completed prior to base or subgrade preparation, or to any excavation adjacent to the tree.
- G. Excavation in an area where roots are present shall not cause the tearing or ripping of tree roots. Roots must first be cleanly severed prior to continuing with the excavation, or they must be tunneled around to prevent damage to the root.
- H. Tree roots shall not remain exposed to drying out. Root ends shall be covered with soil or burlap and kept moist until the final backfill or grade is established.

- I. Prophylactic deep root fertilization and crown cleaning to reduce excessive end weights may be considered.

3.6 WATERING

- A. Contractor shall provide water according to the schedule recommended by the arborist (see 1.4E), so that trees remain in good health throughout construction and during the maintenance period.
- B. Protect the tree trunk and root crown from water, and ensure all water is absorbed by the soil without any ponding or run-off.

3.7 FIELD QUALITY CONTROL

- A. Inspections: Engage a qualified arborist to direct plant-protection measures in the vicinity of trees, shrubs, and other vegetation indicated to remain and to prepare inspection reports.
- B. Approvals: Submit name of arborist for approval by Owner's Representative, prior to beginning any demolition or construction. Submit a copy of arborist's inspection report of recommendations for plant-protection for existing plants and trees to remain, prior to demolition operations, and prior to acceptance of the Tree-and Plant-Protection Zones by Owner's Representative.
- C. Additions to Arborist's Report: Through duration of project, the arborist shall add to the arborist's report a record of the arborist's root cutting, branch pruning, damage repair to trees and shrubs, recommendations, or other remedial actions taken by Contractor or arborist. At construction completion, as part of final walk-throughs of landscape planting installation, Contractor shall deliver arborist's final report.

3.8 REPAIR AND REPLACEMENT

- A. General: Repair or replace trees, shrubs, and other vegetation indicated to remain or be relocated that are damaged by construction operations, in a manner approved by Owner's Representative.
 1. Submit details of proposed root cutting and tree and shrub repairs.
 2. Have arborist perform the root cutting, branch pruning, and damage repair of trees and shrubs.
 3. Treat damaged trunks, limbs, and roots according to arborist's written instructions.
 4. Perform repairs within 24 hours.
 5. Replace vegetation that cannot be repaired and restored to full-growth status, as determined by Owner's Representative.
- B. Trees: Remove and replace trees indicated to remain that are damaged during construction operations that Owner's Representative determines are incapable of restoring to normal growth pattern.
 1. Provide new trees of same size and species as those being replaced for each tree that measures 4 inches or smaller in caliper size.

2. Provide two new trees of 4-inch caliper size for each tree being replaced that measures more than 4 inches in caliper size.
3. Plant and maintain new trees as specified in Division 32 Section "Planting."

3.9 DISPOSAL OF SURPLUS AND WASTE MATERIALS

- A. Disposal: Remove excess excavated material, displaced trees, trash and debris, and legally dispose of them off Owner's property.

END OF SECTION

SECTION 321100

BASE COURSES

PART 1 - GENERAL

1.1 SUMMARY

- A. Section Includes: All labor, materials, equipment, tools, accessories, transportation, and services as required for furnishing and installing aggregate base under.
 - 1. Rigid paving
 - 2. Concrete mow bands
 - 3. Concrete curb and gutter
 - 4. Concrete play area curbs and seat walls
 - 5. Miscellaneous footings and pads (as for signs, light posts, drinking fountains, bridge footings, and other items) as indicated on the plans.
- B. Related Requirements
 - 1. Section 321300, Rigid Paving
 - 2. Section 31 20 00, Earth Moving

1.2 PRICE AND PAYMENT PROCEDURES

- A. Refer to City of Cupertino Project Manual.

1.3 REFERENCES

- A. Geotechnical report: Geotechnical Evaluation, Jollyman Park All-Inclusive Playground, Ninyo & Moore Geotechnical & Environmental Sciences Consultants, February 18th 2022.
- B. Caltrans Standard Specifications, 2022
 - 1. Section 24, Stabilized Soils
 - 2. Section 25, Aggregate Subbases
 - 3. Section 26, Aggregate Bases
 - 4. Section 27, Cement Treated Bases

1.4 DELIVERY, STORAGE, AND HANDLING

- A. Materials: Attention is directed to Section 6, Control of Materials, of the Caltrans Standard Specifications and these Special Provisions. All materials required to complete the work under this contract shall be furnished by the Contractor.

1.5 WARRANTY

- A. Final Guarantee: Contractor shall provide guarantee according to City of Cupertino General Conditions.

PART 2 - PRODUCTS

2.1 BASE COURSES

A. Materials

1. Rigid Paving Base Courses: Aggregate base course for concrete paving shall be Class 2, three fourths inch (3/4") maximum as per Caltrans Standard Specification Section 26, Aggregate Bases and Geotechnical Report.
2. Flexible Paving Base Courses: Aggregate base course for asphalt paving shall be Class 2, three fourths inch (3/4") maximum, as specified in Caltrans Standard Specification Section 26, Aggregate Bases and Geotechnical Report.
3. All subgrade to receive aggregate base shall have been completely tested and approved by the City's Representative prior to the importation of aggregate base onto the site. See Caltrans Standard Specification Section 26, Aggregate Bases for subgrade preparation and Geotechnical Report.

PART 3 - EXECUTION

3.1 PREPARATION

A. Protection of In-Place Conditions

1. Surrounding areas, surfaces and appurtenances already in place shall be protected during installation of base courses.

B. Surface Preparation

1. Subgrade preparation shall be performed on all areas to receive aggregate base as first, required by the Geotechnical Report, and secondarily, following Caltrans Standard Specification Section 26, Aggregate Bases.

3.2 INSTALLATION

A. Placement: Place the aggregate base course in accordance with Caltrans Standard Specification Section 26, Aggregate Bases..

B. Compaction: Compact the aggregate base course as specified in Section 312200, Grading, of these specifications, the Geotechnical Report, and Caltrans Standard Specification Section 26, Aggregate Bases. Compact to ninety five percent (95%) minimum relative density.

C. Surface Preparation: Roll the aggregate base course until entire surface is firm, dense, and free from rock pockets and mud pads; do not slurry the base course. Clean the surface of all loose and extraneous material.

D. Water the base course after compaction.

E. Tolerances: Finish all surfaces to the following tolerance:

1. Aggregate Base Course: Plus 0.00 feet to minus 0.10 feet from line and grade shown on the Drawings.

END OF SECTION

SECTION 321300

RIGID PAVING

PART 1 - GENERAL

1.1 SUMMARY

- A. Section Includes: All labor, materials, equipment, tools, accessories, transportation, and services as required for concrete within the ADA Improvements scope only, including: :
 - 1. CIP Concrete walkways
 - 2. Curb and gutter
 - 3. Handicap ramps and driveways
 - 4. Other miscellaneous concrete items as they appear on plans

- B. Related Requirements
 - 1. Section 032000, Concrete Reinforcing
 - 2. Section 033000 Landscape Cast In Place Concrete (for CIP concrete work in the All-Inclusive Playground scope)
 - 3.
 - 4. Section 129300, Site Furnishings
 - 5. Section 312200, Grading
 - 6. Section 321100, Base Courses
 - 7. Section 334000, Storm Drainage Utilities

1.2 PRICE AND PAYMENT PROCEDURES

- A. Refer to City of Cupertino Project Manual.

1.3 REFERENCES

- A. Definitions
 - 1. Exposed to View: Situated so that it can be seen from eye level from a public location. A public location is that which is accessible to persons not responsible for operation or maintenance of project site.

- B. Reference Standards
 - 1. Geotechnical report: Geotechnical Evaluation, Jollyman Park All-Inclusive Playground, Ninyo & Moore Geotechnical & Environmental Sciences Consultants, February 18th 2022.
 - 2. Applicable ASTM Specifications as they reasonably apply to this work.
 - 3. ACI current standards.
 - 4. City of Cupertino General Conditions

- C. Caltrans Standard Specifications, 2022
 - 1. Section 39: Asphalt Concrete
 - 2. Section 73: Concrete Curbs and Sidewalks
 - 3. Section 88: Engineering Fabrics

4. Section 90: Concrete
5. Section 92: Asphalt Binder
6. Section 94: Asphaltic Emulsions
7. Section 96: Geosynthetics

1.4 ADMINISTRATIVE REQUIREMENTS

A. Notification

1. Notify other crafts so they may deliver anchors, inserts, etc., or other material required to be embedded in concrete.
2. Notify the City's Representative in writing at least forty-eight hours in advance of each concrete placement. The City's Representative will notify the geotechnical engineer and testing laboratory to order out the necessary concrete technicians to cover the work.
3. Once the concrete technicians are ordered out and a cancellation follows, the Contractor will be charged \$300 dollars for each technician so ordered to appear, unless a cancellation order is issued to the Laboratory by 3:00 pm the day before the concrete placement.
4. During the placement of the concrete, notify the City's Representative immediately of any delay at the concrete plant or at the job site. Do not mix concrete or add admixtures unless the Technician is present as per the Building Code.

- B. Sequencing: The Contractor shall notify the City's Representative at least forty eight (48) hours prior to placing any concrete. No concrete shall be placed in any unit of work until all form work and shoring has been constructed and all reinforcements and items to be built into concrete have been placed and secured and approved by the City's Representative.

1.5 SUBMITTALS

A. Product Data

1. Submit manufacturer's information for the following:
2. Admixtures
3. Curing compounds
4. Bonding agent
5. Reinforcing bars
6. Expansion joint filler
7. Expansion joint sealant
8. Embedded items
9. Exposed aggregate
10. Color pigments

B. Shop Drawings

1. Refer to Administrative Requirements, Section 013000.
2. Immediately after award of Contract, prepare shop drawings showing all fabrication dimensions and locations for placing of the reinforcing steel and accessories. Follow detailing recommendations of ACI 315. Shop drawings are to be prepared by a rebar detailer.
3. Do not order or deliver reinforcement to job site prior to approval of the shop drawings.

C. Samples

1. A 4'x4' sample of each concrete finish for paving and curbs shall be poured and finished at the site for City's Representative review prior to commencing concrete pouring. Once the samples have been reviewed, the Contractor shall meet or exceed that quality of finish in all subsequent work. Contractor shall be responsible for removal of the samples at the completion of the work.
2. Color Samples: If used, a 4'x4' sample of each concrete color for paving and curbs is required for review by the City's Representative.
3. Once samples have been reviewed and approved in writing by the City's Representative, the Contractor shall meet or exceed the quality of finish in all subsequent work.

D. Quality Control

1. Design Data: Submit design mixes for concrete, including list of admixtures to be used, to the Testing Laboratory and the City's Representative. After approval and prior to placement, send the approved mix to the Testing Laboratory. Provide compressive strength history for all concrete mixes. Strength history shall be within one (1) year of proposed use.

E. Certificates

1. Cement and Aggregate: Furnish to the City's Representative the following data:
2. Mill certificates from cement manufacturer certifying that cement meets ASTM specification and is suitable for purpose intended.
3. Proof of aggregate's compatibility with cement to be used and certification that aggregates meet ASTM specification. City reserves the right to have his testing laboratory perform additional tests on cement and aggregates which may be deemed advisable.
4. MEA approval for the admixtures and cement used.
5. Concrete producer's certificate must be presented at site before concrete is placed in accordance with 2000 IBDC with current California State Amendments. Also to be submitted to the Planning, Building & Code Enforcement Department.
6. The Contractor's superintendent's (the person supervising the concrete work) affidavit that all items have been installed as per the documents. Also to be submitted to the Planning, Building & Code Enforcement Department.

F. Test and Evaluation Reports

1. Compression Tests: If any test report indicates twenty eight (28) day specimen below required strength and if requested by the City's Representative, the Contractor shall take test cores of hardened concrete in accordance with ASTM C-42 Specifications. Test cores not meeting applicable ASTM standards shall deem the concrete defective. All concrete shown to be defective shall be removed and replaced. Cost of test cores, repairs, removal, and replacement of defective concrete shall be paid for by the Contractor.
2. Inspection: All concrete and other related work shall be inspected by the City's Representative or his representative. Notify the City's Representative at least forty eight (48) hours prior to placing any concrete.

1.6 QUALITY ASSURANCE

- A. Concrete Final Finishes: The Contractor shall demonstrate to the satisfaction of the City's Representative that they, or their subcontractor, possesses sufficient skills and experience to perform the work. Photographs and/or site visits of past work may be required to supply this information.

1.7 DELIVERY, STORAGE, AND HANDLING

- A. Materials: Attention is directed to Section 6, Control of Materials, of the Caltrans Standard Specifications and these Special Provisions. All materials required to complete the work under this contract shall be furnished by the Contractor.

1.8 WARRANTY

- A. Final Guarantee: Contractor shall provide guarantee according to City of Cupertino General Conditions.

PART 2 - PRODUCTS

2.1 RIGID PAVING EQUIPMENT

- A. Description: Conveying equipment shall be adequate in size and capacity as practicable to avoid re-handling or flowing. Conveying equipment shall be adequate in size and capacity to handle the work efficiently and shall be thoroughly cleaned before each pouring session.

2.2 RIGID PAVING MATERIALS

- A. Rough Formwork: Shall be Commercial Douglas Fir, DFPA: five eighth inch (5/8") thick minimum.
- B. Release Agent: VOC compliant material such as those of the Cresset Chemical Company for coating forms.
- C. Form Ties: Wire ties not permitted. Form ties for exposed concrete shall be adjustable, leave no metal closer than one and one half inches (1-1/2") to the surface, and free of devices which leave holes or depressions larger than seven eighths of an inch (7/8") back of exposed surface.
- D. Supports for Reinforcement: Support for reinforcement supported by ground shall be coated wire bar supports or bar supports made of dielectric material or other acceptable materials or precast concrete block, four square inch (4 sq in.) minimum, having a compressive strength equal to that of the concrete being placed. Wire bar supports shall be coated with dielectric material for a minimum distance of two inches (2") from the point of contact with the epoxy-coated reinforcing bars.
- E. Cement: All cement shall be Portland cement conforming to ASTM C-150, Specifications for Portland Cement and as per Section 90, Portland Cement Concrete of the Caltrans Standard Specifications. All concrete shall be Class A.
- F. Admixtures
 - 1. The use of admixtures shall comply with the requirements of paragraph 27-608 of the Building Code. The final soluble chloride content in concrete, percent by weight of cement, due to the addition of admixtures and other ingredients shall not exceed 0.05 at twenty eight (28) days.
 - 2. Air-entraining admixtures shall conform to ASTM C-260.

3. Chemical admixtures shall conform to ASTM C-494.
 4. Slag cement: ASTM C-989, Grade 100 or 120. The amount of cement required by the Building Code may be reduced by eight percent (8%) as per the code with the use of slag cement that has been reviewed and approved by the City.
 5. Color Additive:
Where shown on drawings as concrete, color is to be natural grey, or without color, with the addition that concrete paving shall include 1.5lb. of lampblack per cubic yard. Submit type for approval.
- G. Water: Shall be clean, potable water free from impurities detrimental to concrete and shall conform to the Section 90 Caltrans Standard Specifications.
- H. Concrete Aggregate
1. Concrete aggregate shall conform to Section 90, Portland Cement Concrete, of the Caltrans Standard Specifications as it applies to this Project.
 2. Maximum Size of Aggregate for Various Portions of the Work: The maximum size of the aggregate shall not be larger than one fifth (1/5) of the narrowest dimension between the forms of the members for which the concrete is used or larger than three fourths (3/4) of the clear space between reinforcing bars.
- I. Curing Method: Shall be as specified in Section 90, Portland Cement Concrete, of the Caltrans Standard Specifications.
1. Clear Curing and Sealing Compound (A.I.M. Regulations – VOC Compliant, 350 g/l): Liquid type membrane-forming curing compound, clear styrene acrylate type, complying with ASTM C1315, Type I, Class A, twenty five percent (25%) solids content minimum. Moisture loss shall be not more than 0.40 Kg/m² when applied at three hundred square feet (300 sq. ft.) per gallon. Manufacturer's certification is required.
 2. Curing Compounds shall be "Super Diamond Clear VOX" by The Euclid Chemical Company or "Masterkure 100W" by Master Builders.
- J. Bonding Agent
1. Epoxy/acrylic resin that will not form a vapor barrier with the concrete with the following properties:
 2. Bond strength of 1800 psi in two (2) hours when tested in accordance with ASTM C-882.
 3. Flexural strength of 2000 psi in twenty eight (28) days when tested in accordance with ASTM C-78.
 4. Tensile strength of 600 psi in twenty eight (28) days when tested in accordance with ASTM C496.
 5. Bonding agent shall be "CR246 Sto Bonding and Anti-corrosion Agent" by Sto Concrete Restoration Division or Armatec 110 by Sika Corp.
- K. Expansion Joints: Shall be as shown on plans and typical details
- 2.3 SOURCE QUALITY CONTROL
- A. Testing
1. The Testing Laboratory must be present when the concrete is being placed.
 2. Sample every one hundred and fifty (150 CY) cubic yards or each pour. Sample for seven (7) day and twenty eight (28) day compressive strength.
- B. Maintain the same brand, type, and source of cement throughout the project.

- C. Obtain aggregate from source with proven history of successful use. Source shall remain constant throughout the project unless approved by the City's Representative. Submit notice ten (10) days prior to changing source to allow for new mix design.

PART 3 - EXECUTION

3.1 EXAMINATION

A. Ambient Conditions

1. Cold Weather: Concrete shall not be placed when the atmospheric temperature is below forty degrees Fahrenheit (40oF) or when conditions indicate that the temperature will fall below forty degrees Fahrenheit (40oF) within seventy two (72) hours. Concrete when deposited shall have a temperature of not less than sixty degrees Fahrenheit (60oF). All reinforcement, forms, and ground which concrete will be in contact with shall be completely free of frost. The concrete and form work must be kept at a temperature of not less than fifty degrees Fahrenheit (50oF) for not less than seventy two (72) hours after pouring.
2. Hot Weather: Concrete shall not have a placing temperature higher than eighty five degrees Fahrenheit (85oF). All concrete shall be delivered to the forms at the coolest temperature practicable. Crushed ice, in lieu of mixing water, may be used to maintain the temperature. Concrete shall not be placed, when in the opinion of the City's Representative, the sun, heat, wind, or humidity will prevent proper placement and consolidation.

B. Verification of Conditions

1. Prior to placement of concrete, verify that the concrete cover over the reinforcement is that specified on Drawings.
2. Verify that reinforcement and all other embedded items are provided and held securely, positioned accurately, and will not be a detriment to concrete placement.
3. Examine all adjoining work on which this Work is in anyway dependent for proper installation and workmanship. Report to the City's Representative any condition that prevents the performance of this Work.
4. Verify that the subgrade and/or aggregate base is properly compacted and at suitable grade.

3.2 PREPARATION

A. Protection of In-Place Conditions

1. Protect all exposed surfaces, including flatwork, as required to protect the work from damage by impact, stains from rubbish, and work from other trades. Damaged surfaces shall be replaced at no added cost to the City.

B. Surface Preparation

1. Clear area to be paved of all debris and organic material. Recompact and regrade as necessary prior to placement of concrete.

- C. Grade Control: Establish and maintain the required lines and grades, including cross-slope during construction operations. All concrete shall slope to drain with no ponding of water.

3.3 INSTALLATION

A. Formwork

1. Provide formwork wherever necessary to confine concrete to the required shapes shown on Drawings. Follow all procedures ACI 301 and ACI 347. Formwork, reinforcement, and embedded items shall be clean of all accumulated mortar from previous concreting and other foreign material. Repair or replace any formwork as required.
2. Attention to Forms: Strengthen any portion of framework that may show deflection or movement of any nature. Any deflection or movement of forms which may cause variation in the concrete lines will be considered cause for rejection of the concrete work affected. All form work and material shall be inspected and approved by the City's Representative prior to pouring of any concrete.
3. Cover the surfaces of the rough formwork with an approved form release agent that will effectively prevent absorption of moisture, prevent bond with the concrete, and which will not stain the concrete surfaces. Do not apply oil or release agents on formwork for concrete to receive additional concrete (such as at construction joints). Apply at a rate that will help achieve the finish specified below. Follow manufacturer's recommendations.
4. Adequately support and substantially brace formwork to hold lines and shape. Securely brace forms against lateral deflection. Formwork shall be tight jointed to prevent leakage of concrete.
5. Place chamfer strips in the corners of forms to produce beveled edges (chamfers) on permanently exposed surfaces.
6. Provide "Rough Form Finish" for surfaces not exposed to view. Use plywood or metal forms coated with a release agent.
7. Provide "Smooth Form Finish" for surfaces exposed to view and the elements. Use dress, square-edged lumber with form liner or overlaid plyform forms with applicable release agent. Do not exceed manufacturer's recommendations for number of re-uses for the form liner or overlaid plyform. Arrange the forms or form liner in an orderly and symmetrical fashion, keeping the number of seams to a practical minimum.
8. Remove forms in such a manner as to assure the complete safety of the structure. Formwork not supporting the weight of the concrete may be removed as soon as the concrete has hardened sufficiently to resist damage from removal operations and as required by #9 below.
9. When repair of surface defects or finishing is required at an early age, remove forms as soon as the concrete has hardened sufficiently to resist damage from removal operations.

B. Mixing

1. Mixing of Concrete: All mixing shall conform to Section 90, Portland Cement Concrete of the City Standard Specifications as it applies to this project.
2. All Concrete Placed for Flat Work Shall Be Transit Mixed Concrete: Transit mixed concrete shall conform to ASTM C-9467. The rate of delivery, haul time, mixing time, and hopper capacity shall be such that all mixed concrete delivered shall be placed in the forms within ninety (90) minutes from the time the cement and water are introduced into the mixer. Any interruption in placing in excess of ninety (90) minutes will be cause for shutting down of the work for the day and the wasting of any remaining concrete in hoppers and mixers. In case such interruptions occur, the Contractor shall provide construction joints where and as directed by the City's Representative. Cut concrete back to such line. Construction joints shall be as detailed in the plans.

- C. Conveying Concrete: Concrete shall be conveyed as rapidly as practicable from the mixer to the place of final disposition without separation or loss of ingredients. It shall be conveyed as close to the final location as practicable to avoid re-handling or flowing.
- D. Placing Concrete: Reinforcing or other material that has been set shall not be disturbed. Before placing concrete, all forms, except sealed forms, shall be thoroughly soaked with water. All moldings and wood strips shall be soaked to prevent swelling and probable ensuing spilling of concrete. Concrete shall be placed in a manner that will prevent damage to, or displacement of, forms, reinforcing, pipes, etc., that are to be contained in the concrete.
- E. Construction Joints: Location and details of construction joints shall be as approved by the City's Representative.
1. All construction joints shall be well roughened, keyed, and thoroughly cleaned or broomed, so as to remove all dirt and laitance, and saturated with water before commencement of pour.
 2. Make joints not shown on Drawings at locations that will least impair the strength of the structure. Such location is subject to the approval of the City's Representative.
 3. Continue reinforcement across joints. Provide longitudinal keys at least one and one half inches (1-1/2") deep in walls and provide other keys as required.
- F. Expansion Joints
1. Do not extend reinforcement or other embedded metal items bonded to concrete continuously through expansion joint. Provide smooth dowels greased on one end at the joints or insert into PVC sleeve of length greater than the dowel length by three fourths inch (3/4") minimum.
 2. Provide expansion joint filler at the joint of the sizes indicated on the Drawings or specified herein.
- G. Embedded Items
1. Place all railing sleeves, shoes, and other embedded items required for the Work of other Divisions or for their support prior to concreting.
 2. Provide ample notice and opportunity for items of other Division to be introduced and/or furnished for installation before concrete is placed. Coordinate the Work of the other Divisions so all items are placed in their proper location.
 3. Set metal pipe sleeves, sockets, shoes, etc. into concrete to receive fence posts or any other items, all as indicated on details.
- H. Impressions: No impressions for advertising of Contractor name or other messages shall be impressed in any concrete.
- I. Finishes
1. Slope pavements uniformly toward drains, as shown on the Grading Plan. If pitch or elevations are not shown on Drawings, provide a minimum of one eighth inch (1/8") per foot.
 2. Finish pavement surface to a true smooth plane and texture with a toothed roller or float with a wood float. Score concrete pavement in squares of approximately five feet (5'-0") and/or as shown on Drawings. Each rectangular slab shall have all edges neatly rounded with proper tools and be bounded on all sides by a toveled border about one inch (1") in width.
 3. Level ramp, step and driveway surfaces with wood float and follow with finish noted on plans.

4. Medium Sandblast: Provide a uniformly textured medium sandblast finish to expose the sand particles in the mix. Sample finish shall be reviewed prior to pouring the concrete.
 5. Broom Finish: Provide a light broom finish with strokes perpendicular to direction of travel along walks.
 6. Trowel Finish: Smooth, parallel to longest surface direction.
- J. Waterproofing: Apply to wall as shown on drawing per manufacturer's instructions.
- K. Patching and Bonding to Existing Concrete
1. Provide bonding agent whenever new concrete is to be poured against existing concrete, whenever the time between concrete pours is longer than that allowed for proper bond, and wherever bonding agent is indicated on the Drawings to be applied.
 2. Remove loose concrete from surface to be bonded with new concrete and clean. Remove rust from reinforcement and structural steel by power chipping and power driven brushes.
 3. Apply bonding agent in accordance with manufacturer's specifications. Pour concrete as soon as bonding agent has cured and within twenty four (24) hours after placement. If the twenty four (24) hour period has elapsed, then the bonding agent must be reapplied.

3.4 SITE QUALITY CONTROL

- A. Inspections
1. After forms are removed, the City's Representative shall inspect all concrete surfaces. All surface defects, including projecting fins, rock pockets, honeycombs, foreign matter, cracks, and holes shall be filled and patched. Bolts, wires, nails, form ties, etc., extending from the face of the exposed concrete surfaces shall be cut off at least one inch (1") deep in the concrete immediately after removal of forms.
 2. Patching: Fill holes with a one part to three parts (1:3) mixture of cement and sand mortar, the same color as the adjoining concrete. Mix and place mortar as dry as practicable, and finish flush with adjacent surface. All patching and corrective work shall be done at the Contractor's expense to the satisfaction of the City's Representative. Concrete surfaces so repaired shall duplicate the appearance of the unpatched surfaces.
 3. The limits of all units of pour shall be approved by the City's Representative, before any concrete is placed. The unit of operation selected for continuous pouring and the location of construction joints shall be such as to least impair the strength and appearance of the various sections.
- B. Non-Conforming Work
1. Defective work, such as under strength of concrete, surface out of line, level, or plumb, excessive cracks, honeycomb, rock pockets, voids, exposed reinforcing, etc., shall be repaired, removed, and replaced by the Contractor as directed and to the satisfaction of the City's Representative at no cost to the City.
 2. All concrete work which is not true to line and plane, not conforming to specified finishes, exceeds tolerances, does not slope to drain, improperly cured, and others not conforming to plans as specified herein shall be deemed defective.
 3. All such defective work shall be removed and replaced with proper work meeting plans and specifications requirements at no cost to the City.

3.5 PROTECTION

A. Curing

1. General
2. Begin curing concrete immediately after placement and finishing. Protect all freshly deposited concrete from premature drying and excessively hot or cold temperatures and maintain it with minimal moisture loss at a relatively constant temperature for the period of time necessary for the hydration of the cement and proper hardening of the concrete. Detailed procedures are given in ACI 308.
3. Do not apply curing compounds to surfaces receiving additional concrete. Provide only wet curing.

B. Procedure

1. Concrete surfaces not in contact with forms:
2. Ponding or continuous non-manual sprinkling
3. Absorptive mat or fabric, sand, or other covering kept continuously wet.
4. Curing compounds conforming to ASTM C-309, C-1315.
5. Concrete surfaces in contact with forms:
6. Minimize moisture loss from forms exposed to heating by the sun by keeping forms wet until they are removed.
7. After form removal, cure with one of the methods listed in #1 above.
8. Continue curing until a total of seven (7) days has elapsed during which the temperature of the air in contact with concrete has remained above fifty degrees Fahrenheit (50°F). Prevent rapid drying during and at the end of the curing period.

C. Cold Weather Curing

1. Concrete must be protected from water loss. This shall be accomplished by the application as soon as possible without harm to the concrete surfaces of either (a) exhaust steam, or vapor-resistant paper or polyethylene film, or (b) curing compounds. In all other respects, curing shall conform to applicable provisions of this Section. Concrete temperature shall be maintained between fifty degrees Fahrenheit (50°F) and seventy degrees Fahrenheit (70°F).

D. Hot Weather Curing

1. During the period June 1 to October 1 or when hot weather conditions require it, maintain continuous water curing for a minimum period of twenty-four hours. Provide for wind breaks, shading, and other necessary provisions.
2. After twenty four (24) hours, curing shall be by one of the methods specified under B above. In all other respects, curing shall conform to applicable provisions of this Specification. Upon termination of the specified moist curing, every effort should be made to reduce the rate of drying by avoiding air circulation.

- E. During the curing period, and thereafter as conditions may require, protect the concrete from damaging mechanical disturbances, particularly excessive load stresses, heavy shock, and excess vibration. Protect all finished concrete surfaces from damage caused by construction equipment, materials or methods, and by rain or running water.

END OF SECTION

SECTION 32 15 40

DECOMPOSED GRANITE PAVING

PART 1 - GENERAL

1.01 SUMMARY

- A. Section Includes: All labor, materials, equipment, tools, accessories, transportation, and services as required for Decomposed Granite Paving.
- B. Related Requirements
 - 1. Section 31 22 00, Grading
 - 2. Section 32 11 00, Base Courses

1.02 PRICE AND PAYMENT PROCEDURES

- A. Refer to City of Cupertino Project Manual.

1.03 REFERENCES

- A. Standards: Comply with pertinent provisions of following standards, in case of conflict between referenced standards, the more stringent requirements shall govern.
 - 1. ASTM, latest edition.
 - 2. AASHTO Specifications for Materials, latest edition.
- B. Standard Specifications: Conform to all applicable requirements of the Standard Specifications listed below, whether specifically referred to or not, except as modified hereinafter.
 - 1. CalTrans Standard Specifications.

1.04 ADMINISTRATIVE REQUIREMENTS

- A. Scheduling
 - 1. Inspection: The City will determine the location, timing, and number of compaction tests to assure that specified requirements are met.

1.05 SUBMITTALS

- A. Product Data
 - 1. Soil Sterilant: Submit written recommendation from a State of California appropriately licensed individual along with complete product data from proposed manufacturer, for review by Engineer.
 - 2. Decomposed Granite
 - a. Sieve analysis of aggregate materials.
 - b. Manufacturer's specifications and other data needed to prove compliance with the specified requirements.
 - c. Certificates of compliance with the specified standards for natural materials and manufactured items.
 - 3. Material list of items proposed to be furnished under this section.
- B. Samples
 - 1. Decomposed Granite Paving without stabilizer: Contractor shall submit a 5 lb. sample of decomposed granite to the Engineer for approval prior to delivery of material to the site.
 - 2. Decomposed Granite Paving with stabilizer: Contractor shall submit a 5 lb. sample of decomposed granite and 1 lb. stabilizer to the Engineer for approval prior to delivery of material to the site.
 - 3. The Contractor shall demonstrate to the satisfaction of the Engineer that he or his subcontractor possesses the skills to perform the work in all aspects required.

4. A five-square-foot sample of decomposed granite paving shall be installed at the site for the Engineer’s review and approval. The Contractor shall meet or exceed that quality of work in all subsequent work. Contractor shall be responsible for the removal of the sample at the completion of work.

1.06 QUALITY ASSURANCE

A. Tests and Inspections

1. The City will provide a qualified testing laboratory to observe and test placement of aggregate in accordance with the specifications.
2. Tests will include inspection of subgrade prior to placing aggregate, inspection and testing of materials after mixing, and compaction tests to determine compliance with specification requirements.

B. Grading Tolerance: Construct grades described in this section within a tolerance of plus or minus five hundredths (0.05) foot maximum variation in any ten foot length from the grades shown on drawings.

C. Surface Drainage: No area of the finished paving will hold water.

D. Qualifications of Workers: Provide at least one person who shall be thoroughly trained and experienced in the skills required, completely familiar with the design and application of work described for this section and present at all times during progress of the work of this section and direct all work performed under this section.

1.07 DELIVERY, STORAGE, AND HANDLING

A. Materials: Attention is directed to the City of Cupertino Project Manual. All materials required to complete the work under this contract shall be furnished by the Contractor.

1.08 SITE CONDITIONS

A. Protection from Water Accumulation: Perform all operations in a manner which continuously allows proper disposal of surface run-off and prevents accumulation of water potentially causing soft areas impeding Work. Before leaving after each work day perform such operations as may be necessary to minimize possible damage or work slowdown caused by rain.

1.09 WARRANTY

A. Final Guarantee: Contractor shall provide guarantee per Section 7-1.23, Final Guarantee of the City Standard Specifications.

PART 2 - PRODUCTS

2.01 DECOMPOSED GRANITE PAVING

A. Description: Shall be California gold track fines.

B. Performance

1. Without Stabilizer

Sieve Size	% Passing
#4	95 -100
#30	30-50
#200	5-15

- | | |
|--------------------|-----------|
| 2. With Stabilizer | |
| Sieve Size | % Passing |
| #4 | 85-100 |
| #8 | 55-80 |
| #30 | 30-45 |
| #200 | 10-20 |
3. Maximum dry density: 130 p.c.f.
 4. Optimum moisture: 8.8%
 5. Color: Shall be uniform tan or buff color.
 6. The performance characteristics of the decomposed granite should not be impacted by minor variations of the gradation ($\pm 10\%$).

2.02 STABILIZER

A. Manufacturers

1. Stabilizer Solutions of Phoenix, Arizona (1-800-336-2468) or approved equal as supplied by Supply Side Products (888) 222-4341 or approved equal.

B. Description

1. Stabilizer™ binder additive. The organic binding agent shall be a premium non-toxic, colorless, odorless, non-staining concentrated powder that binds decomposed granite together to provide a natural appearing firm surface.

PART 3 - EXECUTION

3.01 PREPARATION

A. Protection of In-Place Conditions

1. Surrounding areas, surfaces and appurtenances already in place shall be protected during installation of decomposed granite paving.

B. Surface Preparation

1. Prior to any installation, the area shall be treated with weed control treatment and pre-emergent treatment.
2. Immediately prior to placing the decomposed granite, the subgrade shall be moistened.

C. Mixing

1. The binding agent shall be premixed at a standard rate of twelve to sixteen pounds (12-16 lbs.) per ton of decomposed granite. It is critical that Stabilizer be thoroughly and uniformly mixed throughout the decomposed granite.
2. Perform blending by the stationary plant method or a truck mounted mixer.
3. Portable mixers may not be used.
4. Mixing granular surfacing and stabilizer in situ is not acceptable.
5. Do not mix during, just prior to, or immediately following rainfall.
6. Blend for a minimum of 15-minutes.

3.02 INSTALLATION

A. DECOMPOSED GRANITE PAVING

1. Decomposed granite shall be as shown and detailed on the Plans and be approved by the Engineer, both to color and gradation.
2. Upon thorough moisture penetration, compact aggregate screenings to ninety five percent (95%) relative compaction by compaction equipment such as double drum roller (2-4 ton) or single drum roller (1,000 lbs.) vibratory plate tamp. Do not begin compaction for six (6) hours after placement and up to forty eight (48) hours.

3. Decomposed granite shall be installed in two inches (2") lifts compacted to a four inches (4") depth. Each lift shall be wetted, rolled, and compacted to ninety five percent (95%) relative density.
4. In general each layer shall be placed in spreads as wide as practicable and to the full width of the course before a succeeding layer is placed.
5. Installation of decomposed granite shall not occur on rainy days.
6. Fill in any low spots or cracks with additional decomposed granite.
7. Grade to smooth uniform slopes between elevation points or lines, and between such elevations and existing grades.
8. Tolerances: The finish grades of the decomposed granite paving shall conform to the lines and grades on the drawings and allow for drainage.
9. Finish rake granular surfacing smooth with a steel tine rake.
10. Final thickness of the completed path section shall not vary more than ½-inch from the dimensions indicated.

B. Watering

1. Water heavily to achieve full depth moisture penetration of the granular surfacing to activate entire depth of stabilizer. Apply minimum of twenty (20) GPM per one thousand square feet (1,000 sf) for a one hour duration.
2. Spray water in such a manner as to not disturb the path surface.
3. Test for depth of water penetration by random inspection of pavement cores. Following inspection fill holes with removed material and smooth to match adjacent surfacing.
4. Let watered surface stand for six to twenty four (6-24) hours until surface water is no longer present and the granular surfacing is moist but not wet.
5. Fill in any low spots or cracks with additional decomposed granite.

C. Compaction

1. While granular surfacing is still thoroughly moist, roll with a heavy lawn roller (minimum two hundred and twenty five pounds (225 lbs.) and maximum width of thirty inches (30") to achieve finish grade and initial compaction.
2. Hand tamp edges and areas inaccessible to the roller.
3. Perform final compaction with a minimum 1-ton roller to achieve a dense, smooth, uniform surface texture.
4. Do not use whackers or vibratory rollers as the granular surfacing will not harden for weeks.

3.03 SITE QUALITY CONTROL

A. Non-Conforming Work

1. Remove and replace decomposed granite paving that is damaged, defective, or does not meet requirements of this section.

B. Site Tests and Inspections

1. Finished surface shall be smooth, uniform and solid, with no evidence of chipping or cracking. Dried, compacted surfacing shall be firm all the way through with no spongy areas.
2. Loose material shall not be present on the surface prior to extensive use.
3. Loose and unconsolidated material is evidence of improper bonding due to poor mixing or insufficient watering. Test the loose material for adequate stabilizer by wetting, then tamping and allowing it to dry. If the material is still unconsolidated, the stabilizer did not get mixed adequately throughout the surfacing. If the material now is solid, initial watering was insufficient, cracking or sponginess is evidence of excessive stabilizer in the mix.
4. Remove all unconsolidated surfacing material and replace in accordance with the pertinent requirements of this section.

3.04 CLEANING

- A. Planting Areas: All excess decomposed granite shall be removed from planting areas.

3.05 PROTECTION

- A. General: Following construction of each layer and following completion of the decomposed granite paving take all required measures necessary to prevent or repair segregation, raveling or rutting, and to maintain the layer in the specified condition until it is covered with a following layer or until all work is completed.
- B. Final Acceptance: Immediately prior to final acceptance smooth any irregularities by rewetting rough areas thoroughly and rolling with one thousand to one thousand five hundred pound (1000-1500 lbs.) roller.

END OF SECTION

SECTION 32 18 16

PLAYGROUND PROTECTIVE SURFACING

PART 1 - GENERAL

1.1 SUMMARY

- A. Furnishing, delivery, installation and warranty of complete safety surfacing systems including drainage, cushion layer, top layer, and infill material.
- B. Section Includes:
 - 1. Poured-in-Place Rubber Safety Surfacing ("PIPSS")
 - 2. Synthetic Turf Safety Surfacing ("STSS")
 - 3. Play Sand
- C. Related Documents and Sections:
 - 1. City of Cupertino Project Manual
 - 2. Section 11 68 00 - Playground Equipment
 - 3. Section 32 11 00 – Base Courses
 - 4. Section 32 13 00 – Rigid Paving

1.2 PRICE AND PAYMENT PROCEDURES

- A. Refer to City of Cupertino Project Manual

1.3 DEFINITIONS

- A. Critical Height: Standard measure of shock attenuation. According to CPSC No. 325, this means "the fall height below which a life-threatening head injury would not be expected to occur." Also called Fall Height.
- B. Use Zone: According to ASTM F 1487, "the area beneath and immediately adjacent to a play structure that is designated for unrestricted circulation around the equipment and on whose surface it is predicted that a user would land when falling from or exiting the equipment." Also called Play Safety Zone.

1.4 REFERENCES

- A. Reference Standards
 - 1. Department of Justice 2010 American Disabilities Act Standards for Accessible Design ('2010 ADA').
 - 2. Department of Justice Title II regulation of ADA (28CFR Part 35)

3. Department of Justice Title III regulation of ADA (28 CFR Part 36)
4. U.S. Consumer Product Safety Commission ('CPSC publication #325'): Public Playground Safety Handbook, latest edition.
5. ASTM F1487: Standard Consumer Safety Performance Specification for Playground Equipment for Public Use, latest edition.
6. ASTM F1292, Standard Specification for Impact Attenuation of Surfacing Materials Within the Use Zone of Playground Equipment, latest edition.
7. ASTM F1951: Standard Specification for Determination of Accessibility of Surface Systems Under and Around Playground Equipment, latest edition.
8. ASTM F2223: Standard Guide for ASTM Standards on Playground Surfacing, latest edition.
9. International Play Equipment Manufacturers Association ('IPEMA') Certification Service.

1.5 PERFORMANCE REQUIREMENTS

- A. Impact Attenuation: According to ASTM F 1292.
 1. Safety surfacing within playground equipment use zones shall meet or exceed the performance requirements of CPSC and ASTM F 1292 that a surface yield both a peak deceleration of no more than 200g, and a Head Injury Criteria (HIC) value of no more than 1,000 g, for a head-first fall from the highest accessible portion of play equipment being installed. The highest accessible portion of playground equipment shall be as specified in Section 116800 - Playground Equipment. **The Contractor is responsible for obtaining a determination from the safety surfacing manufacturer of the product depth required to meet performance requirements for all play equipment.**
- B. Accessibility of Surface Systems: According to ASTM F 1951, Standard Specification for Determination of Accessibility of Surface Systems under and around Playground Equipment.
- C. Additional ASTM standard test measures:
 1. D1577 – Standard Test Method for Linear Density of Textile Fiber
 2. D5848 – Standard Test Method for Mass Per Unit Area of Pile Yarn Floor Covering
 3. D418 – Standard Test Method for Testing Pile Yarn Floor Covering Construction
 4. D1338 – Standard Test Method for Tuft Bind of Pile Yarn Floor Coverings
 5. D1682 – Standard Method of Test for Breaking Load and Elongation of Textile Fabrics
 6. D5034 – Standard Test Method of Breaking Strength and Elongation of Textile Fabrics (Grab Test)
 7. F1551 – Standard Test Methods for Water Permeability
 8. D2859 – Standard Test Method for Ignition Characteristics of Finished Textile Floor Covering Materials
 9. F355 – Standard Test Method for Shock-Absorbing Properties of Playing Surfaces
 10. D1557 – Test Method for Laboratory Compaction Characteristics of Soil Using Modified Effort.

1.6 SUBMITTALS

- A. MIG submittal requirements below to prevail over manufacturer's submittal list.
- B. Product Data: For each type of product indicated.
- C. Certificates of Compliance:
 - 1. Provide a statement, signed by an official authorized to certify on behalf of the synthetic turf safety surfacing manufacturer, attesting that the surfacing meets the requirements of ASTM F 1292 for a head-first fall from the highest accessible portion of installed play equipment. The impact attenuating qualities of the surfacing system shall not be diminished in the surface areas covering hardware. Testing of product shall include tests conducted over hardware. The statement shall be dated after the award of the Contract, shall state the Contractor's name and address, and shall name the project and location. The statement shall also provide the name, address, and telephone number of the testing company, the date of the test, and the test results.
 - 2. Provide certification by the authorized manufacturer's representative, upon completion of the installation, that the safety surfacing has been installed in accordance with manufacturer's instructions and complies with all specifications.
 - 3. Provide a Certificate of Insurance from the manufacturers of synthetic turf safety surfacing, covering both product and general liability, of not less than \$1,000,000. The issuing underwriter shall be AA rated.
- D. Shop Drawings: For each playground surface system, include materials, plans, cross sections, drainage, installation, penetration details, and edge termination including loose fill edgings. Include patterns made by varying colors of surfacing.
 - 1. Samples for Verification and Color/Product Selection:
 - a. For Poured in Place Rubber Safety Surfacing (PIPSS):
One pint sample of synthetic rubber granules showing color, manufacturer's test data identifying the critical height of material per specified base and wear course depths.
 - b. Synthetic Turf Safety Surfacing (STSS):
2 samples in standard "green," 12"x12" minimum size, illustrating details of finished product as bid, including full cross section of sub-base, turf and infill material
 - 2. Safety Surfacing Mix Samples for Verification:
 - a. Poured-in-Place Rubber Safety Surfacing (PIPSS):
Minimum 12"x12" Sample of synthetic rubber seamless surface, of each color specified, proposed for this project. Second round of samples/approval to be provided if first is not approved.
 - 3. Purchased Play Sand: Minimum 1-quart play sand sealed in a container.
- E. Product Schedule: For playground surface systems. Use same designations indicated on Drawings.
- F. Coordination Drawings (see also 11 68 00 Play Equipment): Plans, drawn to scale, on which the following items are shown and coordinated with each other, using input from Installers of the items involved:
 - 1. Overall Layout Plan, showing:
 - a. Critical heights for playground surface or fall heights for equipment
 - b. Extent of surface systems and use zones for equipment.
 - c. Depth and type of surface systems and any transitions between depths.

- d. Minimum dimensions from all obstructions, such as curbs and paving, to extent line of fall zones
 - e. Color locations
 2. Seaming plan.
 3. Method of attachment and Installation details; perimeter conditions and edge details, utility box detail, etc.
- G. Qualification Data: For qualified Installer and testing agency
- H. Material Test Reports: Based on evaluation of comprehensive tests performed by a qualified testing agency, for each loose-fill playground surface system.
 1. Submit a copy of product manufacturer's test report indicating compliance with the latest U.S. Consumer Product Safety Commission's Technical Guidelines for Public Playground Safety with regard to thickness of product beneath various equipment height ranges. Test reports shall be by a certified laboratory, to ASTM F 1292-99 specifications using the f355-Procedure C Test Method.
 2. For purchased sand, submit a statement signed by an official authorized to certify on behalf of the supplier of the sand, attesting that the surfacing material is free from poisonous plants, foreign objects, hazardous substances, or toxic chemicals. The statement shall be dated after the award of the contract, shall state the Contractor's name and address, and shall name the project and location.
- I. Product Certificates: For each type of unitary synthetic playground surface system, from manufacturer.
- J. Product Test Reports: Based on evaluation of comprehensive tests performed by a qualified testing agency, for each unitary synthetic playground surface system.
- K. Field quality-control reports.
- L. Maintenance Data: For playground surface system to include in maintenance manuals.
- M. Warranty: Sample of special warranty.

1.7 QUALITY ASSURANCE

- A. Manufacturer Qualifications:
 1. Company specializing in manufacturing products specified in this section.
 2. Materials other than those listed must be approved 15 days prior by written addendum. Materials from non-approved manufacturers will not be accepted.
 3. Must be experienced in the manufacturing of tall pile synthetic infill turf systems with the same fiber as specified.
 4. Manufacturer must be a member in good standing with the STC.
 5. Manufacturer must utilize best practices as certified by ISO-9001 and ISO-14001.
 6. Manufacturer must be owned and operated in the U.S.A.
 7. Manufacturer must have no periods of insolvency over the last 25 years.

B. Installer Qualifications:

1. Company specializing in performing the work of this section.
2. An employer of workers trained and approved by manufacturer, who are competent workmen skilled in this type of synthetic turf installation. Installation team shall be established, insured installation firm experienced as a premium turf installer with suitable equipment and supervisory personnel, with a minimum of 5 years' experience with 15-foot-wide tufted materials.
3. The Synthetic Turf (STSS) Installer and Pour in Place Rubber (PIPSS) Installer shall submit a listing of at least five (5) installations where products similar to those proposed for use have been installed and have been in successful service for a minimum period of three (3) years. This list shall include owner or purchaser; address of installation; service or maintenance organization; date of installation; contact person; and phone number of the contact person.
4. Prior to the beginning of installation, the Synthetic Turf (STSS) Installer and Pour in Place Rubber (PIPSS) installer shall inspect the subbase. The installer will accept the sub-base in writing when the general contractor provides test results for compaction, and planarity that comply with the synthetic turf manufacturer's recommendations and as stated herein.

C. Source Limitations: Obtain turf safety surface system materials, from single source from single manufacturer.

1. Provide secondary materials including adhesives, primers, geosynthetics, and repair materials of type and from source recommended by manufacturer of playground surface system materials.

D. Standards and Guidelines: Comply with current publications of CPSC No. 325, "Handbook for Public Playground Safety"; ASTM F 1292; and ASTM F 1487.

1.8 PROJECT CONDITIONS

- A. Weather Limitations: Install synthetic turf surfacing only when ambient air temperature is 35° F or above and the relative humidity is below 35% or as specified by the product manufacturer. Installation shall not proceed if rain is imminent.
- B. Sequencing and Scheduling: Safety surfacing shall be installed after the playground equipment is installed. The installation shall be coordinated with playground equipment and site element installation. Coordinate all work with the work of other sections to avoid delay and interference with other work.
- C. Protect excavations by shoring, bracing sheeting, underpinning, or other methods as required to prevent cave-ins or loose dirt from entering excavations. Barricade open excavations and post warning lights at work adjacent to public streets and walks.

1.9 WARRANTY

- A. Special Warranty: Contractor shall submit Manufacturer's standard form that has been completed in Owner's name and registered with the manufacturer. Manufacturer shall provide warranty as follows:

1. Minimum eight-year warranty policy by the manufacturer, against defects in materials and one year against defects in the workmanship. Defects shall include, but not be limited to:
 - a. Reduction in impact attenuation
 - b. Ultraviolet ray fading, degradation, or excessive wear of fiber
2. Warranty shall be for full replacement of any damaged product within the warranty period. Warranty shall be comprehensive and sufficient to replace all turf if necessary.
3. Warranty shall become effective from the date of substantial completion.
4. Warranty shall contain no usage limits for warranted turf.

PART 2 - PRODUCTS

2.1 CONCRETE SUB-BASE

- A. Only where indicated on Drawings per notes on Safety Surfacing details.

2.2 AGGREGATE SUB-BASE

- A. Per geotech report, at all locations not meeting the slope criteria to require Concrete Sub Base.

2.3 POURED-IN-PLACE-RUBBER SAFETY SURFACING (PIPSS)

A. Product and Manufacturer

1. Product: TotTurf Poured in Place (PIP) TPV Supreme (.5-1.5mm)
2. Manufacturer: Robertson Recreational Surfaces. Manufactured and installed by Robertson Industries Inc., or it's Certified Installers. Telephone: (800) 858-0519.

B. Performance Criteria

1. Capacities: Surfacing shall comply with current ASTM F-1292.

C. Finishes

1. See drawings for materials plan with locations of PIPSS.
2. Each area noted in the drawings will be a mixture of up to four colors of granules selected from the manufacturer's standard colors, and noted by percentages. Black shall not be used.
3. Color mixes shall be specified by the Landscape Architect in the submittal process, to be verified using samples provided by the Contractor (see Submittals Section).
4. A round of additional samples shall be provided if first samples do not meet City Representative's expectations and approval.
5. Binder shall be non-toxic, weather-resistant, UV-stabilized, alaphatic, flexible, nonhardening, 100 percent solids polyurethane complying with requirements of authorities having jurisdiction for nontoxic and low VOC content.

2.4 SYNTHETIC TURF SAFETY SURFACING (STSS)

A. Product and Manufacturer

1. Basis of design product is ForeverLawn - Playground Grass Ultra. Any alternates should be submitted through the City's standard process for review and approval and must match or exceed anti-static properties of basis of design product and meet City approval for color and texture.
2. Manufacturer: Forever Lawn, 8007 Beeson St., Louisville, OH 44641, phone 866.992.7876, playgroundgrass.com. National Rep / Playground Grass Brand Leader: Kevin Kinsey, kevin@foreverlawn.com, phone 330.499.8873 ext 335.
3. Local Forever Lawn Dealer and Installer: Jorge Prado, Forever Lawn Bay Area, 707.260.9948, Jorge@bayarea.foreverlawn.com
4. Syn. Turf Top Layer: Playground Grass Ultra
5. Impact Attenuating Cushion Course: ForeverLawn's (manufacturer) standard formulation for substrate cushion that shall meet requirements herein for impact attenuation. Foam rubber shall not be permitted in substrate. Use Safety Cel-type cushion for any areas with critical fall height of 10-feet or higher, as recommended by the manufacturer.
6. Provide manufacturer's standard thickness for each layer as required for overall thickness indicated by play equipment's critical height, tested for impact attenuation according to ASTM F 1292 and for accessibility according to ASTM F 1951.

B. Performance Criteria

1. Capacities: Surfacing shall comply with current ASTM F-1292.

2.5 INORGANIC LOOSE-FILL SURFACE: PLAY SAND

A. Inorganic aggregate materials: clean, washed, and free of loam, clay, organic matter, debris, and other foreign substances

1. Play Sand: Shall be washed, quarried, coarse-grained beach sand, such as 2/16 Amber Playground Sand, shall be dirt and salt free, and comply with ASTM C 136 for the following sieve analysis test results:
2. Sand shall conform to the following gradings:

Sieve Size	% Passing
#12	100
#16	87-95
#20	12-30
#30	0-4
3. Uncompressed Material Depth: As indicated on the drawings

PART 3 - EXECUTION

3.1 GENERAL

- A. Installation of the synthetic turf system is to comply with the Manufacturer's recommendations, requirements and the reviewed and approved shop drawings.
- B. Perform all work in strict accordance with the contract documents and the manufacturer's specifications and instructions. Only those skilled technicians proposed in the bid phase are to be assigned to this project by the Contractor.
- C. The designated Supervisor for the Synthetic Turf Installer must be present during all construction activity associated with the field installation, including testing, cleanup and training.
- D. All products and equipment are to be from sources approved by the authorized turf manufacturer and conform to the specifications.

3.2 SUB-BASE INSTALLATION AND SITE INSPECTION

- A. Verify that substrates are satisfactory for turf safety surface system installation and that substrate surfaces are suitably free of dirt, dust, and petroleum products, dry, cured, and uniformly sloped to drain within recommended tolerances according to playground surface system manufacturer's written requirements for cross-section profile.
- B. Finished Grade:
 - 1. Elevations of adjacent areas shall be as indicated on the Drawings and the safety surfacing manufacturer's directions. The appropriate subgrade elevation shall be as established for the specified safety surfacing to be installed.
 - 2. Contractor shall perform a site inspection, including a check for planarity. The finished surface shall not vary from a true plane more than 0.25" in 10' when measured in any direction. The Contractor shall provide all required tools and materials needed for the planarity check, which may include but not be limited to, a laser level, string line, straight edge and/or other assessment materials. The Contractor shall mark in the field any deviations from grade in excess of those specified above, as well as provide a marked-up plan locating the deviations. The Contractor shall correct any deviations to the satisfaction of the Engineer and Synthetic Turf Installer.
 - 3. Using a plate compactor, jumping jack or other vibratory compaction device, the aggregate base shall be compacted such that stone facets are properly oriented to achieve approximately 1" reduction in vertical height (about 8% settlement). Surface tolerances shall not exceed 0.25" over 10'. Base material shall be wetted during mixing operations, if necessary, for proper blending.
- C. The Contractor shall have a state registered surveyor conduct an elevation survey of the area in a 25' grid to determine and verify that subgrade elevations and slopes are within previously specified tolerances. This elevation survey may require further verification of smaller areas within the 25' grid if determined necessary by the Engineer.
- D. When any or all corrective procedures have been completed, the finished sub-base surface must be re-inspected, with the same representatives attending as the initial inspection. If

required, additional repair and inspections are to be conducted until the sub-base surface is deemed acceptable by the Engineer and Synthetic Turf Installer

- E. Once the sub-base surface has been deemed acceptable, the Contractor shall submit a written certificate indicating the acceptance of:
 - 1. The sub-base construction finished surface as totally suitable for the application of the selected synthetic turf system, and
 - 2. The sub-base construction as totally suitable for work under this section to proceed with the final installation and fully warrant the athletic surface installation for the period and conditions specified herein.
- F. Proceed with installation only after unsatisfactory conditions have been corrected. Commencement of work under this section shall constitute acceptance of the work completed under other sections by the Contractor, acceptance of dimensions of the sub-base, and hence, no claims for extra work based upon these conditions will be permitted.

3.3 PRODUCT DELIVERY, STORAGE & HANDLING

- A. Deliver products to site in original containers and wrappers as agreed between the Engineer and Contractor. Inspect products upon delivery for damage.
- B. Store products in a location and in a position, that protects them from crush damage or any other defects.
- C. Handle and store (on and off site) all materials safely to ensure their physical properties are not adversely affected and that they are not subject to vandalism or damage.
- D. Infill shall arrive dry and loose.
- E. Adhesives shall arrive in dry, sealed containers.

3.4 INSTALLATION - GENERAL

- A. The surfacing shall be constructed and installed in accordance with the manufacturer's specifications and with the details as shown on the plans and per applicable sections of these specifications.
- B. Playground Protective Surfacing intended to serve as accessible routes for persons with disabilities shall be firm, stable and slip resistant, and shall meet the requirements of 2010 ADA and ASTM F1951.

3.5 INSTALLATION - CUSHION LAYER

- A. Install cushion layer in accordance with the Manufacturer's written installation instructions.

3.6 INSTALLATION - PIPSS

- A. Substrate: Whenever practical, substrate layer of surfacing material shall be installed in one continuous pour on the same day. When a second pour is required, fully coat the edge of the previous work with polyurethane binder to ensure one hundred percent (100%) bond with new work. Apply adhesive in small quantities so that new substrate can be placed before the adhesive dries.
- B. Wear Surface:
1. The maximum thickness of the color wear surface shall be as shown on the details on the plans.
 2. The color wear surface shall be completed in one continuous pour with no seams or joints except where wearing surface is composed of differing color patterns.
 3. The color shall be consistent throughout the entire surface as shown on the plans.
 4. Wearing surface shall be bonded to substrate. Apply adhesive to substrate in small quantities so that wearing surface can be applied before adhesive dries.
 5. Surface shall be hand trowelled to a smooth, even finish.
 6. Where seams are required due to color change, a step configuration will be constructed to maintain wear surface integrity. The edge of initial pour shall be coated with adhesive and wearing surface mixture shall be immediately applied.
 7. Pads with multiple seams are encouraged to include a top coating of urethane before being placed into use.
 8. Butt joint seams are not acceptable.
 9. Under special conditions and with the City Representative's written approval, seams may be permitted in same color pad.
- C. Thickness: Construction methods, such as use of measured screeds one and one sixteenth inches (1-1/16") thicker than the required surfacing depth, shall be employed to ensure that full depth of specified surfacing material is installed. Playground Protective Surfacing system thickness throughout the playground equipment use zone shall be as required to meet the impact attenuation requirements specified herein.

3.7 TURF INSTALLATION - STSS

- A. Install synthetic turf system in accordance with the Manufacturer's written installation instructions.
- B. Turf shall be attached to the perimeter edge as shown in the construction plans and as per the manufacturer.
- C. All seams shall be brushed thoroughly before infill materials are installed.
- D. All terminations shall be as detailed and approved in the shop drawings.

3.8 INFILL INSTALLATION - STSS

- A. The synthetic turf shall be thoroughly brushed prior to installation of infill materials to remove wrinkles.
- B. Turf shall remain free draining at all times before, during and after the infill materials are installed.

3.9 FIELD QUALITY CONTROL

- A. Testing Agency: Engage a qualified testing agency to perform tests and inspections.
- B. Testing Services: Testing and inspecting of completed applications of playground surface system shall take place according to ASTM F 1292.
- C. Remove and replace applications of playground surface system where test results indicate that it does not comply with requirements.
- D. Non-Conforming Work:
 - 1. No subsequent layers of color surfacing shall be allowed to repair flaws, vandalism,
 - 2. If color and thickness is not consistent, the entire surface of the color coat shall be removed and replaced at the direction of the City Representative, at no additional cost to City.
- E. Additional testing and inspecting, at Contractor's expense, will be performed to determine compliance of replaced or additional work with requirements.
- F. Clean-up: Do not allow adhesives on adjacent surfaces. Immediately clean up spills or excess adhesive

3.10 CLEANING, REPAIRS AND PROTECTION

- A. Maintain all benchmarks, monuments, and other reference points. If disturbed or destroyed, replace as directed.
- B. Adjacent streets, sidewalks, and property shall be kept free of mud, dirt, or similar nuisances resulting from earthwork operations.
- C. Protect all installed work from other construction activities as installation progresses.
- D. The Contractor shall keep the area clean throughout the construction period and free from the installation process, including track surfaces.
- E. Upon completion of the installation, thoroughly clean surfaces and site of all refuse resulting from the installation process, including track surfaces.
- F. Any damage to existing fixtures or facilities resulting from the installation of the synthetic turf system shall be repaired to original condition at the Contractor's expense prior to substantial completion and commencement of the warranty period.

- G. A deficiency list will be produced by the Engineer at the conclusion of the project. All installation project deficiencies not in dispute must be remedied by the Contractor prior to the issuance of a certificate of substantial completion.
- H. Contractor to provide a written acceptance by that the turf and base system is installed in accordance with their recommendations prior to final completion.

3.11 DISPOSAL

- A. Remove waste material--including trash, and debris--and legally dispose of it off the City's property.

3.12 MANUFACTURER'S SERVICES

- A. Services of a manufacturer's representative, or manufacturer's certified or authorized installer, who is experienced in installation of the specified playground safety surface, shall be provided. The representative shall supervise or inspect the installation to ensure that the safety surfacing meets the impact attenuation requirements as specified herein.
- B. Regardless of the installer, the manufacturer's representative shall certify that the installation complies with the manufacturer's instructions and specifications.

END OF SECTION

SECTION 32 31 19
DECORATIVE METAL FENCES AND GATES

PART 1 - GENERAL

1.01 SUMMARY

- A. Section Includes: all labor, materials, equipment, tools, accessories, transportation, and services as required for Decorative Metal Fences and Gates.
- B. Related Requirements:
 - 1. Section 03 20 00, Concrete Reinforcing
 - 2. Section 32 11 00, Base Courses
 - 3. Section 32 13 00, Rigid Paving
 - 4. Section 05 50 00, Metal Fabrications

1.02 PRICE AND PAYMENT PROCEDURES

- A. Refer to City of Cupertino Project Manual.

1.03 REFERENCES

- A. AWS, Code for Arc and Gas Welding.
- B. Society for Protective Coatings, Surface Preparation Specifications, latest edition.
- C. Section 75 of the Caltrans Standard Specifications.
- D. Applicable sections of ASTM as noted.

1.04 ADMINISTRATIVE REQUIREMENTS

- A. Coordination: Coordinate all metal work with adjoining work for details of attachment, fitting, etc. Do all cutting, shearing, drilling, punching, threading, tapping, etc., required for miscellaneous metal or for attachment of adjacent work.

1.05 SUBMITTALS

- A. Submit shop drawings where required by the technical specifications or on the drawings for:
 - 1. Ornamental Metal Fence and Gates
- B. Shop drawings shall show dimensions, sizes, thicknesses, gauges, finishes, joining, attachments, and relationship of work to adjoining construction. Where concrete, masonry, or other materials must be set to exact locations to receive work, furnish assistance and direction necessary to permit other trades to properly locate their work. Where welded connectors, concrete or masonry inserts are required to receive work, shop drawing shall show exact locations required, and all such drawings shall be furnished to the trades responsible for installing the connectors or inserts. Catalog work sheets showing illustrated cuts of item to be furnished, scale details and dimensions may be submitted for standard manufactured items.

1.06 QUALITY ASSURANCE

- A. Qualifications
 - 1. Fabrication and welding shall be licensed operations.
- B. Field Measurements: Verify dimensions with work of other sections that adjoins the Decorative Metal Fencing work.
 - 1. Measurements of adjoining work shall be taken, so that the Decorative Metal Fencing work shall fit closely into the spaces provided.
 - 2. If any conflicts between design and actual on-site conditions are encountered, Shop Drawings showing the nature and location of conditions shall be submitted to the Engineer for determination, prior to fabrication of Decorative Metal Fencing.

- C. Shop Assembly: Insofar as practicable, fitting and assembly of work shall be done in shop.
 - 1. Work that cannot be permanently shop assembled, shall be completely assembled, marked, and disassembled in shop before shipment to insure proper field assembly.
 - 2. Shop fabricated items shall properly fit in the field condition. In event that shop-fabricated items do not fit the field condition, the item shall be returned to the shop for correction.

1.07 DELIVERY, STORAGE, AND HANDLING

- A. Materials: Attention is directed to Section 6, Control of Materials of the City Standard Specifications and these Special Provisions. All materials required to complete the work under this contract shall be furnished by the Contractor.
- B. Finished materials: Protect existing finishes and new Decorative Metal Fencing finishes against soiling, staining or damage from scratches and abrasion. Maintain protection during construction and until Final Occupancy.
- C. Special Handling: All tools and equipment utilized in handling, storage, and installation of the stainless steel must be of stainless steel or of a non-metallic material to prevent iron particle marking or scoring of the stainless steel finish.

1.08 WARRANTY

- A. Final Guarantee: Contractor shall provide guarantee per City of Cupertino Project Manual.

PART 2 - PRODUCTS

2.01 ORNAMENTAL METAL FENCE AND GATES

- A. Manufacturer/Model No.: Ameristar, Montage Plus 'Majestic', with two rails and 3" Play Picket Air-Space. See drawings for gate information.
- B. Manufacturer Info – Sales and Marketing Contact: Bonny Franklin, bonny.franklin@assaabloy.com, direct 916.926.1681
- C. Manufacturer Info –Orders & quote requests: ameristarregion1@assaabloy.com phone 888.333.3422 | fax 877.926.3747
- D. Color: Black

2.02 MATERIALS

- A. General: use new and clean materials as specified, having structural properties sufficient to safely sustain or withstand stresses and strains to which materials and assembled work will be subjected.
- B. Wind Load: Decorative Metal Fencing shall be designed, fabricated and installed to withstand a wind load of at least one hundred and twenty miles per hour (120 MPH) on entire assembly, and shall meet all building codes, code load requirements, seismic, and other regulatory requirements applicable to the proposed installation.

2.03 DESCRIPTION

- A. Steel Tubing: Shall conform to ASTM A500, Grade B cold formed structural tubing.
 - 1. Steel Plates, Shapes, and Bars: Conforming to ASTM A 36.
 - 2. Concrete Inserts: Malleable iron, ASTM A-47, or cast steel, ASTM A-27, inserts, with steel bolts, washers and shims; hot-dip galvanized.

3. Anchors and insert: Furnish inserts and anchoring devices to be built into other work for installation of miscellaneous metal items. Coordinate delivery to job site to avoid delay. Use non-ferrous metal or hot-dip galvanized anchors and inserts for exterior resistance. Use toothed steel or lead expansion bolt devices for drilled-in-place anchors. Furnish inserts, as required, to be set into concrete or masonry work.

B. Fasteners

1. Furnish of basic metal and alloy, matching finished color and texture as metal being fastened, unless otherwise indicated.
2. Provide fasteners with rated holding power four (4) times design working load.
3. Where exposed to view, fasteners shall be tamper resistant.
4. For Stainless Steel: Stainless steel, AISI Type 304, non magnetic.
5. Anchors and Bolts: Shall conform to ASTM 307.
6. Intent of Drawings: The drawings are intended to show the number, size and spacing of nails, bolts and screws, etc., required for structural strength. If any particular joint is not shown on the drawings, it shall be provided with bolts, screws, and/or nails, as required to be consistent with the fully detailed joints, and shall be subject to the approval of the Engineer.
7. Furnish all hardware required for fastenings, as shown on the drawings, and as specified herein, and as required to complete the work. All fasteners shall be hot-dip galvanized. Fasteners shall include, but not be limited to, the following:
8. Nails: Unless otherwise noted, nails shall be hot-dipped two ounces per square foot (2 oz/sf) common wire of adequate size for type of fastening, ASTM 153.
9. Bolts: Shall be machine bolts, lag bolts, or carriage bolts of structural grade steel conforming to ASTM A-153, of sizes indicated on the drawings. Anchor bolts shall have cut threads.
10. Washers: Shall be of standard malleable iron, ASTM 153.
11. Galvanizing
 - a. All ferrous metal fabrications shall be hot dipped galvanize per ASTM A-153. Fabrications to be painted shall be acid etched prior to painting. Galvanizing for iron and steel hardware shall be in accordance with ASTM 153.
 - b. If necessary, the threads of nuts shall be retaped after galvanizing repair compound.

2.04 WELDING MATERIALS

A. Description

1. Materials and fabrication shall be in accordance with the standards as shown in section 1.03A.
2. Welding and equipment shall conform to AWS, Code for Arc and Gas Welding.
3. ANSI D.1.1; Type required for materials being welded.

B. Performance/Design Criteria

1. Capacities Nails: Unless otherwise noted, nails shall be hot-dipped two ounces per square foot (2 oz/sf) common wire of adequate size for type of fastening, ASTM 153.
 - a. Anchors and bolts shall conform to ASTM 307.

PART 3 - EXECUTION

3.01 INSTALLATION

- A. All parts and all members of the work of this section shall be the size, shape, and profile indicated by the Contract Documents. Methods of fabrication, assembly and erection, unless otherwise specifically stated, shall be at the discretion of the Contractor.

- B. Exposed Work: In addition to requirements specified herein or shown on drawings, all surfaces exposed to view shall be clean, and free from dirt, stains, grease, scratches, distortions, waves, dents, buckles, tool marks, burrs, and other defects which mar appearance of finished work.
 - 1. Metal work exposed to view shall be straight and true to line or curve, smooth arises and angles as sharp as practicable without draft, miters formed in true alignment, profiles accurately intersecting, and with joints carefully matched to produce continuity of line and design.
 - 2. Exposed fastenings, where permitted by Engineer, shall be of the same material, color, and finish as the metal to which applied, unless otherwise indicated, and shall be of the smallest practicable size.
- C. Structural/ Loading Criteria: Install Decorative Metal Fencing to provide items with capabilities to safely sustain or withstand stresses and strains to which materials and assembled work will be subjected. Comply with project loading and structural criteria and local building code authorities.
- D. Coordinate completion of surrounding and adjacent construction to assure flush and, where applicable, waterproofed installation.

3.02 INSPECTION

- A. General: The Engineer will inspect Decorative Metal Fencing at the Contractor's facility and delivery location, and in accordance with Section 6, Control of Materials of the referenced Caltrans Standard Specifications. The Engineer will inspect Decorative Metal Fencings for damage and defects before and after installation.

3.03 METAL FABRICATIONS AND COMPONENTS

- A. Edges and Cutting: Make edges and cuts accurate, clean, sharp, square, smooth, and free of burrs. Make cuts without deforming adjacent surfaces or materials.
- B. Holes: Drill or cleanly punch holes (do not burn), so that holes will be accurate, clean, neat, and sharp without deforming adjacent surfaces.
- C. Connections: Make connections with tight joints capable of developing full strength of member, flush unless indicated otherwise, and formed to exclude water where exposed to the elements.
 - 1. For work exposed to view, use concealed threaded fasteners (unless welded or other connections indicated) with joints accurately fitted, flush, and rigidly secured with hairline contacts (unless joints other than hairline indicated).
- D. Threaded Fasteners (Bolts and Screws):
 - 1. In general, use bolts for field connections only as detailed.
 - 2. Provide washers under all heads and nuts. Use beveled washers where bearing is on sloped surfaces.
 - 3. Draw all nuts tight and nick threads of permanent connections to prevent loosening.
 - 4. Where screws must be used for permanent connections in ferrous metal, use flat head type, countersunk, with screw slots filled and finished smooth and flush.
 - 5. Make threaded connections tight with threads entirely concealed.
 - 6. Use lock nuts.
 - 7. Where exposed to view, fasteners shall be of the tamper proof type with head size as small as possible.
- E. Welding: Comply with recommendations of the AWS using electrodes and methods recommended by the manufacturer of the metals being welded.
 - 1. Welds shall be continuous, except where spot welding is specifically permitted.
 - 2. Welds exposed to view shall be ground flush and dressed smooth with and to match finish of adjoining surfaces so that the joint will not be visible.
 - 3. Undercut metal edges where welds are required are to be ground flush and dressed smooth.

4. All welds on or behind surfaces which will be exposed to view shall be executed to result in a finished surface free of imperfections such as pits, runs, splatter, cracks, warping, dimpling, depressions, or other forms of distortion or discoloration. Remove weld spatter and welding oxides from all welded surfaces.
 5. Maintain continuity of the finish at exposed surfaces and edges near the exposed joints, which shall be sharp and square, without burrs, flattening, thinning, easing of edge or other irregularities.
 6. Make all permanent connections in ferrous metal surfaces using welds where at all possible.
 7. Regalvanize all welds.
 8. Do not use bolts or screws where they can be avoided.
 9. Welds shall be made only by operators experienced in performing the type of work indicated.
 10. Where welding is done in proximity to glass or finished surfaces, such surfaces shall be protected from damage due to welds, sparks, splatter, or tramp metal.
- 3.04 SUPPLEMENTARY PARTS INCLUDING FRAMING, BRACING, SUPPORTS, AND THE LIKE
- A. Provide as necessary to complete each item of work, even though such supplementary parts are not shown or specified.
 - B. Use materials compatible with adjacent and connecting elements.
 - C. Framing, plate reinforcing, supplementary framing or reinforcing, bracket assemblies, and the like, required for the support, framing, reinforcing, bracing, etc. of Decorative Metal Fencing shall be of such sizes and shapes as indicated on the drawings and details, or as required to suit the conditions.
 - D. Provide all necessary supports and accessory items such as inserts, hangers, braces, struts, clip angles, anchors, bolts, nuts, welds, etc. as required to properly and rigidly fasten, anchor or attach work of this Section in place and to the concrete and other connecting and adjoining work.
- 3.05 FINISHES
- A. General
 1. All finishes shall be shop applied, unless otherwise approved in writing by the Engineer.
- 3.06 ATTACHMENTS
- A. Unless otherwise indicated, work to be attached to concrete shall be anchored by bolts previously placed for Decorative Metal Fencing installations into embedded metal inserts, or drilled in expansion shields.
 - B. Work attached to miscellaneous steel shall be anchored by bolts or screws to suit condition.
 1. Power-actuated fasteners are not permitted.
 - C. Provide shims, slotted holes, or other means necessary for leveling, plumbing, and other required adjustments.
 - D. Do all necessary drilling, tapping, cutting or other preparation of surrounding construction in the field accurately, neatly and as necessary for the attachment and support of the Decorative Metal Fencing. Obtain approval of the Engineer prior to such preparation to work of others where cutting or other preparation s may affect structural integrity or exposed finish.
- 3.07 PROTECTION

- A. Regardless of kind, size, type, or whether delivered by the Contractor or by a common carrier, Decorative Metal Fencing panels shall be protected by thorough wrapping, tarping, or other methods to ensure that Decorative Metal Fencing panels are not damaged by weather conditions and during transit. Decorative Metal Fencing panels shall be dry during transit and shipped on pallettes, in crates, or tier racks. Padding and protective materials shall be placed between Decorative Metal Fencing panels as appropriate. Finished Decorative Metal Fencing panels shall be transported and stored by method that protects the face of Decorative Metal Fencing panels from damage. The Contractor shall replace wet, damaged, and defective Decorative Metal Fencing panels.
- B. Decorative Metal Fencing panels shall be stored in a dry environment at all times. Decorative Metal Fencing panels shall not rest directly on the ground or become wet during storage. Decorative Metal Fencing panels shall be stored indoor if duration of the storage will exceed thirty (30) days.
- C. After completion of the work of this Section and the work of adjacent trades, or at such times as directed by the Engineer, all temporary protection shall be removed and the exposed surfaces of all work of this Section shall be cleaned and left free of smears, scratches, and abrasions, to the satisfaction of the Engineer.
 - 1. Any damages to finishes shall be repaired at no additional cost to the City.
 - 2. In the event that damage is not repairable, remove and replace such items at no additional cost to the City.

END OF SECTION

SECTION 32 80 00

IRRIGATION

PART 1 – GENERAL

1.0 SUMMARY

- A. Work shall include the following: Provide materials, labor, equipment, and services necessary for the furnishing and the installation of a complete irrigation system, which includes connections to, and repair of existing irrigation equipment system as shown on the Drawings and as specified herein. The work includes, but is not limited to:
1. Making connections to the existing 4-inch pressurized mainline, existing low voltage control wiring, electrical supplies, and to the existing irrigation system
 2. Trenching and stockpiling excavation materials and refilling trenches
 3. Providing a complete system including piping, valves, fittings, sprinkler heads, automatic controls, and final adjustment of heads to insure complete head-to-head coverage.
 4. Installing a new, wall mounted automatic smart controller.
 5. Installing low voltage control wiring to and from the irrigation controller to the proposed control valves as indicated on the Drawings.
 6. Reconnecting existing low voltage control wiring to proposed system 'A' remote control valves.
 7. Installing flow sensor, master control valve and associated low voltage sensor and control wiring.
 8. Replacement of unsatisfactory materials, including existing irrigation equipment to remain.
 9. Clean-up, inspection, and acceptance & approval for 3-month Maintenance Period.
 10. Performing Tests.
 11. Providing record drawings and submittals.
 12. Providing two (2) laminated and color-coded plans for the new as-built irrigation system, indicating valve assignments.
 13. Provide (2) each extra heads and nozzles for future maintenance.

1.1 RELATED WORK

- A. City of Cupertino Project Manual
- B. Section 31 10 00: Site Clearing
- C. Section 32 93 00: Planting

1.2 QUALITY ASSURANCE

- A. Requirements of Regulatory Agencies:
1. All work and materials shall be in conformance with the latest rules and regulations of the National Electric Code; The Uniform Plumbing Code, published by the Western Plumbing Officials Association, and the State of California Model Water Efficient Landscape Ordinance (MWELO) requirements.

1.3 SUBMITTALS

- A. Submittals per the requirements as stated in the City of Cupertino Project Manual.
- B. Material List: Submit six (3) copies of complete material list for review for compliance with the Contract Documents. Material list shall include the manufacturer, model number and description of all materials and equipment to be used. Include all sealants, cements, and other proprietary items.
- C. Detail Drawings: Submit detail drawings for all assemblies not detailed on the Drawings.
- D. Record Documents: Submit prior to the 3-month Maintenance Period.
 - 1. Show every change from the original drawings and specifications and the exact "Record Drawing" locations, sizes, and kinds of equipment.
 - 2. Dimension from two (2) permanent points of reference, building corners, sidewalk, or road intersections, etc., the location of the following items:
 - a. Connection to existing water lines.
 - 3. Delivery of the Record Documents will not relieve the Contractor of the responsibility of furnishing required information that may be omitted from the Record Documents.
- E. Operation and Maintenance Manuals: Prepare and deliver, at least ten calendar days prior to completion of construction, two hard cover, three-ring binders containing the following information:
 - 1. Two 11X17 laminated and color-coded plans of the as-built irrigation system, indicating all valve assignments at the controller.
 - 2. Index sheet stating Contractor's address and telephone number and list of equipment with name and addresses of local manufacturer's representatives.
 - 3. Catalog and parts sheets on all material and equipment installed under this Section.
 - 4. Complete operating and maintenance instructions for all major equipment.
 - 5. Complete and dated warranties for all materials used.
 - 6. Instruction of City staff in the operation of the irrigation controller, minimum of two hours.

1.4 SPECIAL TOOLS AND EQUIPMENT

- A. Special Tools and Equipment necessary to maintain and operate all irrigation equipment: Submit to the City Representative at least ten calendar days prior to final acceptance of the irrigation system.
- B. Extra heads and nozzles of each type of head used, two of each. Submit to the City Representative at least ten calendar days prior to final acceptance of the irrigation system.
- C. Extra inline emitter dripline of each type of dripline used two 500-foot rolls of each. Submit to the City Representative at least ten calendar days prior to final acceptance of the irrigation system.

1.5 PRODUCT DELIVERY, STORAGE AND HANDLING

- A. Coordinate on-site storage of materials with other trades. Protect products from weather or other conditions, which would damage or impair their effectiveness. Store products on-site in such a manner that they may be readily inspected.

- B. Exercise care in handling, loading, unloading, and storing of PVC pipe and fittings. Transport all PVC pipe in a vehicle, which allows the length of pipe to lie flat so not to subject it to undue bending or concentrated external load at any point. Discard any section of pipe that has been dented or damaged and, if installed, replace it with new piping.

1.6 JOB CONDITIONS

- A. General: Areas to receive work are to be received by the Contractor free of debris, concrete, base rock, asphalt, trash, and litter down to the existing site soil and or concrete sub slab at commencement of work, except where noted on the Drawings.
- B. Protection: Become acquainted with all site conditions. Take necessary precautions to protect site condition and improvements to remain. Damage incurred by this Contractor shall be repaired to its original condition, or equal replacement shall be provided at no additional cost to the City Representative. Repair and replacement shall be done to the satisfaction of the City Representative. Should utilities or other conditions not shown on the Drawings be found during the course of the work, report to the City Representative in writing and obtain the City Representative's instructions prior to proceeding with the work affected.
- C. Verification: Field verify all dimensions, grades, and coordinates. Report all discrepancies to the City Representative in writing, and obtain the City Representative's instructions, prior to proceeding with the work affected.

1.7 SUBSTITUTIONS

- A. General: Submit proposals for substitutions per City of Cupertino Project Manual prior to proceeding with the work of this Section.

1.8 WARRANTY

- A. All materials and workmanship shall be as specified and shall be under warranty per requirements as stated in City of Cupertino Project Manual. The warranty shall apply for a minimum period of one year from the date of Substantial Completion. During and at the end of this period, all required repairs and adjustments, including adjustment to grade, shall be made including all repairs to other work made necessary thereby, without additional expense to the City.
- B. Repair of Damage: All damage to paving, planting, structures, and other improvements due to settlement of improperly compacted trench backfill shall be promptly repaired to the satisfaction of the City Representative and without additional cost to the City. The Contractor is also responsible for damage caused by leaks in the piping systems being installed or having been installed.
- C. Present to the City Representative at the time of Substantial Completion, warranties for all materials used.
- D. The City reserves the right to make temporary repairs as necessary to keep the sprinkler system equipment in operating condition. The exercise of this right by the City Representative shall not relieve the Contractor of his responsibilities under the terms of the warranty as specified herein.

PART 2 – PRODUCTS

2.1 GENERAL

- A. Use only new materials of brands and types specified herein.

2.2 PIPE AND FITTINGS

- A. Polyvinyl Chloride (PVC) Pipe: Pipe shall be made from NSF approved, Type 1, Grade 1 PVC compound conforming to ASTM resin specification D1784. All pipes must meet requirements set forth in Federal Specification PS-22-70 with an appropriate standard dimension ratio.
- B. All PVC pipe must bear the following markings:
 - 1. Manufacturer's name
 - 2. Nominal pipe size
 - 3. Schedule of class
 - 4. Pressure rating in P.S.I.
 - 5. NSF (National Sanitation Foundation) approved
 - 6. Date of extrusion
- C. Pressure Pipe: 4" and smaller piping shall be PVC Class 315 plastic pipe.
- D. Non-pressure Lateral Line Piping: PVC Schedule 40 plastic pipe.
- E. Fittings:
 - 1. Fittings for solvent weld Class 315 PVC plastic pipe shall be Schedule 80. Fittings for Schedule 40 PVC plastic pipe shall be Schedule 40, Type 1, Grade 1, NSF approved conforming to ASTM D 2466.
 - a. All PVC fittings shall bear the manufacturer's name or trademark, material designation, size applicable I.P.S. schedule and NSF seal of approval.
- F. Solvent cement and primer for PVC solvent-weld pipe and fittings shall be to type and installation methods prescribed by the manufacturer.
- G. Sleeves: All piping which runs under pavement shall be installed in Schedule 40 PVC sleeves two sizes larger than irrigation pipe to allow for easy removal and insertion. Length of sleeve shall provide for a minimum of 1 foot overhang on each side of the pavement.
- H. Flow Sensor Communication Cable Conduit: Cable shall be enclosed in Schedule 40 PVC conduit.

2.3 BACKFLOW DEVICE

- A. Unit shall comply with City requirements.
- B. The reduced pressure zone assembly shall consist of two independently operating, spring loaded, "Y" pattern check valves and one hydraulically dependent differential relief valve. The assembly shall automatically reduce the pressure in the "zone" between the check valves to at least 5psi lower than inlet pressure. Should the differential between the

upstream and the zone of the unit drop to 2psi, the differential relief valve shall open and maintain the proper differential.

- C. Mainline valve body and caps including relief valve body and cover shall be Lead Free* cast copper silicon alloy. Check valve moving member shall be center stem guided. All hydraulic sensing passages shall be internally located within the mainline and relief valve bodies and relief valve cover. Diaphragm to seat area ratio shall be 10:1 minimum. Relief valve shall have a removable seat ring. Check valve and relief valve components shall be constructed so they may be serviced without removing the valve body from the line. All seat discs shall be reversible. Shutoff valves and test cocks shall be full ported ball valve.
- D. The assembly shall be rated to 175psi (12.1 bar) working pressure and water temperature range from 32°F to 140°F (0°C - 60°C). The Lead Free* Reduced Pressure Zone Assemblies shall comply with state codes and standards, where applicable, requiring reduced lead content.
- E. The assembly shall meet the requirements of ASSE Standard 1013; AWWA Standard Code C511; CSA Standard B64.4; and approved by the Foundation for Cross-Connection Control and Hydraulic Research at the University of Southern California.
- F. In a flow condition the check valves are open with the pressure between the checks, called the zone, being maintained at least 5.0psi lower than the inlet pressure and the relief valve is maintained closed.
- G. Should abnormal conditions arise under no flow or reversal of flow; the differential relief valve will open and discharge to maintain the zone at least 2psi lower than the supply. When normal flow resumes, the zone's differential pressure will resume, and the relief valve will close.
- H. Reduced pressure backflow prevention device shall be as specified on the drawings or approved equal.
- I. Reduced pressure backflow prevention device shall be installed with enclosure as specified on the drawings.
- J. Reduce pressure backflow prevention device shall be installed with a cage per the City of Cupertino's selection.

2.4 TRACER WIRE

- A. A No. 12. Green Type TW plastic-coated copper tracer wire shall be installed with non-metallic main lines.

2.5 IRRIGATION CONTROLLER

- A. The Contractor shall furnish and install (1) automatic smart controller as shown on the Drawings.

2.6 WIRELESS RAIN SENSOR

- A. The Contractor shall furnish and install (1) wireless rain sensor as shown on the Drawings.

2.7 CONTROL WIRES

- A. Type: Copper with UL size 14-1. Common ground wire with white insulating jacket; individual control wires with insulating jacket of color other than white.
- B. Splices: 'DBY' by 3M, Scotchlok 3570 by 3M.

2.8 MASTER CONTROL VALVE

- A. Manufacturer: Shall be Superior or approved equal.
- B. Description: Model as indicated on drawings or approved equal, brass globe valve that provides dirty and recycled water protection and has no minimum flow requirement.
- C. Valve shall be Normally Open.
- D. Material
 - 1. Master valve shall have dual chamber design and provide no minimum flow capability.
 - 2. External plumbing shall allow easy maintenance to filter assembly.
 - 3. 600 lb. test nylon reinforced EPDM diaphragm.
 - 4. Non-continuous flow through solenoid
 - 5. Connection configuration shall be threaded.
 - 6. Maximum working pressure shall be 200 psi with a minimum working pressure of 20 psi.
 - 7. Operating flow ranges from 0 to 200 GPM.
 - 8. Standard 24 VAC with in-rush current of 0.45 A and a holding current of 0.30 A.

2.9 FLOW SENSOR

- A. Description: Model as indicated on drawings or approved equal, fully compatible with the automatic controller.
- B. The flow sensor features a proprietary, non-magnetic sensing mechanism and a six-bladed design. It shall have a forward-swept impeller design to provide higher, more constant torque, and shall be less prone to fouling by water-borne debris.
- C. Material
 - 1. Water flow shall turn the flow meter impeller blades, and a low impedance 9VDC signal shall be transmitted with a frequency proportional to the flow rate. The signal shall travel up to 2,000' between the flow meter and the controller without the need for amplification. Controllers shall not require any additional interface and supply the DC signal directly to the flow meter.
 - 2. The flow sensor shall be within a Brass Tee as manufactured by flow meter manufacturer.

2.10 VALVES

- A. Remote control, isolation valves, ball valves and gate valves shall be brass material as specified in the irrigation legend or approved equal.

2.11 VALVE BOXES

- A. Provide valve boxes for master control valve, flow sensor, remote control valves, gate valves, ball valves and quick coupling valves.
- B. The housing for valves shall be manufactured from calcium carbonate and polyester resins interlaced with fiberglass and ultraviolet inhibitors including locking, vandal proof lids, and all required extensions, where and as shown on the Plans. The lids shall be cast with lock/key mechanism and shall have cast letter 1" - inch high with the word IRRIGATION. Manufacturer shall be NDS, Brooks Products, or equal.

2.12 QUICK COUPLING VALVES

- A. As indicated on the Drawings. All quick coupling valves to be 1", brass, of manufacturer and model specified in the irrigation legend, or approved equal.

2.13 ROTORS AND SPRINKLERS

- A. As indicated on the Drawings.
- B. All irrigation rotor and sprinkler heads to be installed as detailed on the drawings.

2.14 SUBSURFACE DRIP IRRIGATION EQUIPMENT

- A. As indicated on the Drawings.
- B. Dripline shall provide consistent irrigation at designated flows and emitter spacing and shall conform to an inside diameter (ID) of 0.560" (14,2 mm) and an outside diameter (OD) of 0.660" (16,8 mm). The dripline shall incorporate a check valve function that will hold back up to 6' (1,8 m) of elevation (2.6 PSI; 0,2 bar check valve).
- C. PVC Manual Flush Ball Valve:
 - 1. Manual flush shall be schedule 40 PVC ball valve.
 - 2. As indicated on the Drawings.
- D. System Operation Indicator:
 - 1. Pop-up indicator shall be 6-inch high with yellow UV-resistant plastic and 1/2" FTP inlet.
 - 2. As indicated on the Drawings.
- E. Air Vacuum Relief Valve:
 - 1. Air/ vacuum relief valve shall be an O-ring seal type with inlet threads of 1/2-inch (MIPT) capable of venting air until 4 PSI is achieved at system startup and vacuum relief when 4 PSI is reached during system shutdown.
 - 2. The air/ vacuum relief valve shall be rated at a maximum operating pressure of 100 PSI. The air/ vacuum relief valve body and shuttle shall be constructed of corrosive-proof engineering thermoplastics.
 - 3. The seal shall be a rubber O-ring
 - 4. As indicated on the Drawings.

2.15 TREE ROOT WATERING SYSTEMS

- A. The Root Zone Watering System shall be pre-assembled and constructed of a plastic mesh tube with a removable, perforated end cap. It shall have an internal baffle system to aid in dispersing the water throughout the root zone. The system shall have a locking cap to body design which attaches to the tubing. When specified with an integral bubbler, a prefabricated ½-inch male threaded swing joint shall be included on the assembly, a pressure compensating bubble and an adjustable check valve.

2.16 BACKFILL SOIL

- A. All backfill for irrigation system trenching shall be free of rocks and clods over ½-inch in diameter. Backfill shall be free from refuse, plants or roots, clods, weeds, sticks, solvents, petroleum products, concrete, base rock, or other deleterious or extraneous material. Backfill shall be free of soil-borne diseases and shall be capable of sustaining healthy plant life.

PART 3 – EXECUTION

3.1 GENERAL REQUIREMENTS

- A. The Contractor is responsible for installing a new water meter and a new irrigation system. Report to the City Representative all conditions preventing compliance with this requirement and obtain the City Representative's instructions prior to proceeding with the work affected. Failure to report to the City Representative constitutes acceptance of this requirement by the Contractor.

3.2 FIELD QUALITY CONTROL

- A. The Contractor shall be responsible for notifying the City Representative in advance for the following observation meetings, according to the time indicated:
 1. Field Layout - 48 hours.
 2. Pressure supply line installation and testing - 48 hours.
 3. Automatic controller installation - 48 hours.
 4. Control wire installation - 48 hours.
 5. Lateral line and sprinkler installation - 48 hours.
 6. Coverage test - 48 hours.
 7. Maintenance Period Observations - Seven (7) calendar days.
 8. Final Observation - Seven (7) calendar days.

3.3 SITE CONDITIONS

- A. Inspect and be familiar with all existing site utilities. Exercise extreme care in excavation and working near existing utilities. Contractor shall be responsible for damages to utilities, which are caused by his operations.
- B. Take extreme care to protect existing irrigation heads, lines, and valves to remain. Contractor shall repair at his cost to damages incurred to the existing system.

- C. Protection of In-Place Conditions
 - 1. Surrounding areas, surfaces, and appurtenances already in place shall be protected during installation of planting irrigation.
 - 2. Exercise care in excavation and working near existing utilities. Check existing utility locations. Contractor shall be responsible for damages caused during his operations to any existing underground utility lines including existing irrigation control wires, storm sewers, sanitary sewer systems, gas lines, potable water lines, irrigation lines, telephone cables, gasoline or oil lines, electrical cables, or any other systems (buried or overhead). If such damage should occur, Contractor shall immediately notify Landscape Architect, Owner, and department affected by such damages and shall pay all ensuing costs.
- D. Protection:
 - 1. Provide barricades, coverings, warning signs, lights and other protection required by local code or OSHA to prevent damage to existing improvements to remain and protect the public.
 - 2. Protect improvements on adjoining areas as well as those on the project site.
 - 3. Restore any improvements damaged by this work to original condition, as acceptable to CITY REPRESENTATIVE or other parties or authorities having jurisdiction.

3.4 COORDINATION

- A. The Contractor shall schedule and coordinate work with other trades and shall verify the connection with water supply prior to commencing work.
- B. Install pipe and sleeves under pedestrian paving and through walls and footings.
- C. Do not install piping or sprinkler head until walls, footing, curbs, and other related structures are in place.
- D. Do not install pipe until planting areas have been prepared as indicated under the Planting Plan.

3.5 LAYOUT

- A. Arrange work to obtain coordinated installation with proper clearance, running straight and direct as possible, and forming right angles and parallel lines with adjacent structures and systems.
- B. Prior to installation, stake out all pressure supply lines, and routing and location of quick coupler valves.
- C. Coordinate installation of entire irrigation system including pipe, so there shall be no interference with utilities or other construction or proposed locations of trees and shrubs.
- D. Line Clearance: Underground lines shall have a minimum horizontal clearance of 2- inches from each other, 6-inches between main line and lateral line. All lines shall have a minimum horizontal clearance of 12-inches from the lines of other trades. This requirement does not apply to any lines crossing at angles from 45 to 90 degrees.
- E. Restore surfaces, existing underground installation, etc. damaged or cut as result of excavations, to original conditions. Where irrigation lines, irrigation trenching and pipe work

interfere with other utilities, report to the City Representative in writing and obtain the City Representative's instructions prior to proceeding with the work affected.

- F. Irrigation plans are diagrammatic. Pipelines shown parallel in the Drawings may be placed in a common trench, provided that a minimum horizontal distance of three inches (3") is maintained between buried lines.
- G. Driplines are shown schematically. Suspected discrepancies in coverage or sizes of areas to be irrigated shall be brought to the attention of the Engineer prior to installation. Contractor shall re-direct work to avoid delay while awaiting resolution.

3.6 TRENCHING AND BACKFILLING

- A. Trenching: Dig trenches straight and support pipe continuously on bottom of trench. Lay pipe to an even grade. Trenching excavation shall be to the following depths:
 - 1. Provide a minimum of 24 inches cover for all pressure supply (main) lines 4" and larger. Provide a minimum of 18 inches cover for all pressure supply (main) lines 3" and smaller.
 - 2. Provide a minimum of 12 inches cover for all non-pressure (lateral) lines.
 - 3. Provide a minimum cover of 18 inches for all control wiring.
- B. Backfilling: The trenches shall not be backfilled until all required tests are performed. Trenches shall be carefully backfilled with the specified backfill. If settlement occurs and subsequent adjustments in pipe, valves, emitters, bubblers, lawn or planting, or other construction are necessary, the Contractor shall make all required adjustments without cost to the City.
 - 1. In planting areas: Backfill shall be manually or mechanically compacted to a dry density of 85 percent. Backfill shall conform to adjacent grades without dips, sunken areas, humps, or other surface irregularities.
 - 2. Under Paving: All pipes located under paving shall be sleeved. Trenches located under areas where paving will be installed shall be backfilled with specified backfill (a layer 6-inches below the pipe and 3-inches above the pipe) and compacted to 95 percent compaction, using manual or mechanical tamping devices. All backfilled trenches shall be left flush with the adjoining grade. Set in place, cap and pressure test all piping under paving prior to the paving work.

3.7 HIGH VOLTAGE WIRING FOR AUTOMATIC CONTROLLERS

- A. 120-volt power connection to the automatic controller from electrical source connection shown on electrical drawings shall be provided by Contractor.
- B. All electrical work shall conform to local codes and ordinances and shall be in accordance with the National Electrical Code, most recent edition.

3.8 INSTALLATION OF PIPING

- A. Install lines (and various assemblies) in accordance with the manufacturer's instructions.
- B. Do not install multiple assemblies in plastic lines. Provide each solenoid valve and quick coupler valve with its own outlet off the main line.

- C. Install all assemblies specified in accordance with details shown on the Drawings.
- D. Coordinate work to minimize amount of sleeving required under existing pavement. Piping under existing pavement may be installed by jacking or boring. The Contractor shall obtain the City Representative's approval for all cutting or breaking of pavement prior to starting the work. Repair to the original condition at no additional cost to the City.

3.9 DRIPLINE IRRIGATION

- A. Contractor shall layout dripline, etc. for approval from CITY REPRESENTATIVE.
- B. Layout drip systems and make minor adjustments required due to differences between site and drawings. Where piping is shown on drawings under paved areas, but running parallel and adjacent to planted areas, install the piping in the planted areas.
- C. Check headers (manifolds) and dripline laterals for leaks before covering with soil.
- D. Check pressure at the site and be sure to operate below the maximum rated pressure of 58 PSI. Check and record pressure at the supply header and flush header. Any changes in pressure can be used in future troubleshooting.
- E. Be sure there is uniform soil compaction all over the site after installation.
- F. After installation, open the flush valves (one at a time) and collect some of the water to check to be sure that the installation is clean.
- G. Allow for expansion and contraction of tubing.
- H. Tie-Down Stake
 1. Stagger stakes every 3 feet in sand, 4 feet in loam, and 5 feet in clay.
 2. At fittings where there is a change of direction such as tees or elbows, use tie-down stakes close to the fitting on each leg of the change of direction.
 3. Insertion plow and trenched installations do not require tie down stakes.
- I. Air/Vacuum Relief Valves
 1. Locating at the highest point(s) of the dripline zone.
 2. Install the valve in an exhaust header or a line that runs perpendicular to the lateral rows to ensure all rows of the dripline can take advantage of the air/vacuum relief valve.
- J. Manual Line Flush Point
 1. Install the manual flush at a low point in the exhaust header of a grid layout, or at the mid-point of a Loop Layout.
 2. Install a flush port with a threaded plug or a manual flushing valve in a valve box with a gravel sump adequate to drain approximately one gallon of water.
 3. Manual flush points are normally installed as far away from the water source as possible.
- K. Dripline Flushing
 1. After all dripline feeder lines and risers are in place and connected, all necessary diversion work has been completed, and prior to the installation of any dripline, the

control valves shall be opened, and a full head of water used to flush out the lines and fittings.

2. Surface dripline shall be installed after flushing the system has been completed. Avoid contaminating dripline with debris.
3. Surface dripline shall be flushed prior to the installation of all flush valves.
4. Flush the system every two weeks for the first 6 weeks and check the water that is flushed out for cleanliness.
5. Establish a regular flush schedule for the future after these initial checks.
6. Flush the system well after any repairs are made.
7. Check the pressure at the supply and flush headers on a regular basis and compare with the pressure readings taken right after installation.

L. Winterization

1. Winterizing an irrigation system involves removing enough water to ensure that components are not damaged due to freezing weather.
2. Check the manufacturer's instructions for winterizing the valves, filters, and backflow prevention devices.
3. If compressed air is used to blowout the lines:
 - a. Compressed air may be used only be used with the flush valve open and with the air pressure at 40 psi or less.
 - b. Drip fittings are rated to 50 psi, so the air pressure must be adjusted below this pressure.
 - c. It is air volume, not pressure, which is effective when blowing out the lines.
 - d. The pressure-regulating valve that is part of the control zone regulates water, not air pressure.
 - e. With all drain ports open, compressed air should be applied until no water is seen exiting the ports.
 - f. After turning off the air, close all drain ports.

3.10 SYSTEM INSTALLATION

A. Solenoid Valves:

1. Allow at least 12 inches between valve boxes and allow 12-inches clearance between valve boxes and walk or curb. See Drawings.
2. Install each solenoid valve in a separate valve box. No soil is permitted in valve box or around valve.

B. Flushing of System:

1. After all new sprinkler risers are in place and connected, all necessary diversion work has been completed, and prior to installation of sprinkler heads, the solenoid valves shall be opened, and full head of water used to flush out the system.
2. Lines shall be free of dirt, debris and all other deleterious material that could clog the system. Sprinklers shall be installed only after flushing of the system has been accomplished.

C. Rotors and Sprinkler Heads:

1. Install the sprinkler heads as designated on the Drawings.

3.11 TESTING PIPES

- A. Pipe shall be center loaded with sufficient backfill in accordance with the paragraph on backfilling to anchor pipe before testing. No fittings shall be covered.

- B. Prior to testing, install solenoid valves; and bleed air out of all lines at line pressure. Provide vertical pipe at all high points during installation to aid in bleeding air.
- C. Notify the City Representative at least 48 hours in advance of testing. Tests shall be conducted under the observation of the Recreation & Parks Dept's Park Services Area Manager and/or Park Services Supervisor. City Representative shall give final approval, after the testing is completed.
- D. Perform testing and furnish all equipment for testing as work of this section.
- E. Apply the following test after solvent weld plastic pipe joints have cured at least 24 hours.
 - 1. Test live (constant pressure) and PCV lines hydrostatically at 125 psi minimum; maintain test pressure for six (6) hours. Contractor shall make tests and repairs as necessary until test conditions are met.
 - 2. Test lateral lines with water at line pressure; inspect visually for leaks. Retest after correcting defects.

3.12 SYSTEM ADJUSTMENT

- A. Flush and adjust all sprinkler heads for optimum performance. Adjust sprinkler heads to prevent over spray onto walks, roadways, and buildings.
- B. Upon completion of each phase of work, the entire system shall be tested and adjusted to meet site requirements and the Specifications.

3.13 SYSTEM TESTING

- A. Request the presence of the City Representative in writing at least 48 hours in advance of testing.
- B. When the irrigation system is completed, perform a test in the presence of the City Representative, including Recreation & Parks Dept's Park Services Area Manager and/or Park Services Supervisor, to determine if the water supplied to planting area is complete and adequate. The Contractor shall correct any inadequacies of coverage.

3.14 TEMPORARY REPAIRS

- A. The City reserves the right to make temporary repairs as necessary to keep the irrigation system in operating condition. The exercise of this right shall not relieve the Contractor of his responsibilities under the terms of the guarantee as specified herein. Existing landscape areas and irrigation system retained are the responsibility of the Contractor through Completion.

3.15 MAINTENANCE

- A. General: Maintain automatic irrigation system in its entirety in an acceptable working order from time of initial installation through the 60-day Maintenance Period or until Final Acceptance, whichever is longer.

- B. Maintenance Procedures: Maintenance of irrigation system consists of but is not limited to: Furnishing and replacement of broken, lost, or stolen irrigation materials, including existing to remain; flushing of irrigation system; adjustment of sprinkler heads to provide optimum amounts of water.

3.16 CERTIFIED WATER AUDIT

- A. Coordinate and provide a Landscape Irrigation Audit, to be performed by an independent Certified Landscape Irrigation Auditor, certified and in good standing with the Irrigation Association (IA), for all overhead-irrigated landscape areas. Arrange and pay for the services of the Auditor under contract work. The Auditor shall be independent of the property Owner and of all contractors associated with the property. Conduct the audit in accordance with the current edition of the IA's Landscape Irrigation Auditor's Handbook. Provide the results of the audit to the CITY REPRESENTATIVE in a report format acceptable to the Landscape Architect, with the report signed by the Auditor. Provide copies of the report to the Landscape Architect and Contractor. Include the following information in the report: Controller identification letter designation and location, station sequence numbers and valve locations, sprinkler head location description and sprinkler spacing, water pressure reading at each valve or lateral, catch device readings and locations, calculated distribution uniformity for each valve, calculated precipitation rates for each valve, and a 12-month irrigation schedule (run times per cycle, cycles per day, and days per week for each valve).
- B. Compliance with this provision is required before the Owner will issue a Letter of Final Acceptance.

END OF SECTION

SECTION 32 93 00

PLANTING

PART 1 – GENERAL

1.0 SUMMARY

A. Section Includes:

1. Plant Material
2. Planting Soils
3. Soils Testing
4. Soil Amendments and/or compost
5. Organic Fertilizers
6. Sheet Mulch (cardboard with arbor mulch)
7. Integrated Pest Management
8. Tree Staking
9. Landscape Edging
10. Protective Covering for Soil Compaction
11. Replacement of all unsatisfactory plant materials
12. Cleanup, preliminary inspection and approval
13. Protection, maintenance and warranty

B. Related Documents and Sections:

1. City of Cupertino Project Manual
2. Section 32 80 00, Irrigation

1.1 APPLICABLE PUBLICATIONS: The publications listed below form a part of this specification to the extent referenced. The publications are referred to in the text by the basic designation only.

1. American Standard for Nursery Stock ANSI Z60.1
2. American Standards for Tree Care Operations ANSI A300
3. Rescape California (previously “Bay-friendly”) Landscape Guidelines, <https://www.rescapeca.org/>
4. Building Soil Manual: Guidelines and Resources for Implementing Soil Quality and Depth BMP T5.13, Washington State Department of Ecology, www.buildingsoil.org
5. Landscaping Guide: Resource Efficient Natural Landscaping, Seattle Public Utilities, www.buildingsoil.org
6. OMRI Products List (Organic Materials Review Institute – www.OMRI.org)
7. Standard Specifications for Topsoil ASTM D 5268
8. TMECC (Test Methods for the Examination of Composting and Compost), from USCC (US Composting Council)

1.2 DEFINITIONS

- A. Backfill: The earth used to replace or the act of replacing earth in an excavation.
- B. Rescape California (previously “Bay-Friendly”): A sustainable approach to landscape management that works in harmony with the natural conditions of the watershed. Rescape California (previously “Bay-Friendly”) is a ‘Natural Landscaping’ approach that fosters soil

health and conserves water and other valuable resources while reducing waste and preventing pollution.

- C. California Department of Food and Agriculture's (CDFA) Organic Input Material (OIM) Program registers fertilizing materials to be used in organic crop and food production. The program is mandated by the Legislature and supported by the industry. Products claiming to be appropriate for use in organic production are verified to comply with the California Fertilizing Materials Law and Regulations and USDA National Organic Program Standards. OIM's are listed on the Fertilizer Product Database at www.cdfa.ca.gov/is/ffldrs/fertilizer_OIM.html.
- D. Compost is the product of controlled biological decomposition of organic materials, often including urban plant debris and food scraps. It is an organic matter resource that has the unique ability to improve the chemical, physical and biological characteristics of soils or growing media. It contains plant nutrients but is typically not characterized as a fertilizer.
 - 1. Quality compost is mature, well decomposed, stable, and weed-free, derived from agricultural and/or, food scraps and/or plant trimmings, contains no substances toxic to plants, possesses no significant objectionable odors (such as ammonia or garbage) and meets stability/ maturity indicators. It does not resemble the feedstock (the original materials from which it was derived).
 - 2. Local compost and mulch are generated from feedstock/materials sourced within 100 miles or produced at a permitted facility within 100 miles of the project site.
 - 3. Recycled compost is generated from plant trimmings and/or food scraps.
- E. Container-Grown Stock: Healthy, vigorous, well-rooted plants grown in a container, with a well-established root system reaching sides of container and maintaining a firm ball when removed from container. Container shall be rigid enough to hold ball shape and protect root mass during shipping and be sized according to ANSI Z60.1 for type and size of plant required.
- F. Crown: Also called "trunk flare" or "root flare": base of the plant's stem or trunk where the stem or trunk broadens to form roots; the area of transition between the root system and the stem or trunk.
- G. Duff Layer: The surface layer of native topsoil that is composed of mostly decayed leaves, twigs, and detritus.
- H. Finish Grade: Elevation of finished surface of planting soil.
- I. FSC-certified wood is harvested from sustainably managed forests and certified in accordance with the Forest Stewardship Council's criteria.
- J. Grasscycling means leaving the clippings on turf after mowing, so they decompose and release their nutrients in the soil.
- K. Green waste consists of the plant debris from trees, shrubs, groundcover, and turf that is generated during landscape demolition, installation, or maintenance.
- L. Hardscape includes pavements, gravels, stone and other surfacing materials used for sidewalks, patios, walkways, driveways, parking lots and other non-roof, non-landscape surfaces.
- M. Invasive plant species means species of plants not historically found in California that spread outside cultivated areas and can damage environmental or economic resources.

Invasive species may be regulated by county agricultural agencies as noxious species. (Source: California Model Water Efficient Landscape Ordinance.)

- N. Integrated Pest Management (IPM), a holistic approach to mitigating insects, plant diseases, weeds, and other pests. It involves the use of many strategies for managing, but not eliminating pests. IPM uses cultural, mechanical, physical, and biological control methods before using pesticides to control pests and diseases in the landscape. Chemical controls are applied only when monitoring indicates that preventative and non-chemical methods are not keeping pests below acceptable levels. When pesticides are required, the least toxic and the least persistent pesticide that will provide adequate pest control is applied.
- O. Mulch: Any material spread evenly over the surface of the soil to enhance the growth of plants and the appearance of the landscape.
 - 1. Recycled mulch is made from organic materials, including tree trimmings, clean (unpainted and untreated) wood, or wood and plant trimmings chipped on site. It does not include forest industry products and byproducts (such as redwood bark whole or shredded, other bark mulches, or peat moss), recycled tires or other inorganic materials.
- P. Natural Landscaping: A sustainable approach to landscape management that works in harmony with the natural conditions of the watershed. Natural Landscaping practices foster soil health, conserve water and other valuable resources while reducing waste and preventing pollution.
- Q. Organic Materials Research Institute (OMRI) is a national nonprofit organization that reviews products to determine their suitability for producing, processing and handling organic food and fiber under the USDA National Organic Program Rule
- R. Sheet mulching uses a layering system of cardboard, compost, and mulch to enhance weed suppression, or smother existing lawn for conversion to planting areas, and provide soil building benefits.
- S. Stem Girdling Roots: Roots that encircle the stems (trunks) of trees below the soil surface.
- T. Subgrade: Surface or elevation of subsoil remaining after excavation is complete, or the top surface of a fill or backfill before planting soil is placed.
- U. Subsoil: All soil beneath the topsoil layer of the soil profile and typified by the lack of organic matter and soil organisms.
- V. Subsoiling: To alleviate severe soil compaction, the use of a chisel plow subsoil ripping tool mounted on a machine of sufficient power to make vertical trenches 18 inches deep into the subsoil, 24" apart. Subsoiling fractures compacted soil without adversely disturbing topsoil, plants, and surface residue, and allows roots to grow beyond the compacted layer.
- W. Surface Soil: Soil that is present at the top layer of the existing soil profile at the Project site. In undisturbed areas, the surface soil is typically topsoil; but in disturbed areas such as urban environments, the surface soil can be subsoil.
- X. Topsoil: Soil material used as a medium for establishing and sustaining healthy plant growth. Topsoil is obtained from the soil horizons normally designated as "A" or "B" as defined by the Soil Science Society of America.

- Y. TMECC: Test Methods for the Examination of Composting and compost, published by the USDA and US Composting Council.
- Z. US Composting Council Seal of Testing Assurance (STA) Program is a compost testing, labeling and information disclosure program designed to provide the information necessary to get the maximum benefit from the use of compost. The testing program includes a suite of physical, chemical and biological tests intended to help both compost producer and purchaser to determine if the compost they are considering is suitable for the use that they are planning, and to help them compare various compost products using a testing program that can be performed by a group of independent, certified labs across the country and in Canada. (Adapted from U.S. Composting Council, www.compostingcouncil.org)

1.3 SUBMITTALS

- A. Product Data: Contractor shall provide product data for each of the following:
 - 1. A complete plant list indicating species, variety, quantity and size shall be submitted to and accepted by the Owner's Representative prior to locating plant material on-site. Include quantities, sizes (caliper, head, and container), quality, and sources for plant materials. Notify Owner's Representative of planting materials sources seven days in advance of delivery to site.
 - 2. Plant Photographs: Include color photographs in digital format of all trees that will be furnished to the Project. Take photographs from an angle depicting true size and condition of the typical plant to be furnished. Include a scale rod or other measuring device in each photograph. Identify each photograph with the full scientific name of the plant, plant size, and name of the growing nursery.
 - 3. Organic Soil Amendment products: OMRI listed soil amendments only. Submit Manufacturer's certificate.
 - 4. For any manufactured products include Manufacturer's certified analysis of standard products.
- B. Materials installed or furnished without prior acceptance by the Owners Representative may be rejected and if so, will be removed from the site by the Contractor.
- C. Samples for Verification: For each of the following:
 - 1. The following items shall be submitted in a 1-pint minimum volume of each in sealed plastic bag or container. Submittal shall be labeled with weight and source of each item. Each submittal shall represent a true sample of material to be provided at the project site
 - a. Organic Amendments
 - b. Imported Planting Soils
 - c. Mulch
 - d. Organic Compost
 - 2. Tree Staking materials: for verification of material
 - 3. Landscape Edging and Accessories: Manufacturer's standard size, to verify color and material selected.
 - 4. Sheet Mulch Materials: Sample of 100% Recycled B Flute Cardboard, roll width by 12"

- D. Lab Analysis Reports. See section 2.2 Soil Analysis Report and Recommendations for testing requirements. Submit lab reports for each of the following:
1. Soil analysis report and recommendations for on-site soil
 2. Compost technical data sheet including compost laboratory report, including test data summary page. If results are outside of acceptable parameters contractor is responsible for retesting compost or finding an acceptable alternative.
 3. Imported planting topsoil report and recommendations.
- E. Tags/Receipts. Contractor is to submit the following tags/ receipts to the landscape architect at the completion of construction prior to project acceptance.
1. Receipts for compost showing the correct volume meeting the practice description (C.9).
 2. Receipts for mulch showing product is local and recycled (D.5.2).

1.2 QUALITY ASSURANCE

- A. Preferred Qualifications:
1. Contractor shall have assigned to the project at least one employee who is a Rescape California Qualified Landscape Professional.
 2. Contractor shall have assigned to the project at least one employee who is a Certified Irrigation Contractor (Irrigation Association).
 3. It is preferred that the Contractor have assigned to the project at least one employee who is a Certified Arborist or Certified Tree Worker (International Society of Arboriculture)
 4. It is preferred that the Contractor have assigned to the project at least one employee who has experience or training in Integrated Pest Management (IPM) techniques.
- B. Required Qualifications
1. Contractor must have a valid California C-27 Contractor's license authorized by the State of California.
 2. Contractor shall provide evidence of sufficient experience with similar projects. Provide list including a minimum of five recently installed projects with location, date completed, owner, and contact person and phone number.
 3. Contractor must have assigned to the project at least one employee possessing a California State Chemical Applicator's License for the control of weeds, plant diseases and other pests.
 4. Installer's Field Supervision: Require Installer to maintain an experienced full-time supervisor on Project site when work is in progress. Supervisor shall be a Rescape California Qualified Landscape Professional, or equivalent, such as Green Gardener or G3 Certified Professional.
- C. Plant Material: Provide plants as specified in the documents including size, genus, species and variety. Any request for substitution must be reviewed and approved by the Owner's Representative. To prevent contamination by the new root-rotting plant pathogens of the Phytophthora species, source all plants from nurseries that commit to using the latest Restoration Nursery Guidelines from CalPhytos, which can be found here:
<http://www.suddenoakdeath.org/wpcontent/uploads/2016/04/Restoration.Nsy.Guidelines.final.092216.pdf>
<http://www.suddenoakdeath.org/welcome-to-calphytos-org-phytophthoras-innate-habitats/>
1. Nursery: Companies specializing in growing and cultivating, harvesting and transporting trees and plants with five years minimum documented experience comparable to:

- a. Valley Crest Tree Company: Sunol, CA 925-862-2485
 - b. Pacific Nursery: Colma, CA 650-755-2330
 - c. Boething Treeland, Portola Valley, CA 650-851-4770
2. For Native Plant Material: shall be obtained from an approved native plant nursery providing plant material grown specifically for Bay Area plant restoration projects: For nurseries other than those listed in this section as approved sources, submit nursery qualifications and experience for review and approval by City Representative and Landscape Architect.
- a. Mostly Natives Nursery, Point Reyes Station, CA, (415) 663-8835
 - b. Rana Creek Nursery, Carmel Valley, CA, (831) 659-2830
 - c. Pacific Coast Seed, Inc., Livermore, CA (925) 373-4417.
 - d. S&S Seeds, Carpenteria, CA (805) 684-0436.
 - e. Yerba Buena Nursery, Half Moon Bay, CA (650) 851-1668
- D. Testing Agencies: soil testing must be done by an accredited soils laboratory approved by the Owner's Representative. Laboratories that participate in the North American Proficiency Testing Program (NAPT) are recommended. See <http://www.naptprogram.org/about/participants> for participating laboratories
- E. Plant Material Observation: Owner's Representative shall be given the opportunity to observe plant material at site before planting to check for compliance with requirements for genus, species, variety, cultivar, size, and quality. Owner's Representative shall observe trees and shrubs further for size and condition of balls and root systems, pests, disease symptoms, injuries, and latent defects and to reject unsatisfactory or defective material at any time during progress of work. Remove rejected trees or shrubs immediately from Project site.

1.3 SUPPLIES AND EQUIPMENT

- A. Fuel conservation and low emission equipment. The Contractor will implement strategies in work operations to reduce fossil fuel consumption and emissions, such as:
- 1. Use hand-powered equipment when feasible.
 - 2. Minimize use of gas-powered blowers, especially on planting beds.
 - 3. Select smallest, most fuel-efficient equipment to accomplish task.
 - 4. Consider vehicles that operate on natural gas or biodiesel.
 - 5. Maintain all equipment properly and keep them well tuned.
 - 6. Emphasize employee carpooling to Project Site.
- B. Use local products and suppliers. The Contractor shall source materials as specified and is encouraged to suggest substitutions in favor of local materials where appropriate to be approved by Owner's Representative. The Contractor shall use local products and suppliers for all other landscape items to the extent possible to minimize fuel consumption and emissions.
- C. The Contractor shall use environmentally preferable products as specified and is encouraged to suggest substitutions in favor of recycled content or salvaged materials where appropriate to be approved by Owner's Representative.
- D. Equipment refueling and repair. The Contractor shall refuel and repair equipment in a safe manner to protect against accidental spills. Limit refueling to specific areas on a site.

Measures shall be taken to prevent, control, and clean-up spills. Clean-ups should be immediate, automatic and routine and performed by a trained staff member or a licensed cleaning company.

1.4 DELIVERY, STORAGE, AND HANDLING

- A. Packaged Materials: Deliver packaged materials in original, unopened containers showing weight, certified analysis, name and address of manufacturer, and indication of conformance with state and federal laws if applicable.
- B. Bulk Materials:
 - 1. Do not dump or store bulk materials near structures, utilities, walkways and pavements, or on existing turf areas or plants or under tree canopies.
 - 2. Provide erosion-control measures to prevent erosion or displacement of bulk materials, discharge of soil-bearing water runoff, and airborne dust reaching adjacent properties, water conveyance systems, or walkways.
 - 3. Accompany each delivery of bulk organic soil amendments with appropriate certificates.
- C. Soil and compost
 - 1. Suitable topsoil that is to be removed during construction shall be stockpiled for reuse on site. Stockpile location shall be approved by Landscape Architect.
 - 2. Compost shall be delivered to site at least 2 weeks prior to commencement of work, and sample submitted to Landscape Architect.
 - 3. Compost that is hot to the touch shall be rejected as unfinished.
 - 4. Soil and compost that is to be stockpiled for longer than two weeks shall not be placed in mounds higher than 6 feet.
 - 5. Soil and compost that is stockpiled shall be covered at least two weeks prior to installation to prevent excess moisture from saturating the soil stockpile. Check moisture content at least two days prior to soil installation.
 - 6. Soil materials shall not be handled or hauled, placed, or compacted when it is wet, as during or after rain, nor when frozen.
- D. Do not prune trees and shrubs before delivery. Protect bark, branches, and root systems from sun scald, drying, wind burn, sweating, whipping, and other handling and tying damage. Do not bend or bind-tie trees or shrubs in such a manner as to destroy their natural shape. Provide protective covering of plants during shipping and delivery. Do not drop plants during delivery and handling.
- E. Handle planting stock by root ball.
- F. Deliver plants to site after preparations for planting have been completed and install immediately after approval. If planting is delayed more than six hours after delivery, set plants and trees in their appropriate aspect (sun, filtered sun, or shade), protect from weather and mechanical damage, and keep roots moist.
 - 1. Do not remove container-grown stock from containers before time of planting.
 - 2. Water root systems of plants stored on-site deeply and thoroughly with a fine-mist spray. Water as often as necessary to maintain root systems in a moist, but not overly wet condition.

1.5 PROJECT CONDITIONS

- A. Notify Owner's Representative at least 5 working days prior to installation of plants.
- B. Protect existing utilities, paving, irrigation and other facilities from damage caused by landscape operations. Contractor shall contact the local utility companies for verification of the location of all underground utilities and shall be responsible for all damage resulting from neglect or failure to comply with this requirement.
- C. Field Measurements: Verify actual grade elevations, service and utility locations, irrigation system components, and dimensions of plantings and construction contiguous with new plantings by field measurements before proceeding with planting work.
- D. Interruption of Existing Services or Utilities: Do not interrupt services or utilities to facilities occupied by the owner unless permitted under the following conditions and then only after arranging to provide temporary services or utilities according to requirements indicated:
 - 1. Notify owner no fewer than five business days in advance of proposed interruption of each service or utility.
 - 2. Do not proceed with interruption of services or utilities without owner's written permission.
- E. Planting Restrictions: Plant during the following periods. Coordinate planting periods with maintenance periods to provide required maintenance from date of Substantial Completion.
 - 1. Fall Planting: End of September to Beginning of December
 - 2. Spring Planting: Beginning of February to End of April
- F. Weather Limitations: Proceed with planting only when existing and forecasted weather conditions permit planting to be performed when beneficial and optimum results may be obtained. Planting shall not be done while soils are wet, as after or during rain. Planting shall not be done when temperature is above 90 degrees Fahrenheit. Apply soil amendments during favorable weather conditions according to manufacturer's written instructions and warranty requirements.

1.6 WARRANTY

- A. Warranty: Installer agrees to repair or replace plantings and accessories that fail in materials, workmanship, or growth within specified warranty period.
 - 1. Failures include, but are not limited to, the following:
 - a. Death and unsatisfactory growth, except for defects resulting from abuse, lack of adequate maintenance, or neglect by owner, or incidents that are beyond Contractor's control.
 - b. Structural failures including plantings falling or blowing over.
 - c. Faulty performance of tree stabilization.
 - d. Deterioration of metals, metal finishes, and other materials beyond normal weathering.
 - 2. Warranty Periods from Date of Planting Completion:
 - a. Trees: 12 months
 - b. Shrubs, Ornamental Grasses Groundcovers and Other Plants: 3 months.
 - 3. Include the following remedial actions as a minimum:
 - a. Immediately remove dead plants and replace unless required to plant in the succeeding planting season.
 - b. Replace plants that are more than 25 percent dead or in an unhealthy condition at end of warranty period.

- c. A limit of one replacement of each plant will be required except for losses or replacements due to failure to comply with requirements.
- B. Provide extended warranty for period equal to original warranty period, for replaced plant material.
- C. Maintenance Service
 1. Initial Maintenance Service for all Trees, Shrubs and Perennials: Provide maintenance by skilled employees of Landscape Installer. Maintain in accordance with City of Cupertino standards and guidelines. Begin maintenance immediately after plants are installed and continue until plantings are acceptably healthy and well-established but for not less than maintenance period below.
 2. Maintenance Period: **3** months from substantial completion of project.

PART 2 – PRODUCTS

2.1 PLANT MATERIAL

- A. The plants listed on the plans have been selected to avoid invasive species and for low water use, diversity of species, and appropriate spacing to reach mature size without shearing. Plants have also been carefully grouped into hydrozones. No substitutions will be allowed without prior written approval of the Owner's Representative.
- B. All plant material must be neonicotinoid free
- C. Furnish nursery-grown plants true to genus, species, variety, cultivar, stem form, shearing, and other features indicated in Plant Schedule or Plant Legend shown on Drawings and complying with ANSI Z60.1; and with healthy root systems developed by transplanting or root pruning. Provide well-shaped, fully branched, healthy, vigorous stock, densely foliated when in leaf and free of disease, pests, eggs, larvae, and defects such as knots, sun scald, injuries, abrasions, and disfigurement.
- D. Trees with damaged, crooked, or multiple leaders; tight vertical branches where bark is squeezed between two branches or between branch and trunk ("included bark"); crossing trunks; cut-off limbs more than 3/4 inch in diameter; or with stem girdling roots will be rejected.
- E. Tree caliper measurements shall be taken on the trunk 6 inches above the natural ground line for trees up to and including 4 in. in caliper, and 12 inches above the natural ground line for trees over 4 in. in caliper. Height and spread dimensions specified refer to the main body of the plant and not from branch tip to branch tip.
- F. Collected Stock: Do not use plants harvested from the wild, from native stands, from an established landscape planting, or not grown in a nursery unless otherwise indicated.
- G. Provide plants of sizes, grades, and ball or container sizes complying with ANSI Z60.1 for types and form of plants required. Plants of a larger size may be used if acceptable to Owner's Representative, with a proportionate increase in size of roots or balls.

- H. Root-Ball Depth: Furnish trees and shrubs with root balls measured from top of root ball, which shall begin at root flare according to ANSI Z60.1. Root flare shall be visible before planting.
 - I. Labeling: Label at least one plant of each variety, size, and caliper with a securely attached, waterproof tag bearing legible designation of common name and full scientific name, including genus and species. Include nomenclature for hybrid, variety, or cultivar, if applicable for the plant as shown on Drawings.
 - J. If formal arrangements or consecutive order of plants is shown on Drawings, select stock for uniform height and spread, and number the labels to assure symmetry in planting.
 - K. Substitutions of plant materials will not be permitted unless authorized in writing by the landscape architect. If proof is submitted in writing that a plant specified is not obtainable, consideration will be given to the nearest available size or similar variety, with a corresponding adjustment of the contract price.
- 2.2 BIORETENTION SOIL: See Civil Drawings
- 2.3 SOIL ANALYSIS REPORT AND RECOMMENDATIONS (ALL NON-BIORETENTION AREAS):
- A. Contractor shall arrange and pay for soil testing by an accredited soils laboratory approved by the Owner's Representative. Laboratories that participate in the North American Proficiency Testing Program (NAPT) are recommended. See <http://www.naptprogram.org/about/participants> for participating laboratories
 - B. Soil submitted for testing should be a composite of samples taken from several locations in a site.
 - 1. Take samples from 10-12 spots in each area. Imagine a line dividing the area in half lengthwise, and then divide each half into five near equal sized widths. Take samples near the middle of each subsection.
 - 2. At each sampling spot dig a spade's width hole a least 8 inches deep, then shave a 1-inch slice from the side of the hole to use in the composite sample.
 - 3. Thoroughly mix the 10-12 samples from each turf or planting area together in a clean plastic bucket or bowl. Place 2 cups of the mix in a sealable plastic bag for testing (some tests may require more soil, confirm with laboratories.)
 - 4. Label the bag with site information area of sample plus name of person who took the sample and contact information.
 - B. Contractor shall request that the laboratory make soil amendment recommendations based on an 'Organic' approach to soil and landscape management, including the use of green waste compost.
 - C. At a minimum the soil analysis shall include:
 - 1. soil texture (% sand-silt-clay)
 - 2. infiltration rate (based on laboratory testing or soil texture infiltration rate table)
 - 3. pH
 - 4. total soluble salts/salinity/electrical conductivity (EC), units: dS/m or mmho/cm
 - 5. essential nutrients
 - 6. heavy metals
 - 7. percent organic matter content

8. Recommendations for amending the soil with compost to bring organic matter content to 6% and organic fertilizers to recommended levels for planting area and planting type.
- D. Submit soil lab report and any proposed soil amendments and cost adjustments to Owner's Representative for written approval. After review and written approval by the Owner's Representative, amend the soils according to said laboratory's recommendations.

2.4 SOIL AMENDMENTS

- A. Compost used in this project must:
1. Be mature, well decomposed, stable and weed free.
 2. Be derived from agricultural and/or food scraps and/or plant trimmings.
 3. Contain no substances toxic to plants.
 4. Acceptable color: dark brown to black.
 5. Acceptable odors: Soil-like, forest-like, moldy.
 6. Unacceptable odors: ammonia, rot, garbage, sourness.
 7. Not resemble the feedstock (original materials form which it was derived).
 8. Be listed by CDFA as an Organic Input Material (OIM) and/or be approved by OMRI.
 9. Be produced by a participant of the US Composting Council's STA Program.
 10. Be generated from feedstock/materials sourced within 100 miles or produced at a facility within 100 miles of the project site.

The compost laboratory report must confirm the following compost parameters: Property	Test Method	Unit of Measurement	Requirement
pH	TMECC 04.11-A Elastomeric pH 1:5 slurry method pH	units	6–8.5
Soluble salts	TMECC 04.10-A Electrical conductivity 1:5 slurry method	dS/m (mmhos/cm)	0– 5 or 10
Moisture content	TMECC 03.09-A Total solids & moisture at 70 ± 5 °C	% wet weight basis	30–60 or 35-55
Organic matter Content	TMECC 05.07-A Loss-on-ignition organic matter method (LOI)	% dry weight basis	30–60
Maturity	TMECC 05.05-A Germination and vigor	% relative to positive control	Seed emergence 80 or above Seedling vigor 80 or above
Stability	TMECC 05.08-B Carbon dioxide evolution rate	mg CO ₂ -C/g OM per day	4 or below
Pathogen	TMECC 07.01-B Salmonella < 3 MPN per 4 grams, dry weight basis	Pass/ Fail	Pass
Pathogen	TMECC 07.01-B Fecal coliform bacteria < 1,000 MPN per gram, dry weight basis	Pass/ Fail	Pass
Physical contaminants	TMECC 02.02-C Man-made inert removal and classification: Plastic, glass, and metal % > 4 mm fraction	% dry weight basis	combined total: < 0.5%
Physical contaminants	TMECC 02.02-C Man-made inert removal and classification: Sharps (sewing needles, straight pins and hypodermic needles) % > 4mm fraction	% dry weight basis	none detected
Particle size fine for compost used as soil amendment	TMECC 02.02-B Sample sieving for aggregate Size classification	% dry weight basis	Pass 2"-inch sieve 98% min Pass 3/8-inch sieve 95% min
Arsenic		mg/kg (ppm)	EPA 503 pass < 10 OMRI
Cadmium		mg/kg (ppm)	EPA 503 pass < 20 OMRI
Chromium		mg/kg (ppm)	EPA 503 pass < 100
Copper		mg/kg (ppm)	EPA 503 pass <400
Lead		mg/kg (ppm)	EPA 503 pass < 90 OMRI
Mercury		mg/kg (ppm)	EPA 503 pass <4
Nickel		mg/kg (ppm)	EPA 503 pass <80
Selenium		mg/kg (ppm)	EPA 503 pass <5

The compost laboratory report must confirm the following compost parameters: Property	Test Method	Unit of Measurement	Requirement
Zinc		mg/kg (ppm)	EPA 503 pass <2800
Ammonium (N or NH ₄ -N)		ppm or mg/kg dry weight	<450
Sodium (Na)		% dry weight	<0.5
Carbon:Nitrogen Ratio		Carbon : Nitrogen	≤20:1
Bulk Density		lbs/CY dry weight lbs/CF dry weight	>19 and <41 >500 and <1100

Note: TMECC refers to "Test Methods for the Examination of Composting and Compost," published by the United States Department of Agriculture and the United States Compost Council (USCC). (Table modified from the US Composting Council Landscape Architectural Specifications 2009.)

2.5 ORGANIC FERTILIZERS

- A. Use only organic fertilizers and amendments during the project's construction and establishment phases. Acceptable products are those allowed for use in crop production by at least one of the following:
11. OMRI Generic Materials List
 12. CDFA Organic Input Materials Program
 13. U.S. Department of Agriculture's National Organic Program

2.6 MYCORRHIZAL FUNGI

- A. Dry, granular, water soluble inoculant containing at least 5300 spores per pound of vesicular-arbuscular mycorrhizal fungi and 95 million spores per pound of ectomycorrhizal fungi, and a maximum of 5.5 percent inert material.

2.7 IMPORTED PLANTING TOPSOIL

- A. Contractor shall provide imported planting soil where specified in the plans and details. Use topsoil mix that a minimum of 5% and up to 10% organic matter (with 20% or more compost content). Soil portion must be sandy loam as defined by USDA. Submit soil analysis report per section 2.2 A & C.
1. Imported topsoil must be free from deleterious substances such as litter, refuse, toxic waste, stones larger than 1 inch in size, coarse sand, heavy or stiff clay, brush, sticks, grasses, roots, noxious weed seed, weeds, and other substances detrimental to plant, animal, and human health. The Contractor shall designate their proposed import sources in advance and shall provide source samples and soils test of material to the Owner's Representative.
 2. Material shall be free of seeds.

2.8 STOCKPILED EXISTING TOPSOIL

- A. Contractor shall utilize soil from on-site topsoil stockpile see specification section 312000 for topsoil removal, storage and protection information.

2.9 MULCHES

- A. Mulch for non-bioretenion areas may be provided from chipped trees identified for removal on site With approval by the City Representative. If additional mulch is needed see below.
- B. Organic Mulch material shall be locally produced arbor chip mulch from tree and shrub trimming, 100% recycled material, with no color additive. The mulch shall not contain significant amounts of trimmings from pine or cedar unless well aged. The mulch shall not contain trimmings from eucalyptus trees, or any noxious weeds, plants with thorns or spines, or invasive plants. The largest allowable pieces not larger than 3” in any direction. Bark mulch or shredded redwood bark mulch (“Gorilla hair”) shall not be used.
- C. Approved product for additional Mulch and ALL Bioretention Area Mulch:
 1. “Mixed and Aged” from Greenwaste Recycle Yard , Richmond, CA or approved local equivalent.

2.10 PRE-EMERGENT HERBICIDES

- A. Synthetic pre-emergent herbicides that are listed as prohibited in the Organic Materials Review Institute’s (OMRI) Generic Materials List are not allowed on this project.

2.11 WEED BARRIER (SHEET MULCH) CARDBOARD

- A. Cardboard for sheet mulch shall be 100% recycled, B-flute cardboard or approved equal.
- B. Acceptable cardboard suppliers include North Bay Paper, Petaluma, CA 800-734-2772 and Monahan Paper, Oakland, CA 800-835-4670, or approved equal. Sources of recycled cardboard can also be found at www.lawntogarden.org

2.12 INTEGRATED/ORGANIC PEST MANAGEMENT

- A. Integrated Pest Management (IPM) practices shall be used to control pests and diseases in the landscape. Herbicides may not be used as the first and only weed/ invasive plant control method.
 1. Cultural controls and Mechanical or Physical methods will be used as the first choice in weed management and eradication.
 2. Sheet mulching, a layered system of non-synthetic weed barrier overlain by mulch, shall be employed instead of pesticides.
 3. For weed control non-chemical herbicides using Fatty acids, Acetic and Citric acids, or Clove, Citrus, Mint and Thyme oil may be employed by Contractor as a last resort. These may include:
 - a. Fatty acid potassium salts (e.g. Safer’s Superfast Weed and Grass Killer)
 - b. Acetic and citric acids (e.g. Nature’s Glory Weed and Grass Killer RTU)
 - c. Clove, citrus, mint and thyme oil (e.g. Matran II, Burnout, Xpress)

- B. Pesticides that are prohibited by OMRI in its generic materials list are prohibited.

2.13 TREE-STAKING MATERIALS

- A. Trees that settle out of plumb due to inadequate soil compaction either under or adjacent to the root ball shall be excavated and reset. In no case shall trees that have settled out of plumb be pulled upright using guy wires.
- B. Stakes and ties shall be installed immediately upon approval or planting and shall be removed at the end of the first growing season. Any tree that is not stable at the end of this time shall be rejected.
- C. Stakes: Rough-sawn, untreated, sound, new lodgepole pine, free of knots, holes, cross grain, and other defects, 2-by-2-inch nominal by length indicated, pointed at one end.
- D. Ties: black, corded rubber tree ties or ArborTie Flat woven polypropylene material, 3/4" (cm) wide, 900 lbs. (409 kg) break strength. Length as required by tree staking details on the Drawings. Fasten to stake as noted on Drawings.

2.14 PROTECTIVE COVERING FOR SOIL COMPACTION

- A. Wood planks (minimum 3/4-inch plywood) or 6 inches of coarse organic mulch shall be placed on paths in planting areas for construction crews to use when it is not possible to wait until the soil dries before beginning construction. Protective materials should be reused or recycled when they are no longer needed.

PART 3 – EXECUTION

3.1 EXAMINATION

- A. Examine areas to receive plants for compliance with requirements and conditions affecting installation and performance.
 - 1. Verify that no foreign or deleterious material or liquid such as paint, paint washout, concrete slurry, concrete layers or chunks, cement, plaster, oils, gasoline, diesel fuel, paint thinner, turpentine, tar, roofing compound, or acid has been deposited in soil within a planting area. If foreign or deleterious material is found remove the soil and contamination as directed by Owner's Representative and replace with new planting soil.
 - 2. Do not mix or place soils and soil amendments in frozen, wet, rainy, or muddy conditions.
 - 3. Suspend soil spreading, grading, and tilling operations during periods of excessive soil moisture until the moisture content reaches acceptable levels to attain the required results.
 - 4. Uniformly moisten excessively dry soil that is not workable, and which is too dusty.
- B. Proceed with installation only after unsatisfactory conditions have been corrected.

3.2 IRRIGATION AUDIT

- A. Before planting and mulch are installed contractor must hire a third-party auditor to complete an irrigation audit. See Irrigation specifications for additional information.

3.3 PREPARATION

- A. Protect structures, utilities, sidewalks, pavements, and other facilities and turf areas and existing plants from damage caused by planting operations.
- B. Install erosion-control measures as needed to prevent erosion or displacement of soils and discharge of soil-bearing water runoff or airborne dust to adjacent properties and walkway

3.4 PLANTING AREA SOIL PREPARATION (COORDINATE WITH SUB-SURFACE DRIP IRRIGATION)

- A. Remove any noxious or invasive weeds and dispose of them off site.
- B. Planting area soils where soil must be loosened or tilled to alleviate compaction (previously paved areas, noticeably compacted areas and new tree locations):
 - 1. Subsoil, rip, scarify or till soil to less than 200 psi to a total depth of 18 inches below proposed finish grade.
 - 2. Subsoiling shall form a two-directional grid with channels spaced a minimum of 12 inches apart.
 - 3. Do not subsoil, scarify or till within drip line of existing trees to be retained.
 - 4. Do not subsoil, scarify or till over utility installations within 30 inches of the surface, or where trenching or drainage lines are installed.
 - 5. Lightly incorporate organic soil amendments into the top six inches of soil after subsoiling has taken place, using application rates recommended by Landscape Architect.
- C. Planting area soils where no severe compaction:
 - 1. Loosen subgrade of planting areas to a minimum depth of 12 inches. (300 mm). Remove stones larger than in any dimension and sticks, roots, rubbish, and other extraneous matter and legally dispose of them off Owner's property.
- D. Planting areas that will receive imported soil:
 - 1. Before adding imported topsoil, scarify subsoils to less than 200 psi to a depth of 18 inches below final topsoil grade.
 - 2. Do not scarify or till within drip line of existing trees to be retained.
 - 3. Place first lift of three inches of imported topsoil on scarified surface and till into subsoil.
 - 4. Place second lift of three inches or more of imported topsoil on surface to achieve a minimum depth of 18 inches of friable soil.
 - 5. Lightly incorporate organic soil amendments into the top six inches of soil after subsoiling has taken place, using application rates recommended by Owner's Representative.
- E. Planting beds are to be graded smooth and level, 2" below adjacent paving to accommodate sheet mulch.

- F. Verify that all planting beds shall have a minimum depth of twelve inches of uncompacted soil except where tree roots limit the depth. Soil compaction may be measured using a soil cone penetrometer.
 - G. Remove stones larger than 2 inches in any dimension and sticks, roots, rubbish, and other extraneous matter and legally dispose of them off the property.
 - H. Phase the installation of the soil such that equipment does not have to travel over already installed topsoil or planting mixes.
 - I. Provide quality, size, genus, species, and variety of plants indicated, complying with applicable requirements in ANSI Z60.1.
 - J. Lay out trees and large shrubs at locations and at spacing indicated on plans. Stake locations of individual trees and shrubs and outline areas for multiple plantings. Adjust locations when requested and obtain Owner's Representative acceptance of layout before excavating or planting. Make minor adjustments as required.
 - K. Water entire planting area thoroughly. This may be done the day before planting.
- 3.5 ORGANIC SOIL AMENDMENT AND FERTILIZER APPLICATION (COORDINATE WITH SUB-SURFACE DRIP IRRIGATION)
- A. Apply organic soil amendments at rates recommended by Owner's Representative directly to surface of prepared planting area.
 - B. If using planting area preparation method where soil is loosened to alleviate compaction, gently incorporate the soil amendments into the top six inches of soil. Cover with layer of compost. Sheet mulch will be applied directly over compost layer.
- 3.6 EXCAVATION FOR TREES AND SHRUBS
- A. Planting Pits and Trenches:
 - 1. Excavate circular planting pits with sides sloping inward at a 45-degree angle. Excavations with vertical sides are not acceptable. Excavate so that base of planting pit is approximately two times as wide as ball diameter for container-grown stock.
 - 2. Trim perimeter of bottom leaving center area of bottom raised slightly to support root ball and assist in drainage away from center. Do not excavate deeper than depth of the root ball, measured from the root flare to the bottom of the root ball. Do not further disturb base. Ensure that root ball will sit on undisturbed base soil to prevent settling. Planting pit shall be at a depth that will ensure that the root flare will be 5 to 6 inches above adjacent finish grade in all areas that will be sheet mulched. Where sheet mulching will not be employed the root, flare shall be 3 to 4 inches above finish grade. Scarify sides of planting pit smeared or smoothed during excavation. If area under the plant was initially dug too deep, add soil to raise it to the correct level and thoroughly tamp the added soil to prevent settling.
 - 3. Maintain required angles of repose of adjacent materials as shown on the Drawings. Do not excavate subgrades of adjacent paving, structures, hardscapes, or other new or existing improvements.
 - 4. Maintain supervision of excavations during working hours.
 - 5. Keep excavations covered or otherwise protected when unattended by Installer's personnel.

- B. Subsoil and topsoil removed from excavations shall be used for backfilling if suitable.
- C. Obstructions: Notify owner if unexpected rock or obstructions detrimental to trees or shrubs are encountered in excavations.
- D. Detrimental soil conditions: The landscape architect is to be notified, in writing, of soil conditions encountered, including poor drainage or unexpected water seepage, that the contractor considers detrimental to the growth of plant material. When detrimental conditions are observed, planting shall be discontinued until instructions to resolve the conditions are received from the Owner's Representative.

3.7 DRAINAGE TEST AND AUGER HOLES

- A. Requirements: After tree pits are dug and before planting operations, tree pits shall be water tested for drainage. One location per 80 square feet of tree pit shall be tested. In addition, test all tree pits in any area where a test tree pit does not drain within 24 hours, such as in hardpan areas, rocky ground, construction backfill, compacted areas, flat ground, low spots, and the like, to ensure that pits in those areas will drain properly.
- B. Tests: Fill tree pits with water. Check holes after 24 hours to determine if water has drained out. If the water has not drained out, bring this to the attention of the Engineer for remedial course of action. Adjustment of pit size, adjustment of pit location, or addition of auger holes will be required by the Owner's Representative if a drainage problem exists.
- C. Auger Holes: Auger one 6-inch diameter hole through the bottom of each excavated plant hole that does not drain within the specified 24-hour period. Depth of the drill measured from the bottom of the excavation to the bottom of the drill hole shall be 4 feet. Backfill auger holes with 3/4-inch diameter, well-graded drain rock up to bottom of the plant hole.

3.8 TREE AND SHRUB PLANTING (5-GALLON SIZE AND LARGER)

- A. All plants 5-gallon size and larger shall be planted before installation of the Sheet Mulching System.
- B. Before planting, verify that root flare is visible at top of root ball according to ANSI Z60.1. If root flare is not visible, remove soil in a level manner from the root ball to where the top-most root emerges from the trunk. After soil removal to expose the root flare, verify that root ball still meets size requirements.
- C. Apply Mycorrhizal fungi granular inoculant to roots: Sprinkle inoculant directly on damp roots or root balls of all shrubs immediately before planting. 3 lbs. of inoculant will treat at least 400 typical-size transplants. Use 1 tsp/5cc for small trees and shrubs; 1-4 tablespoons for larger trees.
- D. Set container-grown stock plumb and in center of planting pit or trench with root flare of trees 5 to 6 inches above adjacent finish grades and root flare of shrubs 3 to 4 inches above adjacent finish grades in all areas that will be sheet mulched. Set root flares of trees 4 inches and shrubs 3 inches above adjacent finish grades in areas that will not be sheet mulched.
 - 1. Use unamended native soil for backfill if planting in native soil.
 - 2. Use imported soil for backfill if planting in imported soil.
 - 3. Carefully remove root ball from container without damaging root ball or plant.

4. Backfill around root ball in layers, tamping to settle soil and eliminate voids and air pockets. When planting pit is approximately one-half filled, water thoroughly before placing remainder of backfill. Repeat watering until no more water is absorbed.
 5. Continue backfilling process. Water again after placing and tamping final layer of soil.
- E. When planting on slopes, set the plant so the root flare on the uphill side is flush with the surrounding soil on the slope; the edge of the root ball on the downhill side will be above the surrounding soil. Apply enough soil to cover the downhill side of the root ball.
- 3.9 TREE AND SHRUB PRUNING
- A. Prune, thin, and shape trees and shrubs only if approved by Owner's Representative, according to standard professional horticultural and arboricultural practices. Unless otherwise indicated by Owner's Representative, do not cut tree leaders; remove only injured, dying, or dead branches from trees and shrubs; and prune to retain natural character.
- B. Do not apply pruning paint to wounds.
- 3.10 TREE STABILIZATION
- A. If required, install trunk stabilization as follows unless otherwise indicated:
1. Install Tree stakes as shown on drawings; avoid penetrating root balls or root masses.
 2. Support trees with bands of flexible ties as shown on drawings. Allow enough slack to avoid rigid restraint of tree.
- 3.11 SHEET MULCH INSTALLATION (COORDINATE WITH SUB-SURFACE DRIP IRRIGATION)
- A. After the planting area has been thoroughly watered, the organic soil amendments, including compost, have been applied to surface of planting areas, and the 5 gallon and larger plant materials have been planted, the Sheet Mulch shall be installed
- B. Apply a minimum of two layers of 100% recycled B flute cardboard as a bio-degradable weed barrier to the entire planting area, completely covering all existing soil and vegetation.
1. If subsurface drip irrigation is used, apply cardboard to surface after subsurface irrigation system has been installed.
 2. Wet cardboard thoroughly while applying to prevent it from blowing away.
 3. Avoid walking on wet cardboard.
 4. Do not allow any loose soil to remain on top of cardboard.
 5. Edges of the sheets of Cardboard shall overlap a minimum of 8".
 6. Cardboard shall abut directly against edge of pavement, curbs and boulders.
 7. Cardboard shall be applied to the edge of installed plant root balls without covering any part of the top of the root ball / root crown area.
 8. Excess cardboard shall be folded under itself when abutting against hardscape objects or root crown areas, as opposed to being cut, to avoid excessive cardboard scraps. This folding under process is greatly aided when the cardboard is wet.
 9. Keep all cardboard scraps separate from other construction debris for depositing at a local recycling facility.

- C. Apply mulch to top of cardboard:
 - 1. Apply 1" arbor chip mulch on top of the cardboard to protect cardboard during the planting of 1 gallon and smaller pots.
 - 2. Apply 3" additional arbor chip mulch on top of first application of mulch after planting 1 gallon and smaller pots.
 - 3. Where bubblers are used apply [4"] inches arbor chip mulch directly on top of cardboard.
- D. Do not place mulch or compost within 6 inches of trunks or stems.
- E. Where planting areas are adjacent to paving, gradually taper depth of mulch so that top of mulch meets top of paving.

3.12 SMALL SHRUB, GROUND COVER AND PERENNIAL PLANTINGS

- A. Any plants less than 5-gallon size shall be installed after sheet mulching.
- B. Set out and space ground cover and plants smaller than 5-gallon size as indicated on plans in even rows with triangular spacing.
- C. Apply Mycorrhizal fungi granular inoculant to root balls of all plants during planting: sprinkle 1/4 tablespoon of inoculant directly on damp roots or root balls immediately before planting or scatter inoculant in planting holes. 3 lbs. of inoculant will treat at least 400 typical-size transplants. Use 1 tsp/5cc for small trees and shrubs: 1-4 tablespoons for larger trees. Direct contact with roots is critical.
- D. Plant 1-gallon plants through the cardboard mulch, pushing extra soil under the cardboard layer. Take care not to allow any soil to remain on top of cardboard or mulch.
- E. Plant 4" and smaller plants into the mulch on top of the cardboard without cutting through the cardboard. Backfill around plants with several handfuls of compost on top of cardboard and under mulch.
- F. Use native soil for backfill for larger plants.
- G. Do not leave excess soil on top of sheet mulch. Push excess soil under cardboard.
- H. Work soil around roots to eliminate air pockets and leave a slight saucer indentation around plants to hold water.
- I. Water thoroughly after planting, taking care not to cover plant crowns with wet soil.
- J. Keep mulch 6" min. from root crown.
- K. Protect plants from hot sun and wind; remove protection if plants show evidence of recovery from transplanting shock.

3.13 PLANT MAINTENANCE

- A. Maintain plantings by pruning, cultivating, watering, weeding, fertilizing with organic fertilizers as need is shown by soil testing, mulching, restoring planting saucers, adjusting

and repairing tree-stabilization devices, resetting to proper grades or vertical position, and performing other operations as required to establish healthy, viable plantings.

- B. Fill in as necessary soil subsidence that may occur because of settling or other processes. Replace mulch materials damaged or lost in areas of subsidence.
- C. Mulch shall be replenished as needed to maintain a depth of 3". Additional cardboard under mulch or thicker mulch may need to be used for persistent weeds.
- D. Apply treatments as required to keep plant materials, planted areas, and soils free of pests and pathogens or disease. Use integrated pest management practices. Treatments include physical controls such as hosing off foliage, mechanical controls such as traps, and biological control agents.

3.14 FERTILIZERS AND PESTICIDES

- A. No chemical fertilizers, herbicides, pesticides or other disease control chemicals to be used. Only materials approved for organic crop production by the Organic Materials Review Institute (OMRI) may be used, and only with approval from Owner's Representative. See www.omri.org. Integrated Pest Management (IPM) practices shall be used.

3.15 CLEANUP AND PROTECTION

- A. During planting, keep adjacent paving and construction clean and work area in an orderly condition.
- B. Protect plants from damage due to landscape operations and operations of other contractors and trades. Maintain protection during installation and maintenance periods. Treat, repair, or replace damaged plantings.
- C. After installation and before Substantial Completion, remove nursery tags, nursery stakes, tie tape, labels, wire, burlap, and other debris from plant material, planting areas, and Project site.
- D. Any shrubs or trees to be removed shall be chipped on site and used for mulch. All resulting mulch shall meet requirements of this specification.
- E. Weeding, Cultivating, and Cleanup: Planting areas shall always be kept neat and free from debris. All areas shall be weed free at the end of the plant establishment and maintenance period.

3.16 DISPOSAL

- A. Recycle all waste per these specifications. Reuse or return unused items such as pallets, flats and pots. All plant debris (green waste) shall be separated from other refuse and taken to a facility where it will be recycled i.e., to produce compost or mulch.

END OF SECTION

SECTION 32 94 50
LANDSCAPE STONE

PART 1 - GENERAL

1.1 SUMMARY

- A. Section includes the following applications of landscape stone:
 - 1. Boulders: Rounded Boulders, Flat-Topped Boulders & Transfer Boulders
 - 2. Stone pavers
 - 3. Stepping Stones
- B. Related Documents and Sections:
 - 1. City of Cupertino Project Manual
 - 2. Section 32 11 00 – Base Courses
 - 3. Section 32 13 00 – Rigid Paving

1.2 PRICE AND PAYMENT PROCEDURES

- A. Refer to City of Cupertino Project Manual

1.2 SUBMITTALS

- B. Product Data: For each type of product indicated.
 - 1. For stone varieties proposed for use on Project, include photographs with a reference scale showing the size of the stones.
 - 2. For each color of mortar required.
- C. Samples:
 - 1. For each stone type indicated, include at least two samples in each set for each type of stone, exhibiting extremes of the full range of color and other visual characteristics expected in completed Work. Samples will establish the standard by which stone provided will be judged.

1.3 QUALITY ASSURANCE

- A. Installer Qualifications: A qualified installer who employs experienced stonemasons and stone fitters.
- B. Source Limitations for Stone: Obtain each variety of stone, from one quarry or supplier with resources to provide materials of consistent quality in appearance and physical properties.

- C. Source Limitations for Mortar Materials: Obtain mortar ingredients of a uniform quality, including color for exposed masonry, from single manufacturer for each cementitious component and from single source or producer for each aggregate.
- D. Mockup: Where boulders are set in concrete curbs or walls, build mockup to demonstrate aesthetic effects and set quality standards for materials and execution.
 - 1. Protect accepted mockups from the elements with weather-resistant membrane.
 - 2. Approval of mockups is for color, texture, and blending of stone; relationship of mortar colors to stone colors; tooling of joints; and aesthetic qualities of workmanship.
 - 3. Approval of mockups is also for other material and construction qualities the Owner's Representative specifically approves in writing.
 - 4. Approval of mockups does not constitute approval of deviations from the Contract Documents contained in mockups unless Owner's Representative specifically approves such deviations in writing.
 - 5. Approved mockups may become part of the completed Work if undisturbed at time of Substantial Completion.

PART 2 - PRODUCTS

2.1 ROUNDED BOULDERS, FLAT-TOPPED BOULDERS AND TRANSFER BOULDERS

- A. Criteria: Boulders shall be uniform, medium grained, smooth, stones without sharp edges, fractures or holes. Stones shall be tagged in the stone supply yard for review and approval by the Owner's Representative.
- B. Stone Type: "Sierra Granite" boulders from W.Johnson Ornamental and Building Stone, 4132 Santa Rosa Ave, Santa Rosa, CA 95407, USA, (707) 584-7480; or "Amador Granite" boulders from Lyngso, www.lyngsogarden.com., 345 Shoreway Road, San Carlos, CA 94070, 650-364-1730; or approved equal. Substitutions must meet aesthetic considerations of color (primarily gray tones) and required dimensions per drawings.
- C. Boulder Size: Overall dimensions as shown on Drawings.
- D. Transfer Boulder Size and Configuration: Final dimensions and placement must meet ADA transfer requirements as shown on drawings.

2.2 STONE PAVERS & STEPPING STONES

- A. Criteria: Solid, non-crumbling rock, free of sharp corners and edges, open cracks or holes with smooth river washed or weathered edge
- B. Stone Type: "Bouquet Canyon" irregular flagstone from Lyngso, www.lyngsogarden.com., 345 Shoreway Road, San Carlos, CA 94070, 650-364-1730, or approved equal.
- C. Size: 12" to 24" irregular shaped flat stones, minimum 2" thick.

2.3 MORTAR MATERIALS

- A. Portland Cement: ASTM C 150, Type I or II, except Type III may be used for cold-weather construction. Provide natural color or white cement as required to produce mortar color indicated.
 - 1. Low-Alkali Cement: Not more than 0.60 percent total alkali when tested according to ASTM C 114.
- B. Hydrated Lime: ASTM C 207, Type S.
- C. Masonry Cement: ASTM C 91.
- D. Mortar Pigments: Natural and synthetic iron oxides and chromium oxides, compounded for use in mortar mixes. Use only pigments with a record of satisfactory performance in stone masonry mortar.
 - 1. Products: Subject to compliance with requirements, available products that may be incorporated into the Work include, but are not limited to, the following:
 - a. Davis Colors; True Tone Mortar Colors.
 - b. Lanxess Corporation; Bayferrox Iron Oxide Pigments.
 - c. Solomon Colors; SGS Mortar Colors.
- E. Colored Cement Product: Packaged blend made from portland cement and lime or masonry cement and mortar pigments, all complying with specified requirements, and containing no other ingredients.
 - 1. Formulate blend as required to produce color indicated or, if not indicated, as selected from manufacturer's standard colors.
 - 2. Products: Subject to compliance with requirements, available products that may be incorporated into the Work include, but are not limited to, the following:
 - a. Colored Portland Cement-Lime Mix:
 - 1) Holcim (US) Inc.; Rainbow Mortamix Custom Color Cement/Lime.
 - 2) Lafarge North America; Eaglebond.
 - 3) Lehigh Cement Company; Lehigh Custom Color Portland/Lime Cement.
 - b. Colored Masonry Cement:
 - 1) Essroc, Italcementi Group; Brixment-in-Color.
 - 2) Holcim (US) Inc.; Rainbow Mortamix Custom Color Masonry Cement.
 - 3) Lafarge North America; Florida Custom Color Masonry or Magnolia Masonry Cement.
 - 4) Lehigh Cement Company; Lehigh Custom Color Masonry Cement.
- F. Aggregate: ASTM C 144 and as follows:
 - 1. For pointing mortar, use aggregate graded with 100 percent passing No. 16 sieve.
 - 2. White Aggregates: Natural white sand or ground white stone.

3. Colored Aggregates: Natural-colored sand or ground marble, granite, or other sound stone of color necessary to produce required mortar color.
- G. Latex Additive: Manufacturer's standard water emulsion, serving as replacement for part or all of gaging water, of type specifically recommended by latex-additive manufacturer for use with field-mixed portland cement mortar bed, and not containing a retarder.
1. Manufacturers: Subject to compliance with requirements, available manufacturers offering products that may be incorporated into the Work include, but are not limited to, the following:
 - a. Boiardi Products Corporation.
 - b. Bonsal.
 - c. Bostik Findley Inc.
 - d. C-Cure.
 - e. Custom Building Products.
 - f. DAP Inc.
 - g. Laticrete International, Inc.
 - h. MAPEI Corp.
 - i. Summitville Tiles, Inc.
 - j. TEC Specialty Construction Brands; H. B. Fuller Company.
- H. Water: Potable.

PART 3 - EXECUTION

3.1 SETTING OF STONE MASONRY, GENERAL

- A. Perform necessary field cutting and trimming as stone is set.
 1. Use power saws to cut stone that is fabricated with saw-cut surfaces.
 2. Use hammer and chisel to split stone that is fabricated with split surfaces.
- B. Sort stone before it is placed in wall to remove stone that does not comply with requirements relating to aesthetic effects, physical properties, or fabrication, or that is otherwise unsuitable for intended use.
- C. Arrange stones in range ashlar pattern with course heights as indicated, **random** lengths, and uniform joint widths, with offset between vertical joints as indicated.
- D. Arrange stones with color and size variations uniformly dispersed for an evenly blended appearance.
- E. Maintain uniform joint widths except for variations due to different stone sizes and where minor variations are required to maintain bond alignment if any. Lay walls with joints not less than **1/4 inch** at narrowest points or more than **1/2 inch** at widest points.
- F. Place weep holes and vents in joints where moisture may accumulate, including at base of cavity walls, above shelf angles, and at flashing.
 1. Use round plastic tubing to form weep holes.

3.2 CONSTRUCTION TOLERANCES

- A. Variation from Plumb: For vertical lines and surfaces, do not exceed 1/4 inch in 10 feet, 3/8 inch in 20 feet, or 1/2 inch in 40 feet or more. For external corners, expansion joints, control joints, and other conspicuous lines, do not exceed 1/4 inch in 20 feet or 1/2 inch in 20 feet or more.
- B. Variation from Level: For **bed joints and** lines of exposed horizontal grooves, and other conspicuous lines, do not exceed 1/2 inch in 20 feet or more.
- C. Variation of Linear Line: For position shown in plan, do not exceed 3/4 inch in 20 feet or more.

3.3 POINTING

- A. Prepare stone-joint surfaces for pointing with mortar by removing dust and mortar particles. Where setting mortar was removed to depths greater than surrounding areas, apply pointing mortar in layers not more than 3/8 inch deep until a uniform depth is formed.
- B. Point stone joints by placing and compacting pointing mortar in layers not more than 3/8 inch deep. Compact each layer thoroughly and allow to become thumbprint hard before applying next layer.
- C. Tool joints, when pointing mortar is thumbprint hard, with a smooth jointing tool to produce the following joint profile:
 - 1. Joint Profile: Concave.

3.4 ADJUSTING AND CLEANING

- A. In-Progress Cleaning: Clean stone masonry as work progresses. Remove mortar fins and smears before tooling joints.
- B. Final Cleaning: After mortar is thoroughly set and cured, clean stone masonry as follows:
 - 1. Remove large mortar particles by hand with wooden paddles and nonmetallic scrape hoes or chisels.
 - 2. Test cleaning methods on mockup; leave one-half of panel uncleaned for comparison purposes.
 - 3. Protect adjacent stone and non-masonry surfaces from contact with cleaner by covering them with liquid strippable masking agent, polyethylene film, or waterproof masking tape.
 - 4. Wet wall surfaces with water before applying cleaner; remove cleaner promptly by rinsing thoroughly with clear water.
 - 5. Clean stone masonry by bucket and brush hand-cleaning method described in BIA Technical Note No. 20 Revised II, using job-mixed detergent solution.

6. Clean stone masonry with proprietary acidic cleaner applied according to manufacturer's written instructions.
7. Clean limestone masonry to comply with recommendations in ILI's "Indiana Limestone Handbook."

3.5 STEPPING STONE INSTALLATION

- A. Stepping stones shall be set in concrete setting bed, per drawings, with top surface approximately flush with surrounding finish grade. Review with City Representative depth, angle, etc., prior to final installation.

3.6 EXCESS MATERIALS AND WASTE

- A. Disposal as Fill Material: Dispose of clean masonry waste, including mortar and excess or soil-contaminated sand, by crushing and mixing with fill material as fill is placed.
 1. Do not dispose of masonry waste as fill within 18 inches of finished grade.

END OF SECTION

SECTION 334000

STORM DRAINAGE UTILITIES

PART 1 - GENERAL

1.1 SUMMARY

- A. Section Includes: All labor, materials, equipment, tools, accessories, transportation, and services as required for the installation and construction of storm subdrainage utilities, storm drainage structures, and connections to rip-rap outfalls as shown on the plans.
- B. Related Requirements
 - 1. Section 312200, Grading
 - 2. Section 312100, Utility Trenching and Backfill

1.2 PRICE AND PAYMENT PROCEDURES

- A. Refer to City of Cupertino Project Manual.

1.3 REFERENCES

- A. Reference Standards
 - 1. City of Cupertino General Conditions
 - 2. Caltrans Standard Specifications, Section 62, Stormwater Treatment
 - 3. Caltrans Standard Specifications, Section 64, Plastic Pipe
 - 4. Caltrans Standard Specifications, Section 65, Concrete Pipe
 - 5. Caltrans Standard Specifications, Section 68, Subsurface Drains
 - 6. Caltrans Standard Specifications, Section 70, Miscellaneous Drainage Facilities
 - 7. Caltrans Standard Specifications, Section 71, Existing Drainage Facilities

1.4 SUBMITTALS

- A. Product Data: Submit for each type of product specified.
- B. Record Drawings: Contractor shall maintain a daily log of on-site installation and changes from the Contract Documents on a set of prints provided to Contractor by City for record purposes. A clearly legible and detailed print of said log, acceptable to the City's Representative, shall be submitted to the City prior to final payment.

1.5 QUALITY ASSURANCE

- A. Reviews: Twenty four (24) hours prior to placement of backfill above the pipe bedding, the City's Representative shall be notified by the Contractor and shall be allowed such reasonable time to inspect placement of the pipe and pipe bedding.

1.6 DELIVERY, STORAGE, AND HANDLING

- A. Materials: Attention is directed to Section 6, Control of Materials of the Caltrans Standard Specifications and these Special Provisions. All materials required to complete the work under this contract shall be furnished by the Contractor.
- B. Handling: Reinforced concrete pipe, pre-cast concrete manhole sections, inlet frames and grating, and fittings must be handled carefully at all times. Only suitable and proper equipment and appliances shall be used for the safe loading, hauling, unloading, handling, and placing of materials. Material that is checked, spalled or damaged shall not be installed and must be permanently removed from the job site.

1.7 WARRANTY

- A. Final Guarantee: Contractor shall provide guarantee according to City of Cupertino General Conditions.

PART 2 - PRODUCTS

2.1 PLAY AREA DRAINAGE

- A. Description: SDR 26 PolyVinyl Chloride (PVC) plastic pipe shall be as specified in Caltrans Standard Specifications, 64, Plastic Pipe.
 - 1. perforated/non-perforated
 - 2. corrugated/rigid
 - 3. size as noted on drawings

2.2 SITE DRAINAGE, ON SITE TRAFFIC AREAS

- A. Description: SDR 26 PVC plastic pipe shall be as specified in Caltrans Standard Specifications, 64, Plastic Pipe.

2.3 SITE DRAINAGE, NON-TRAFFIC LANDSCAPE AREAS

- A. Description: SDR 26 or 35 PVC plastic pipe shall be as specified in Caltrans Standard Specifications, 64, Plastic Pipe.
 - 1. Non-perforated.
 - 2. Rigid plastic pipe.
 - 3. Size as noted on drawings.

2.4 DRAINAGE WITHIN STREET RIGHT-OF-WAY

- A. Description: Reinforced concrete pipe shall be as specified in Caltrans Standard Specifications, Section 65, Concrete Pipe.
 - 1. Minimum twelve inches (12") diameter.

2.5 FRAMES AND GRATES

- A. Description: As indicated on the plans.

2.6 STORM DRAINAGE STRUCTURES STENCIL

- A. Contractor shall provide Stencil according to City of Cupertino General Conditions.

2.7 OTHER MATERIALS

- A. Drain Rock: 3/8 inch pea gravel.
- B. Catch Basin: Christy V-64 or approved equal, with appropriate extensions to extend 2 inches below invert elevations as shown on drawings.
- C. Area Drains: Christy V-64 or approved equal, with appropriate extensions to extend 2 inches below invert elevations as shown on drawings.
- D. Filter Fabric: Light weight polyester engineering fabric, LandMaster Polyspun "XL" or approved equal, as supplied by Horizon Irrigation, 4060 Campbell Avenue, Menlo Park, CA 94025, (650) 323-51561.
- E. Rock for Rock Outfall: Smooth rocks, one foot to two feet and six inches (1'0"-2'6") in diameter as supplied by Langley Hill Quarry, or approved equal, 19500 Skyline Boulevard, Woodside, CA (650) 851-0179.
- F. Geotextile Fabric: Mirafi 140N non-woven geotextile fabric or approved equal. As available from United Green Mark, 1675 Nichols Drive, Rocklin, CA 95765, Larry Hood, (916) 947-5128.

2.8 ACCESSORIES

- A. Contractor shall provide all necessary fittings and coupling systems for both systems.
- B. Joints and joint material for concrete pipe shall conform Caltrans Standard Specifications, Section 65, Concrete Pipe.

PART 3 - EXECUTION

3.1 PREPARATION

- A. Protection of In-Place Conditions
 1. Surrounding areas, surfaces and appurtenances already in place shall be protected during installation of storm drainage utilities.

3.2 INSTALLATION

- A. Excavation, pipe laying, joints, and backfill shall conform to the Caltrans Standard Specifications.
- B. Backfill shall conform to Section 312100, Utility Trenching and Backfill, except that ninety percent (95%) relative compaction on the top six inches (6") of trench shall be required only where surface improvements other than plantings are made under this contract.
- C. Lines shall be flushed in accordance with the Caltrans Standard Specifications.
- D. Inlet boxes shall be constructed in accordance with the plans.
- E. The Contractor shall stencil all hooded storm drain inlets and catch basins with "No Dumping-Flows to Bay" stencil. The Contractor shall locate the stencil on the face of the curb adjacent to the catch basin hood. The left side is preferred.

3.3 ADJUSTING

- A. Frames, Grates and Covers
 - 1. Frames, grates, and covers of all surface structures (manholes, clean outs, etc.) shall be adjusted to proposed finish grade. Grade rings shall be supplied and installed as required.
 - 2. Frames of new or adjusted surface structures shall be supported by concrete with minimum dimensions as follows: Six inches (6") wide by ten inches (10") deep.
- B. Structures within Paved Areas
 - 1. A structure located in an area resurfaced with asphalt concrete shall not be constructed to final grade until the adjacent pavement or surfacing has been compacted.
 - 2. The Contractor shall be responsible for referencing structures prior to paving and locating them after paving operations are completed.
 - 3. After asphalt concrete resurfacing is completed, the asphalt shall be cut out six inches (6") wider than the frames of all surface structures. Each frame shall then be added to the concrete to produce a dark finished surface which matches the surrounding asphalt concrete surface.

END OF SECTION

SECTION 33 46 00

BIORETENTION SUBDRAINAGE

PART 1 - GENERAL

1.1 SECTION INCLUDES

- A. Subdrains in trenches and subdrains
- B. Bioretention and biofiltration areas for storm water treatment

1.2 RELATED SECTIONS

- A. Section 312100, Utility Trenching and Backfill
- B. Section 334000, Storm Drainage Utilities

1.3 RELATED DOCUMENTS

- A. Geotechnical Report: Geotechnical Evaluation, Jollyman Park All-Inclusive Playground, Ninyo & Moore Geotechnical & Environmental Sciences Consultants, February 18th 2022.
- B. AASHTO
 - 1. M288: Standard Specification for Geotextiles Used for Subsurface Drainage Purposes
- C. ASTM
 - 1. C1173: Standard Specification for Flexible Transition Couplings for Underground Piping Systems
 - 2. D448: Standard Classification for Sizes of Aggregate for Road and Bridge Construction
 - 3. D1621: Standard Test Method for Compressive Properties of Rigid Cellular Plastics
 - 4. D1785: Standard Specification for Poly (Vinyl Chloride) (PVC) Plastic Pipe, Schedules 40, 80, and 120
 - 5. D2321: Standard Practice for Underground Installation of Thermoplastic Pipe for Sewers and Other Gravity-Flow Applications
 - 6. D2564: Standard Specification for Solvent Cements for Poly (Vinyl Chloride) (PVC) Plastic Piping Systems
 - 7. D2729: Standard Specification for Poly (Vinyl Chloride) (PVC) Sewer Pipe and Fittings
 - 8. D3034: Standard Specification for Type PSM Poly (Vinyl Chloride) (PVC) Sewer Pipe and Fittings
 - 9. D4716: Standard Test Method for Determining the (In-Plane) Flow Rate per Unit Width and Hydraulic Transmissivity of a Geosynthetic Using a Constant Head
 - 10. F477: Standard Specification for Elastomeric Seals (Gaskets) for Joining Plastic Pipe
 - 11. F656: Standard Specification for Primers for Use in Solvent Cement Joints of Poly(Vinyl Chloride) (PVC) Plastic Pipe and Fittings
 - 12. F1336: Standard Specification for Poly(Vinyl Chloride) (PVC) Gasket Sewer Fittings

- D. Caltrans Standard Specifications, 2022
 - 1. Section 68-Subsurface Drains
 - 2. Section 96-Geosynthetics
 - 3. Section 62-Stormwater Treatment
 - 4. Section 64-Plastic Pipe

1.4 DEFINITIONS

- A. AASHTO: American Association of State Highway and Transportation Officials
- B. ASTM: American Society for Testing and Materials
- C. PVC: Polyvinyl Chloride

1.5 SUBMITTALS

- A. Follow submittal procedure in accordance with Section 011000, Supplemental General Requirements.
- B. Product data for the following:
 - 1. Perforated pipe and fittings
 - 2. Solid pipe and fittings
 - 3. Prefabricated composite drainage panels
 - 4. Geotextile fabrics
 - 5. Cleanout plugs or caps
 - 6. Precast clean out boxes and box covers
 - 7. Drainage bubblers
 - 8. Biofiltration soil material
- C. Samples:
 - 1. Drainage Fill

1.6 DELIVERY, STORAGE AND HANDLING

- A. Do not store plastic structures, pipe, and fittings in direct sunlight.
- B. Protect pipe, pipe-fittings, and seals from dirt and damage.
- C. Protect permeable material from contamination by other materials.

PART 2 - PRODUCTS

2.1 PERFORATED WALL AND SOLID WALL PIPE

- A. PVC pipe and Fittings Smaller than 4-inch:
 - 1. Pipe: ASTM D1785, Schedule 40. Solvent cement joints
 - 2. Solvent Cement: ASTM D2564. Include primer according to ASTM F656.
 - 3. Perforation Size, Location, and Spacing: ASTM D2729
- B. PVC Pipe and Fittings 4-inch through 15-inch:

1. Pipe: ASTM D3034, SDR 26. Bell and spigot joints
2. Perforation Size, Location, and Spacing: ASTM D2729
3. Fittings: ASTM F1336
4. Joint Gasket: Elastomeric seal, ASTM F477

2.2 SPECIAL PIPE COUPLINGS

- A. Description: ASTM C1173. Rubber or elastomeric sleeve and stainless steel band assembly fabricated to match outside diameters of pipes to be joined.

2.3 CLEANOUTS

- A. Piping: Same as subdrain pipe without perforations.
- B. Top Plug or Cap: Same material as piping if possible. Plug or cap to be secure but removable, threaded or non-threaded.
 1. Size box to provide access and allow easy removal and reinstallation of plug or cap.
 2. Types:
 - a. Non-Traffic Areas: Portland cement concrete box and box cover, light duty.
 - b. Traffic Areas: Portland cement concrete box and box cover or steel or cast iron cover, heavy duty, both box and cover to be rated for AASHTO H20 loading.
- C. Cover Markings: "STORM DRAIN" unless otherwise specified.
 1. Available Manufacturers: Subject to compliance with requirements, manufacturers offering products that may be incorporated into the Project include, but are not limited to, the following:
 - a. Associated Concrete Products, Inc.,
 - b. Brooks Products Inc.,
 - c. Christy Concrete Products, Inc., or approved equal

2.4 BIORETENTION OR BIOFILTRATION TREATMENT SOIL

- A. Soil specification shall meet requirements of local agency having authority or sustainability requirements for projects achieving environmental goals.
 1. For projects located within the jurisdiction of the Municipal Regional Stormwater Permit (MRP), treatment soil shall conform to requirements in Appendix L of the MRP. Contractor shall provide submittal information verifying conformance to MRP standard.

2.5 DRAINAGE FILL MATERIAL

- A. Permeable Material: Conform to Section 68-2.02F(3) of Caltrans Standard Specifications, Class 2.
- B. Washed, evenly graded mixture of crushed stone, or crushed or uncrushed gravel, ASTM D 448, coarse aggregate, Sieve No. 57, with 100 percent passing 1-1/2-inch sieve and not more than 5 percent passing No. 8 sieve

2.6 GEOSYNTHETICS

- A. When required, use filter fabric for encasing permeable material around subdrains.
 - 1. Caltrans Filter Fabric: Section 96-1.02B of Caltrans Standard Specifications,
 - 2. Mirafi 140N (by Tencate Geosynthetics/Mirafi Inc.), or approved equal.

PART 3 - EXECUTION

3.1 EXAMINATION

- A. Examine surfaces and areas for suitable conditions where subdrainage systems are to be installed.
- B. Install only after unsatisfactory conditions have been corrected.

3.2 PIPING APPLICATIONS

- A. Refer to Plans for location, size, and material designation for individual subdrains.

3.3 INSTALLATION of perforated portions of subdrains

- A. Excavation: Section 6 of ASTM D2321 and as indicated.
- B. Subdrain Bedding: Place supporting layer of drainage fill over compacted subgrade to compacted depth indicated. If drainage fill requires encasement in filter fabric, lay filter fabric in trench and overlap trench sides before installing drainage fill.
- C. Piping Installation: Install pipe in accordance with Section 7 of ASTM D2321. Install piping beginning at low point of system, true to grades and alignment indicated, with unbroken continuity of invert. Excavate recesses for bottoms of bell ends of pipe. Lay pipe with bells facing upslope and with spigot end centered fully into adjacent bell. Bed piping with full pipe bearing in drainage fill material. Lay perforated pipe with perforations down. Install gaskets, seals, sleeves, and couplings in accordance with manufacturers written instructions. Use increasers, reducers, and couplings made for different sizes of materials of pipes and fittings being connected. Reduction of pipe size in direction of flow is prohibited.
- D. Initial Subdrain Backfill: After installing drainage piping, add drainage fill up to top of pipe to perform tests.
- E. Testing Subdrain: After installing drainage fill to top of pipe, test drain piping with water to ensure free flow before backfilling with drainage fill. Remove obstructions, replace damaged components, and repeat test until results are satisfactory.
- F. Subsequent Subdrain Backfill: After satisfactory testing, cover piping with drainage fill to width and height indicated. Place drainage fill in layers not exceeding 3 inches in loose depth; compact each layer placed. If filter fabric is required complete the filter fabric encasement by bringing fabric to top and closing the encasement.

- G. Fill to Grade: Place native fill material over compacted drainage fill to thickness indicated. Place material in loose-depth layers not exceeding 6 inches. Thoroughly compact each layer. Fill to finish elevations.

3.4 INSTALLATION OF NON-PERFORATED PORTIONS OF SUBDRAINS

- A. Conform to Sections 312333, Utility Trenching and Backfill and 334100, Storm Drainage Utilities.

3.5 INSTALLATION OF BIORETENTION OR BIOFILTRATION TREATMENT AREAS

- A. The Contractor shall excavate treatment areas to the elevations and dimensions specified on the plans. Level surface of area of top of treatment soil shown on the plans shall govern actual length and width dimensions if shown on the plans. In-situ soils shall not be further compacted.
- B. After initial site grading, the Contractor shall provide temporary protection from curb cuts and other potential inflow entrances so that runoff drainage does not enter the rain gardens during construction and installation.
 - 1. Treatment areas may be used as sediment settling facilities during mass excavation and commensurate construction activities.
- C. Excavated soils shall be placed with stockpiled fill and properly disposed and stabilized by the Contractor.
- D. Subdrain installation:
 - 1. Subdrain shall be installed as indicated on the plans at an elevation within the drain rock layer shown on the construction details and connected to the overflow or outfall structure at the invert elevation shown on the plans.
 - 2. For connections of the perforated drain pipes to storm drainage structures, appropriately sized holes shall be cut in the structures at the correct invert elevation specified by the Project Designer or authorized representative. The connections shall be sealed sediment-tight and secured in place with mortar or other approved joint sealant compatible with subdrain pipe materials.
 - 3. Drain rock layer shall be approved Class II Permeable Material. Crushed rock or aggregate base cannot be used within the treatment area, in, around or under the drain rock layer.
 - 4. Care shall be exercised to prevent natural or fill soils from intermixing with the drain rock surrounding the underdrain. All contaminated drain rock shall be removed and replaced with uncontaminated Class II permeable material.
 - 5. Attach subdrain piping to overflow structure.
 - 6. Install cleanouts at the ends of the subdrains. Install screw-on end caps set flush with the finished top of treatment soil.
- E. Overflow drain structure:
 - 1. Install overflow structure at the elevation and location specified on the plans. Attach subdrain piping to overflow structure. Attach solid pipe from overflow structure outfall storm drain system at elevation and slope indicated on the plans.
 - 2. Rim elevation of overflow structure must be set above the elevation of the top of treatment soil by the amount indicated on the plans, typically 6

inches. Contractor shall verify that the rim elevation of the overflow structure is also a minimum of 2 inches below the lowest elevation of the treatment area perimeter so that storm flows will reach the overflow rim before the top of the treatment area perimeter.

3. The overflow structure shall have an open bottom filled with drain rock if indicated on the plans. This should be installed where the overflow structure has a sump condition (subdrains lower than the outfall invert elevation). The overflow structure shall be installed such that the bottom of the structure is set a minimum of 6-inches below the undisturbed bottom of the treatment area. Drain rock in the overflow sump shall be installed up to the invert of the lowest pipe connected to the structure.

F. Filter media soil backfill

1. Filter soil of the approved specification shall be installed to the elevation indicated on the plans. Care should be taken to ensure that the soil is not compacted and that no equipment is driven on the backfill. Walking on the backfill should be limited to what is absolutely necessary.

- G. Planting soil, plantings, and mulch shall be installed per the plans. Non-floating bark / mulch shall be used, if indicated, to prevent removal of material and clogging of the overflow.

- H. Testing of the treatment area should be conducted once the filter media is installed and all storm drain piping is connected. The area should allow an infiltration rate well above 5 inches/ hour to ensure that the treatment area will continue to function at 5 inches/ hour over the lifetime of the treatment area.

3.6 Prefabricated Composite Drainage Panels

- A. Coordinate placement with other drainage materials.
- B. Install prefabricated drainage panels in accordance with manufacturer's instructions.
- C. Place perforated drainage pipe at base of footing and attach to composite drainage panels in accordance with the manufacturer's instructions.

3.7 JOINING PIPE

- A. Join PVC pipe and fittings with elastomeric seals according to ASTM D2321 or solvent cement.
- B. Special pipe couplings: Join piping made of different materials and dimensions with special couplings made for this application. Use couplings that are compatible with and that fit both pipe materials and dimensions.

3.8 CLEANOUT INSTALLATION

- A. Cleanout piping to be the same size as the subdrain piping to which it is attached.

- B. Install cleanouts from subdrainage piping to grade. Locate cleanouts at beginning of piping run, at changes in direction, and other locations indicated.
- C. Do not allow cleanout box to bear on cleanout riser.

3.9 CLEANING

- A. Clear interior of installed piping and structures of dirt and other superfluous material as work progresses. Maintain swab or drag in piping and pull past each joint as it is completed. Place plugs in ends of uncompleted pipe at end of each day or when work stops.

END OF SECTION